

規格承認書

PECIFICATION FOR APPROVAL

客 戶
CUSTOMER : 立創
項 目
ITEM : 塑壳内磁方形喇叭
型 號
TYPE : GSPK272065TN-8R1W
描述
DESCRIPTION : L27 x W20 x H6.5 MM 8Ω 1W S.P.L: 77 dB+/- 3dB
客戶料號
CUSTOMER NO. :
規 格 書 號
SPECIFICATION NO.:
版 本
EDITION NO. : V1.1
日 期
DATE : 2020-7-9

客戶承認

CUSTOMER CONFIRM AND SIGN

檢 查 TESTED BY	審 核 CHECKED BY	承 認 APPROVED BY

東莞市贏海電子有限公司

DONGUAN INGHAI ELECTRONICS CO.,LTD

製 作 ISSUED BY	審 查 CHECKED BY	確 認 APPROVED BY
周明	刘承成	

地址：廣東省東莞市虎門鎮懷德社區雅瑤工業區
電話 / TEL: 0769-83060958 傳真 / FAX: 0769-81608993
網址: [HTTP://WWW.INGHAI.COM](http://www.inghai.com)

DONGGUAN INGHAI ELECTRONICS CO.,LTD

1.适用范围 Applicable Scope:

this kind of specification is applied in multi-media

1.1 类型 Type	Permanent-magnet dynamic loudspeaker
1.2 寸法 Dimensions	outer diameter 20*27 mm High 6.5 mm
1.3 输入功率 Input power	Rated power: 1.0 W;Maximum power: 1.5 W

2.机械特性 Mechanical Speciality

2.1 外观尺寸 Appearance Dimensions	See Product drawing
2.2 磁铁 Magnet	Φ 13.8*2.5 mm
2.3 重量 Weight	5 / g \pm 10%

3.电气特性 Electrical Speciality

3.1 标称阻抗 Nominal Impedance	8 Ω \pm 15% At 750 Hz test
3.2 直流阻抗 DC Impedance	8.0 Ω \pm 10%
3.3 最低共振周波数 Lowest Resonance Frequency	800 Hz \pm 20%
3.4 灵敏度 Output Sound Pressure Level	77 \pm 3 dB / 1 W/800mV 0.1 M Average at 1000. 1200. 1500. 2000 HZ
3.5 有效频宽 Effective Frequency Band	F0 \sim 20 KHz Average SPL-10 dB
3.6 失真率 Distortion	5% Maxium at 1000 HZ 0.1 W/0.1M
3.7 纯音检测 Pure tone Test	Must be normal at sine wave 2.83 V, at 200 Hz \sim 3 K Hz, .
3.8 极性 Polarity	When a positive current is supplied from the speaker the terminal marked (+) , and a negative to the other terminal the diaphragm must move toward the front.

4. 信赖性 Reliable Test

<p>4.1 连续负荷 Load Test</p>	<p>Use Sunlilab-Model-8121c white noise signal 1.0 W 48 Hour, After the test should be able to meet the requirements of section 3.7, There shall be no distinct deformation in appearance.</p>
<p>4.2 高温保存 High-temperature preservation</p>	<p>Temperature of 60 ± 2 °C, humidity of 20 ~ 30% for 96 hour, at room temperature the shelving of 1 hour, the test no abnormal adverse</p>
<p>4.3 低温保存 Low-temperature preservation</p>	<p>Temperature of -25 ± 2 °C, for 96 hour, at room temperature the shelving of 1 hour, the test no abnormal adverse</p>
<p>4.4 高温动作 High-temperature operation</p>	<p>Temperature of 50°C, humidity of 20 ~ 30% work 16 hours at room temperature the shelving of 1 hour , test no abnormal adverse</p>
<p>4.5 低温动作 Low-temperature operation</p>	<p>Temperature of -20°C, work 16 hours at room temperature the shelving of 1 hour , test no abnormal adverse</p>
<p>4.6 耐湿性 Humidity Test</p>	<p>Temperature of 40 ± 2°C, humidity of 90 ~ 95% for 96 hour, at room temperature the shelving of 1 hour, the test no abnormal adverse</p>
<p>4.7 温/湿度循环试验 Composite temperature/humidity cyclic test</p>	<p>Refer to JIS C 60068-2-38, The loudspeaker shall be subjected to 10 continuous cycles , the loud speaker shall be stored at standard atmospheric conditions for 6 H for recovery. After the test should be able to meet the requirements of section 3.7, There shall be no distinct deformation in appearance.</p>
<p>4.8 振动测试 Vibration test</p>	<p>To be no interference in operation after vibration 10HZ~55HZ for 1 minute full amplitude 2mm for 8hours at X,Y,Z, three axes, After the test should be able to meet the requirements of section 3.7, There shall be no distinct deformation in appearance.</p>
<p>4.9 跌落测试 Drop test</p>	<p>Packaging The speaker from height 60 CM Down to concrete floors .in five directions Trial one cycles , After the test should be able to meet the requirements of section 3.7。</p>

5.制品外观图 Product Size

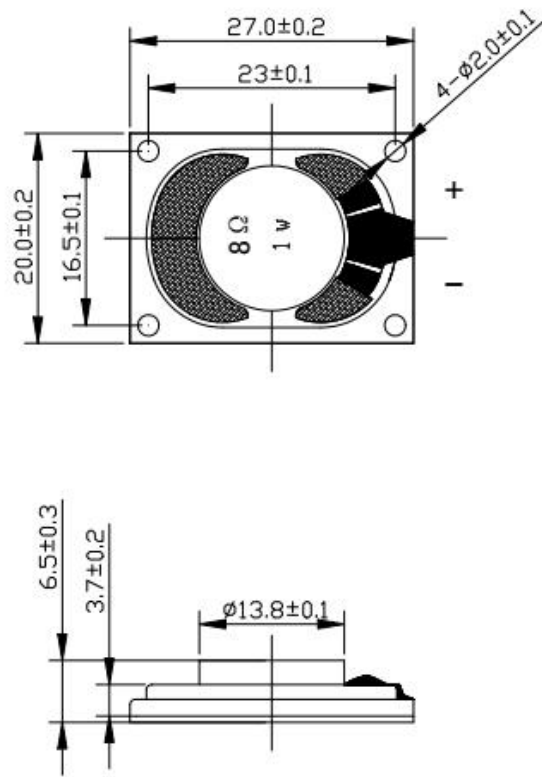

Unit: mm



6. 制品测试曲线图 Product testing curve

