

# 規格承認書

## PECIFICATION FOR APPROVAL

客 戶  
CUSTOMER : 通用型规格书 电压范围 3-24V  
項 目  
ITEM : 压电有源蜂鸣器 (内含驱动电路)  
型 號  
TYPE : GPD3015L100-3-24V3500  
描述  
DESCRIPTION :  $\Phi 30.0 \times H15 \text{ mm}$  3500Hz 3-24V  $\geq 100\text{DB}$  ABS 材质 L=100 mm  
客戶料號  
CUSTOMER NO. :  
規格書號  
SPECIFICATION NO.:  
版 本  
EDITION NO. : V1.1  
日 期  
DATE : 20

### 客戶承認

#### CUSTOMER CONFIRM AND SIGN

檢查 TESTED BY	審核 CHECKED BY	承認 APPROVED BY

### 東莞市贏海電子有限公司

#### DONGUAN INGHAI ELECTRONICS CO.,LTD

製作 ISSUED BY	審查 CHECKED BY	確認 APPROVED BY
周明	李林	

地址：广东省东莞市长安镇上沙第五工业区新春路 1 号新春科技园 1001 号

電話 / TEL: 0769-83060958 傳真 / FAX: 0769-81608993

網址: [HTTP://WWW.INGHAI.COM](http://www.inghai.com)

# DONGGUAN INGHAI ELECTRONICS CO.,LTD

Model NO: GPD3015L100--24V3500

A: DIMENSIONS Unit:mm Tolerance:  $\pm 0.5$  线长 L100mm

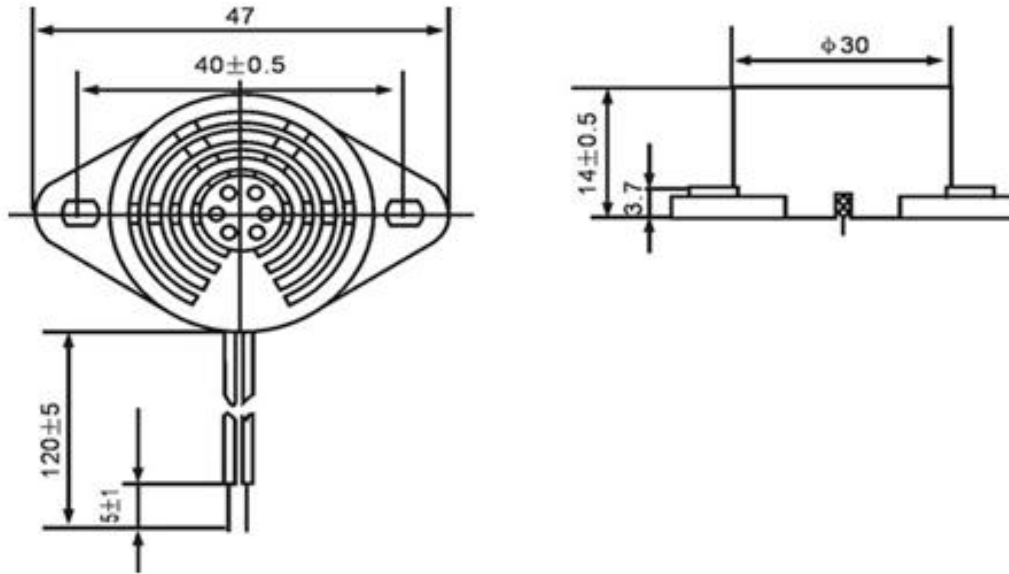

## B: SPECIFICATIONS

Model NO	GPD3015L100-3-24V3500
Rated Voltage	3-24VDC
Operating Voltage	3-25VDC
Max.Rated Current	$\leq 20$ mA
Sound Pressure level(dB/min) at 10cm	$\geq 100$ dB
Resonant Frequency	$3500 \pm 500$ Hz
Operating Temperature	-20 °C~+60 °C
Storage Temperature	-30 °C~+70 °C
Housing Material	ABS UL1571/26#

## Measuring condition

Part shall be measured under a condition (Temperature: 5 ~ 35°C, Humidity: 45% ~ 85%R.H., Atmospheric pressure: 860 ~ 1060hPa) unless the standard condition (Temperature: 25±3°C, Humidity: 60±10%R.H. Atmospheric pressure: 860 ~ 1060hPa) is regulated to measure.

## C: Reliability Test

After any following tests the part shall meet specifications without any degradation in appearance and performance except SPL. SPL shall not deviate more than -10 dB from the initial value

### 1. Ordinary Temperature Life Test

The part shall be subjected to 96 hours at 25 ± 10°C. Input rated voltage Resonant frequency, 1/2 duty Square wave.

### 2. High Temperature Test

The part shall be capable of with standing a storage temperature of +70°C for 96 hours.

### 3. Low Temperature Test

The part shall be capable of with standing a storage temperature of -30°C for 96 hours.

### 4. Humidity Test

Temperature: +40°C ± 3°C Relative Humidity: 90% ~ 95% Duration: 48 hours and expose to room temperature for 6 hours

### 5. Temperature Shock Test

Temperature: 60°C /1hour → 25°C/3hours → -30°C/1hour → 25°C/3hours (1cycle)  
Total cycle: 10 cycles

### 6. Drop Test

Standard Packaging From 120mm (Drop on hard wood or board of 5cm thick, three sides, six plain.)

### 7. Vibration Test

Vibration: 1000cycles /min. Amplitude: 1.5mm, Duration: 1 hour in each 3 axes

## Note:

As this product is not protected from foreign material entering, please make sure that any foreign materials (e.g. magnetic powder, washing solvent, flux, corrosive gas) do not enter this product in your production processes. The functional degradation (e.g. SPL down) may occur if foreign material enter it.