



TAI-SAW TECHNOLOGY CO., LTD.

No. 3, Industrial 2nd Rd., Ping-Chen Industrial District,
Taoyuan, 324, Taiwan, R.O.C.

TEL: 886-3-4690038 FAX: 886-3-4697532

E-mail: tstsales@mail.taisaw.com Web: www.taisaw.com

Product Specifications Approval Sheet

Product Description: SAW Filter 2310 MHz SMD 3.0x3.0 mm (BW=10 MHz)

TST Part No.: TA1786A

Customer Part No.: _____

Customer signature required
Company: _____
Division: _____
Approved by : _____
Date: _____

Checked by: _____ David Chang 

Approved by: _____ Bob Chau 

Date: _____ 2014/07/30

1. Customer signed back is required before TST can proceed with sample build and receive orders.
2. Orders received without customer signed back will be regarded as agreement on the specifications.
3. Any specifications changes must be approved upon by both parties and a new revision of specifications shall be released to reflect the changes.



TAI-SAW TECHNOLOGY CO., LTD.

No. 3, Industrial 2nd Rd., Ping-Chen Industrial District,
Taoyuan, 324, Taiwan, R.O.C.

TEL: 886-3-4690038 FAX: 886-3-4697532

E-mail: tstsales@mail.taisaw.com Web: www.taisaw.com

SAW Filter 2310 MHz

MODEL NO.: TA1786A

REV. NO.:1

A. MAXIMUM RATING:

1. Input Power Level: 13 dB_m
2. DC voltage: 5 V
3. Operating Temperature: -30°C to +85°C
4. Storage Temperature: -40°C to +85°C

RoHS Compliant
Lead free
Lead-free soldering

Electrostatic Sensitive Device (ESD)

B. ELECTRICAL CHARACTERISTICS:

Item	Unit	Min.	Typ.	Max.
Center frequency F_c	MHz	-	2310	-
Insertion Loss (2305~2315 MHz) IL	dB	-	3.6	3.9
Amplitude Ripple (2305~2315 MHz)	dB	-	0.5	1.5
VSWR (2305~2315 MHz)	ns	-	1.4	2.5
Attenuation (Reference level from 0 dB)				
1928 ~ 1933 MHz	dB	42	49	-
2095 ~ 2110 MHz	dB	35	50	-
2350 ~ 2360 MHz	dB	25	47	-
2620 ~ 3600 MHz	dB	27	43	-
Temperature coefficient of frequency	ppm/k	-	-36	-

C. MEASUREMENT CIRCUIT:

HP Network analyzer

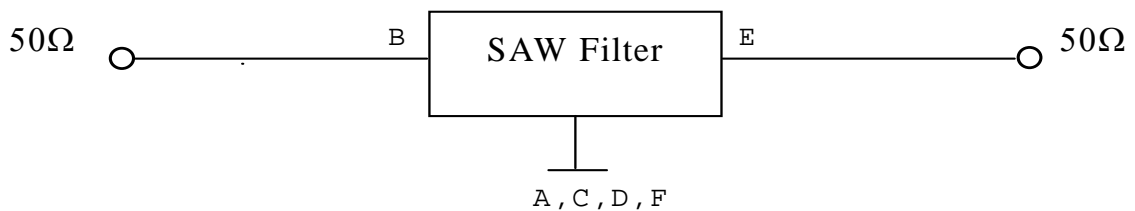

D. Frequency Characteristics:

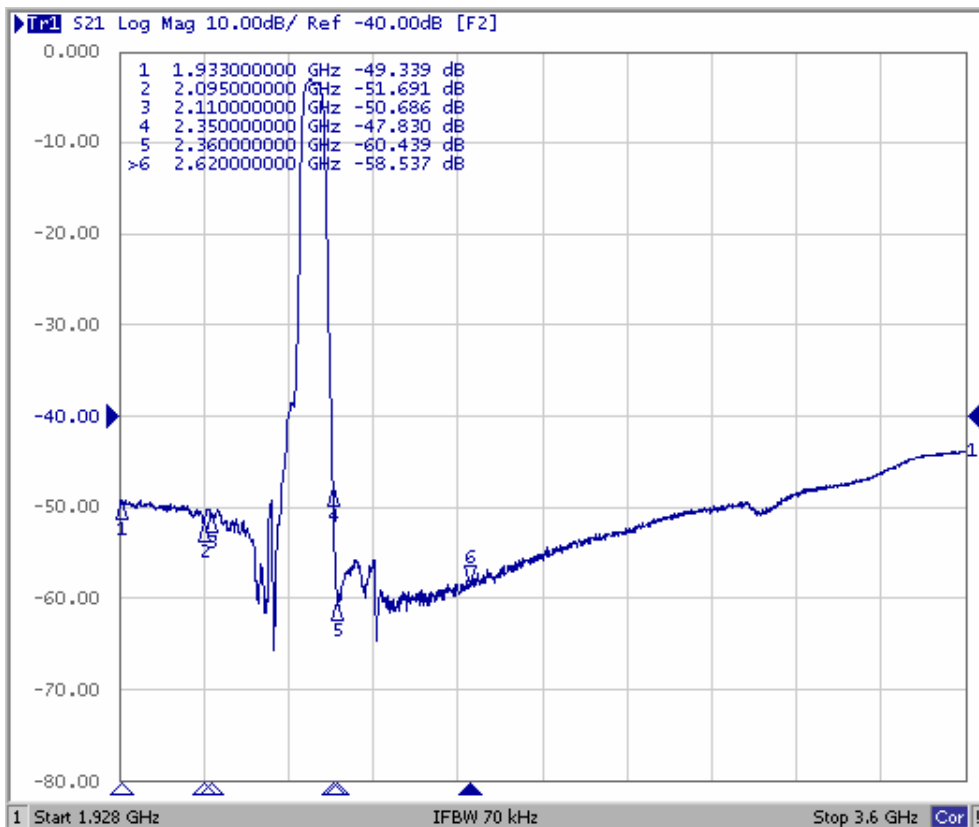
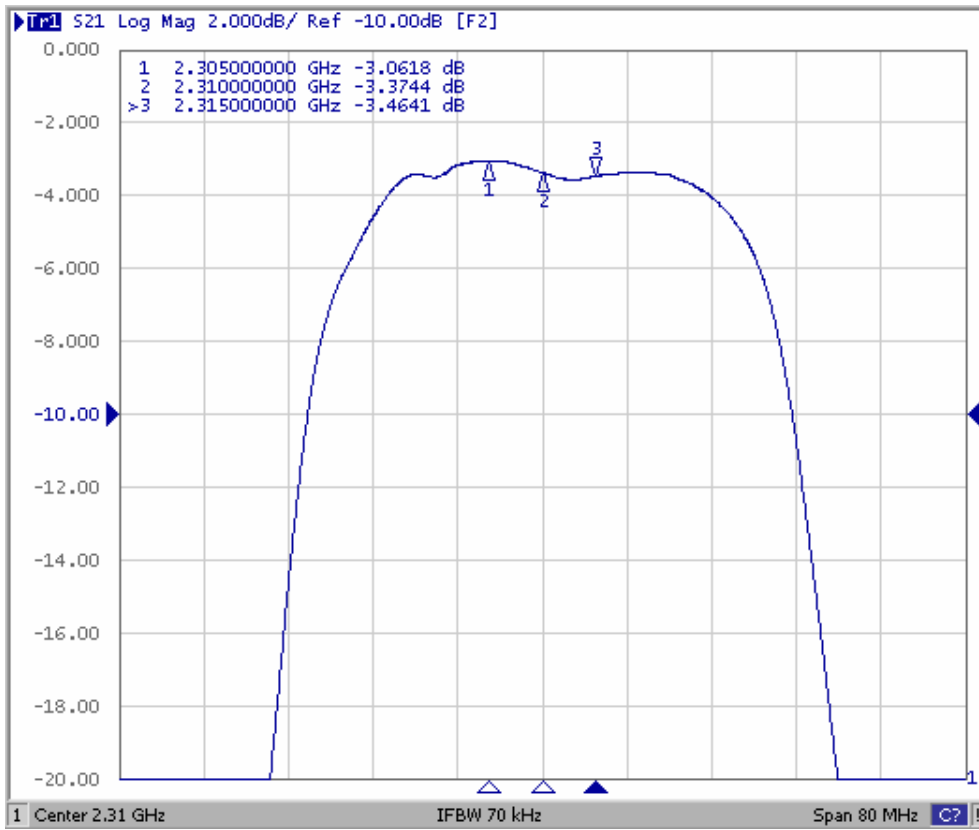

Reflection Functions:

S11

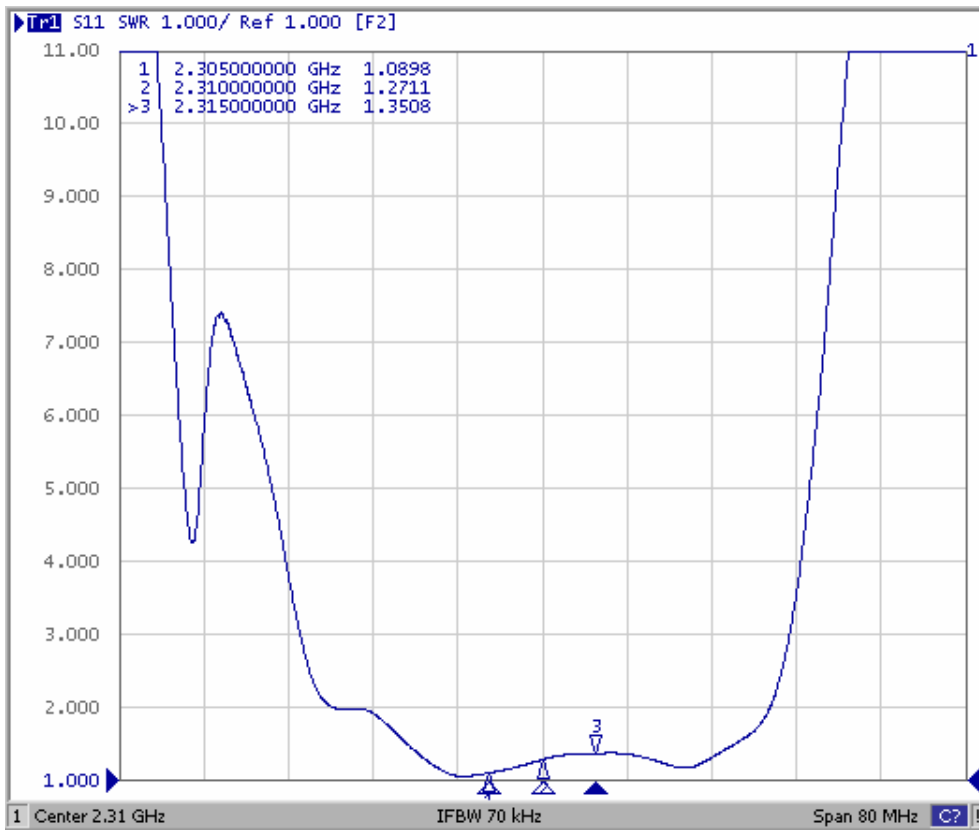

S22

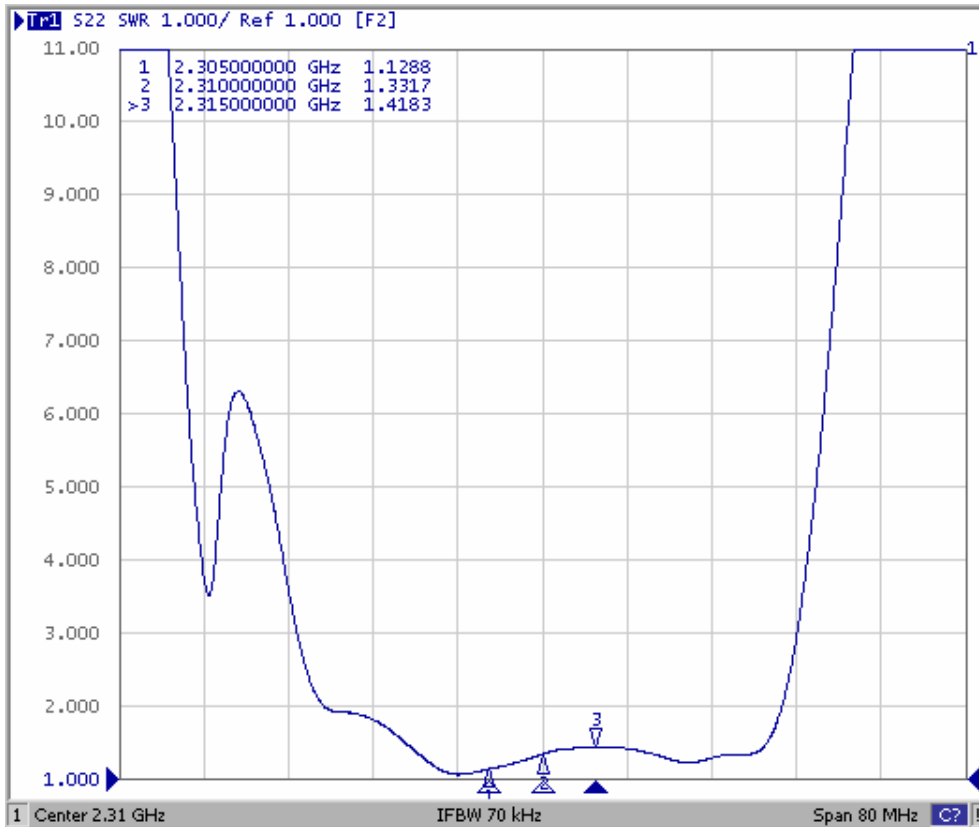

E. OUTLINE DRAWING:

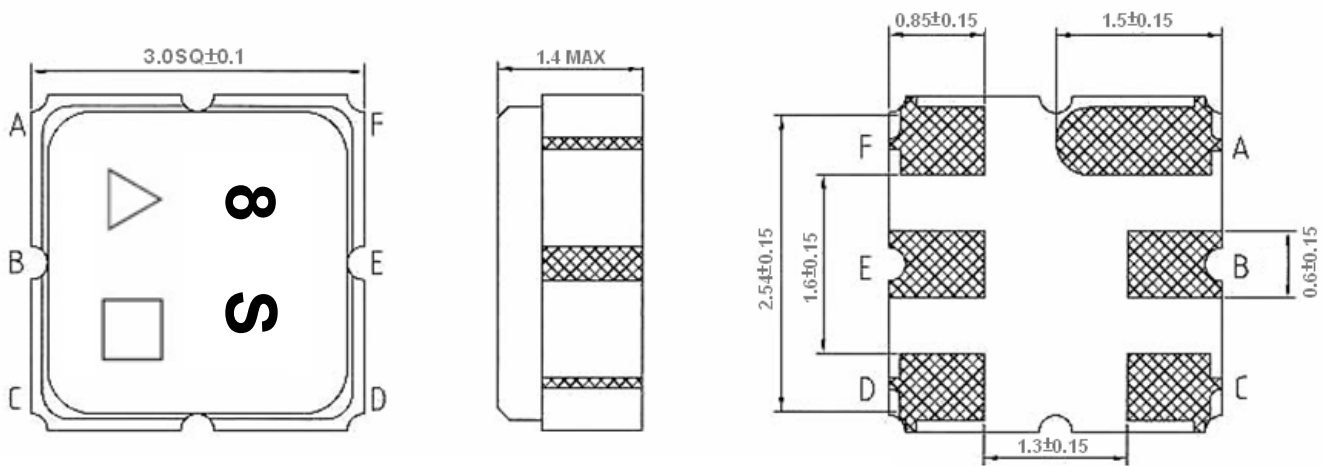

B: Input

E: Output

A, C, D, F: Ground

Unit: mm

△ : Year Code (2011->1, 2012->2, ..., 2019->9, 2020->0)

□ : Date Code

Date Code Table:

WK01	WK02	WK03	WK04	WK05	WK06	WK07	WK08	WK09	WK10	WK11	WK12	WK13
A	B	C	D	E	F	G	H	I	J	K	L	M
WK14	WK15	WK16	WK17	WK18	WK19	WK20	WK21	WK22	WK23	WK24	WK25	WK26
N	O	P	Q	R	S	T	U	V	W	X	Y	Z
WK27	WK28	WK29	WK30	WK31	WK32	WK33	WK34	WK35	WK36	WK37	WK38	WK39
a	b	c	d	e	f	g	h	i	j	k	l	m
WK40	WK41	WK42	WK43	WK44	WK45	WK46	WK47	WK48	WK49	WK50	WK51	WK52
n	o	p	q	r	s	t	u	v	w	x	y	z

F. PCB Footprint:

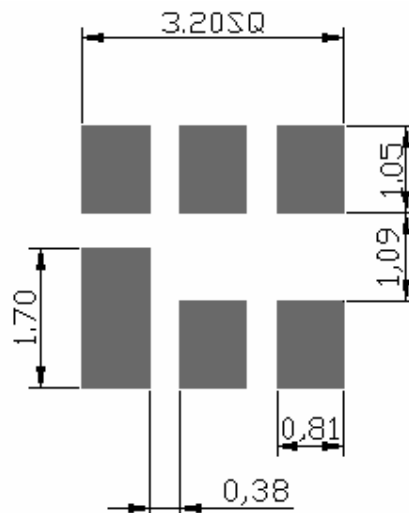

G. PACKING:

1. REEL DIMENSION

(Please refer to FR-75D10 for packing quantity)

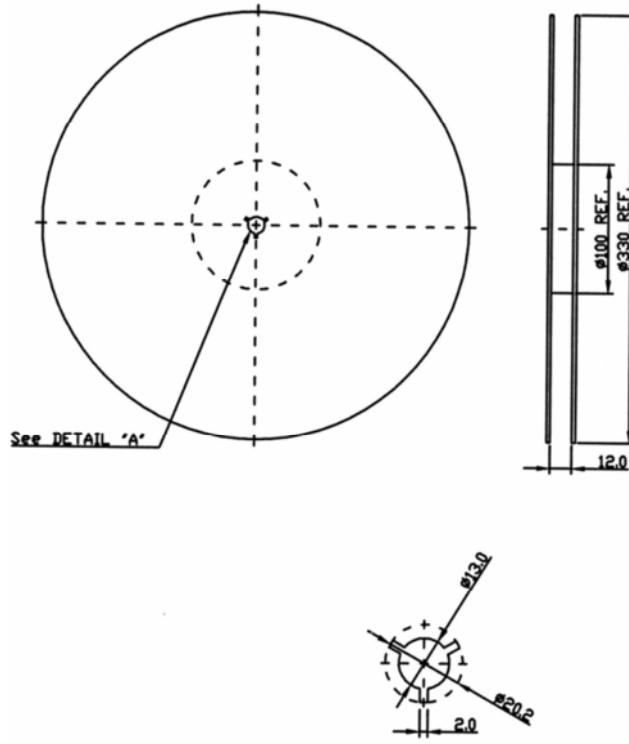

2. TAPE DIMENSION

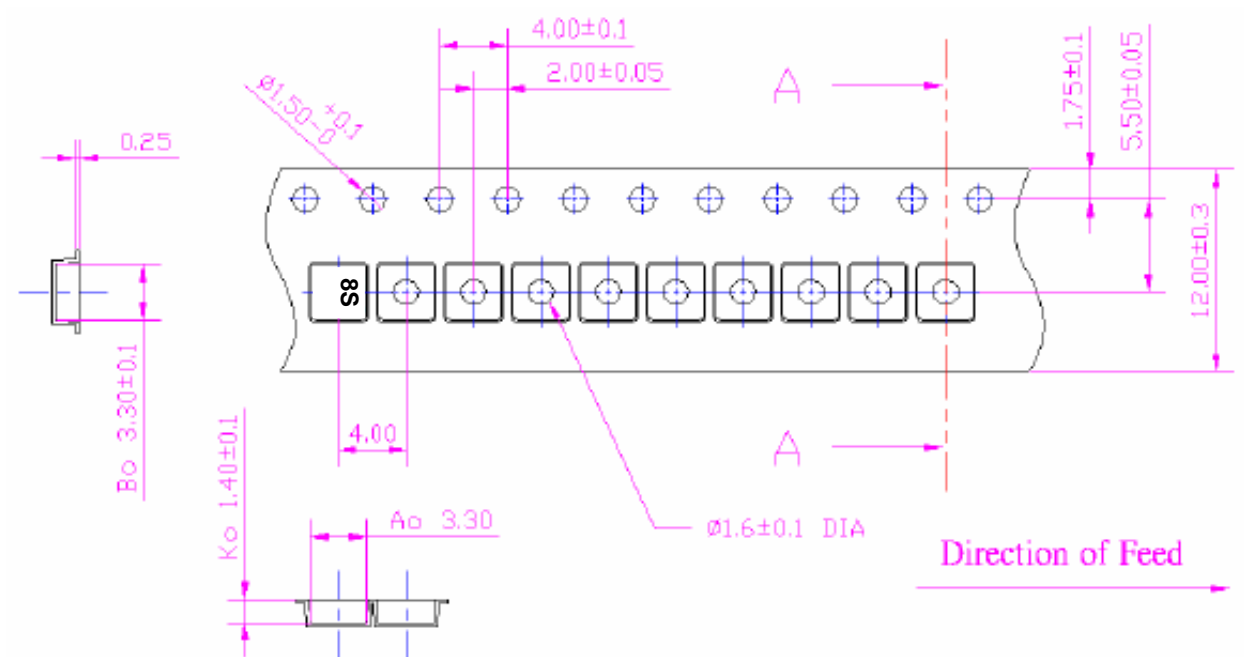

H. RECOMMENDED REFLOW PROFILE:

