

Features

- 4.75~36Vin(3.3Vout).6.5-36Vin(5.0Vout)
- Fixed Output: 3.3 or 5V @ 2A
- Vertical SIP, small footprint package
- “No heat sink” direct replacement for 3-terminal78xx-series linear regulators
- High efficiency with no external components
- Short circuit protection
- Outstanding thermal derating performance
- UL/EN/IEC 60950-1, 2nd Edition safety meets



Description

The K78XX-2000R3 Series are non-isolated DC/DC converters suited to replace 2Amp LM78xx linear regulators. Designed with highly efficiency, allow the operating temperature range of these units to be -40°C to +85°C in a 11.6*8.5*17.5mm. Further features include wide 4.75~36VDC input voltage range, short-circuits protection and over temperature protection.

Technical Specification

All specifications are typical at nominal input, full load and 25°C unless otherwise stated.

Model Number	Input Voltage Range	Output Voltage (V)	Output Current (mA)		Eff .(2) (%)		Capacitive Load, max. (3) (uF)
			Min. Load (1)	Full. Load	Vin_min	Vin_max.	
K7803-2000R3	4.75-36V Nominal:12V	3.3	0	2000	90	86	1800
K7805-2000R3	6.5-36V Nominal:12V	5	0	2000	93	90	1000

Input Specifications

Input voltage	K7803-2000R3 K7805-2000R3	12V nominal input 12V nominal input	4.75-36V 6.5-36V
Input filter	Capacitor type		
Input Reverse Polarity	None, install external fuse(2A Fast blow)		
No Load Input Current	10mA Typ.		
Hot swap is not supported			

Environmental Specifications

Operating ambient temperature	-40°C to +85°C (with derating)
Storage temperature range	-55°C to +125°C
Relative humidity	5% TO 95% RH max.
Temperature coefficient	±0.02% / °C Typ.
RoHS Compliant	RoHS 2.0

Output Specifications

Output current	2A max.		
Voltage accuracy	At 50% load	-4% Min. +4% Max.	
Minimum load	(No minimum load)	0mA	
Line regulation	Vin=min. to max. Vout=nom.	±0.4% Typ ±0.8% max.	

Load Regulation	10 -100% load	±0.5% Typ ±1.5% max
Ripple and Noise (20MHz Bandwidth)		75mVp-p max.
Capacitive load		2200uS max
Over Current Protection(OCP)	100%=1A	200% Typ 250% max
Short Circuit Protection(SCP)	Continuous, autorecovery	
General Specifications		
Efficiency		See table
Switching frequency (Fixed)	Pulse width modulation (PWM)	410kHz Typ
Dynamic load response	75-100-75% 25%load step	100uS Typ
Reliability, calculated MTBF	K7803-2000R3/ K7805-2000R3	2.0×10 ⁶ Hrs
Safety ⁽⁵⁾	UL-60950-1,IEC/EN60950-1,2nd Edition	meet
Physical Specifications		
Dimensions		0.45 × 0.33 × 0.68 Inch (11.6 × 8.5 × 17.5 mm)
Weight		4g (0.142oz) typ.

Efficiency Curve

K7803-2000R3

Efficiency vs Line Voltage and Load Current@+25°C(V_{out}=V_{nom}.)

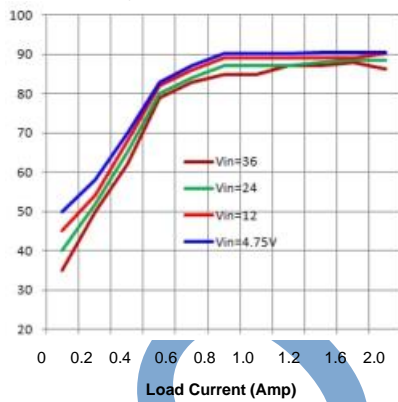

K7805-2000R3

Efficiency vs Line Voltage and Load Current@+25°C(V_{out}=V_{nom}.)

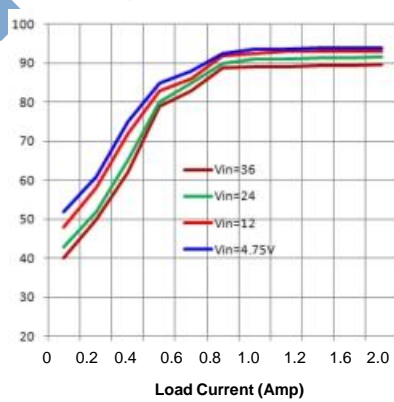

Power Derating Curve

Maximum Current Temperature Derating at sea level(V_{in}=6.5V to 36V)

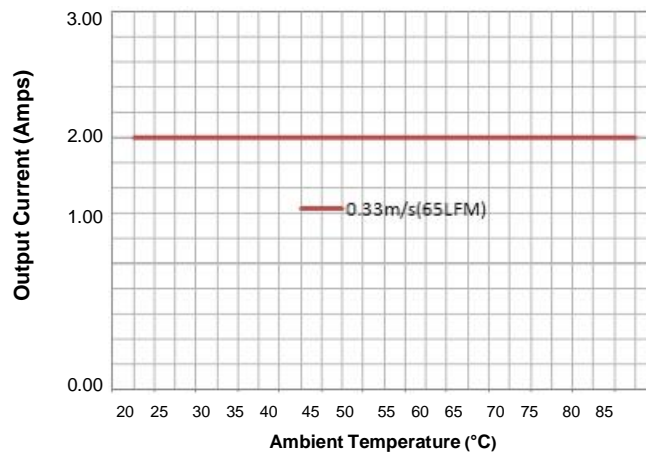

Note

1. Io below this value will not damage these converters, however, they may not meet all listed specifications.
2. Typical value, tested at nominal input and full load.
3. Specifications subject to change without notice.
4. This power module is not internally fused. The input line fuse must always be used.
5. Input Back Ripple Current is tested and specified over a 5 Hz to 20 MHz bandwidth.
Input filtering is $C_{in}=2 \times 100 \mu F$, $C_{bus}=1000 \mu F$, $L_{bus}=1 \mu H$. All caps are low ESR types.

Mechanical Dimensions

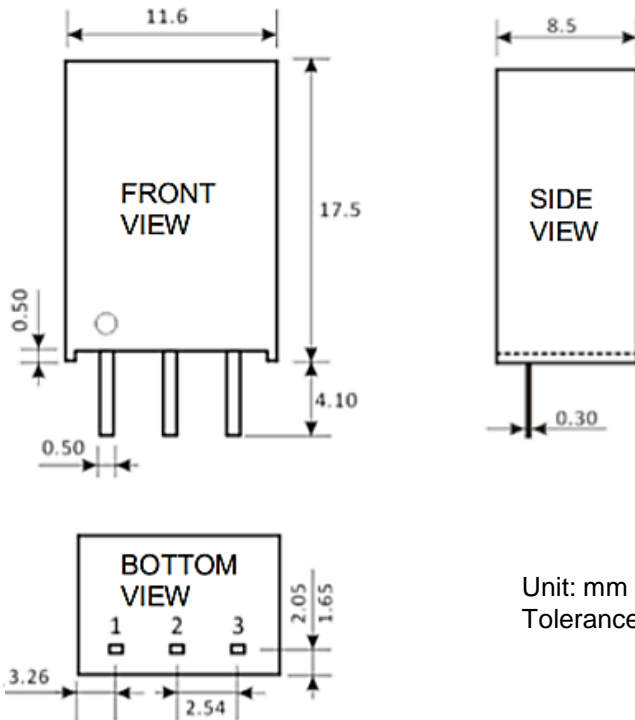

Pin Assignment	
Pin	Define
1	Positive Input
2	Common(Ground)
3	Positive Output

Unit: mm
Tolerance: XX.X=±0.5, XX.XX=±0.25

Package Information

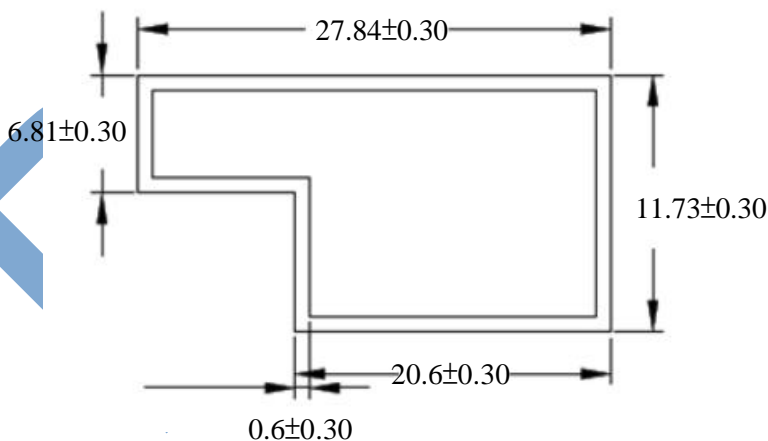

PS:
Unit: mm [inch]
L= 220 mm[8.66 inch] ; ONE TUBE = 16 PCS

Test Configurations

All specifications are typical at nominal input, full load and 25°C unless otherwise stated.

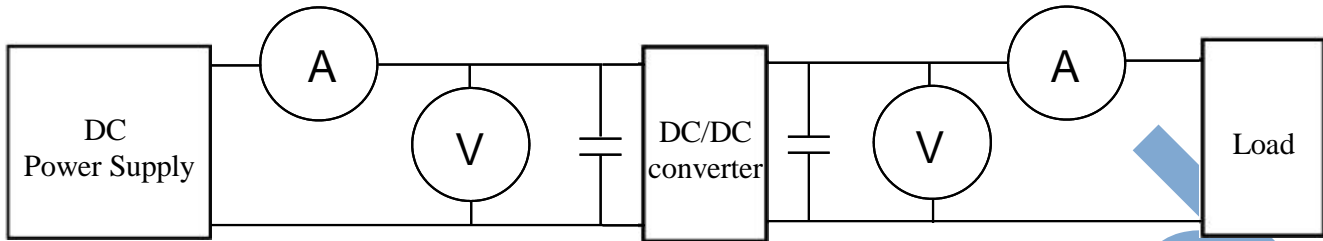

- ⊙DC Power Supply: It offers a wide voltage and current range precisely.
- ⊙Current meter (A): Accuracy → 200μA ~ 200mA 4 ranges $\pm(0.2\% \text{ rdg} + 2 \text{ digits})$
2000mA ~ 20A 2 ranges $\pm(0.3\% \text{ rdg} + 2 \text{ digits})$.
- ⊙Voltage meter (V): Accuracy → $\pm(0.03\% \text{ rdg} + 4 \text{ digits})$.
- ⊙Load: At full load.
- ⊙Wires: The resistance of the wires must be small.

1. **Ripple and Noise**: as shown below. The bandwidth is 0-20MHz.

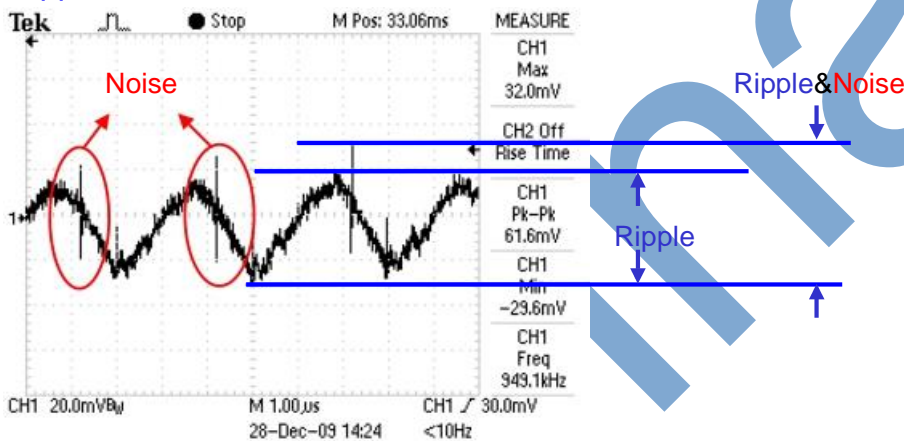

Output Ripple&Noise measurement test circuit: as shown below.

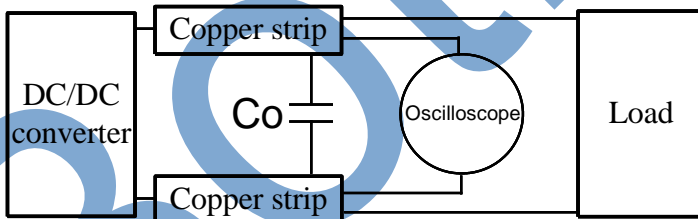

Co: usually 10uF to 47uF use low-ESR ceramic.

2. **Temperature derating curve**: The DC-DC converter will operate over a wider temperature range if less power is drawn from the output and the device is already running. The temperature derating curve shows the operating power-temperature range. As shown below.

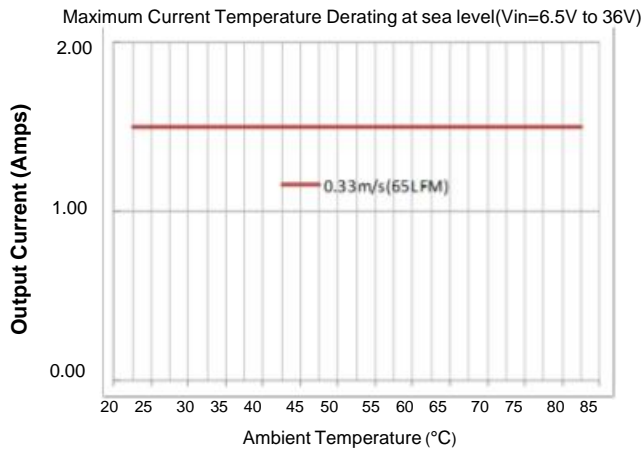

3. Application circuit: as shown below. $C_1=10\mu F/50V$ MLCC, $C_2=47\mu F/16V$ MLCC.

