

Features

- Efficiency up to 94%, no heatsinks required
- Pin-out compatible with LM78XX linears
- Low profile (L/W/H=11.6 x 10.4 x 7.6mm)
- Short circuit protection, thermal shutdown
- Operating ambient temperature range: -40°C to +85°C
- EN/IEC 60950-1, 2nd Edition, EN55032 safety meets

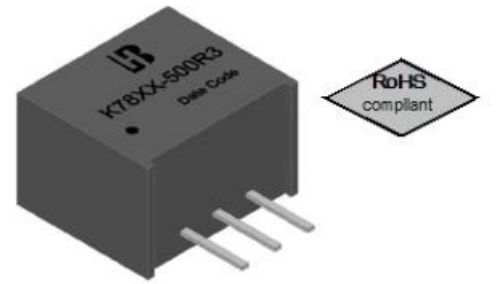

Description

The K78KXX-500R3-Series are high efficiency switching regulators and ideal substitutes for LM78xx series three-terminal linear regulators. The converters feature high efficiency, low loss, short circuit protection, and there is no need for a heat sink.

These products are widely used in applications such as industrial control, instrumentation and electric power.

Technical Specification

All specifications are typical at nominal input, full load and 25°C unless otherwise stated.

Model Number	Input Voltage Range	Output Voltage (V)	Output Current (mA)		Full Load Efficiency(%) Typ. Vin Min./ Vin Max.	Capacitive Load(uF) Max.
			Min. Load (1)	Full. Load		
K7803-500R3	4.75-36V Nominal: 24V	3.3	0	500	86/80	680
K7805-500R3	6.5-36V Nominal: 24V	5	0	500	93/84	680
K7812-500R3	15-36V Nominal: 24V	12	0	500	94/91	680

Input Specifications		
Input voltage	24V nominal input	4.75V Min. 36V max.
Input filter		Capacitor
Input Reverse Polarity	See Positive to Negative Converter, install external fuse(1A Fast blow)	
No Load Input Current		1.5mA max.
Short Circuit Input Current		10mA Typ,30mA max.
Hot swap is not supported		
Environmental Specifications		
Operating ambient temperature	with derating	-40°C to +85°C
Storage temperature range		-55°C to +125°C
Maximum case temperature		+100°C
Operating humidity	Non-condensing	95% RH max.
Temperature coefficient		±0.015% / °C Typ.
RoHS Compliant		RoHS 2.0
Output Specifications		
Voltage accuracy	At 100% load	±2.0% Typ ±4.0% max.
Line regulation	Vin=min. to max. Vout=100% load	±0.4% Typ ±1.0% max.
Load Regulation	Vin=nom. Vout=10 -100% load	±0.3% Typ ±0.6% max.
Ripple and Noise (20MHz Bandwidth) ⁽⁴⁾	Vin=nom. Vout=100% load	75mVp-p Typ. 100mVp-p max.
Capacitive load		680uF max
Over Current Protection(OCP)	100%=0.5A	200~400%
Short Circuit Protection (SCP)		Continuous, autorecovery
General Specifications		
Efficiency		See table
Switching frequency	Pulse width modulation(PWM), Vin=nom.	2MHz
Dynamic load response	75-100-75% load step	<75uS Typ
MTBF	According to MIL-HDBK-217F,G.B. +25°C	2.0×10 ⁶ Hrs min
Safety ⁽⁵⁾	IEC/EN60950-1,2nd Edition,EN55032	meet
Physical Specifications		
Dimensions		0.45 × 0.41 × 0.3 Inch (11.6 × 10.4 × 7.6 mm)
Weight		2.0g (0.07oz) typ.
EMC Compliance		
	Condition	Standard/Criterion
Electromagnetic compatibility of multimedia equipment-Emission requirements	with external components	EN55032,Class A EN55032,Class B
ESD Electrostatic discharge immunity test	Air ±8kV,Contact ±4kV	EN61000-4-2,Criteria B
Radiated,radio-frequency,electromagnetic field immunity test	10V/m	EN61000-4-3,Criteria A

Power Derating Curve

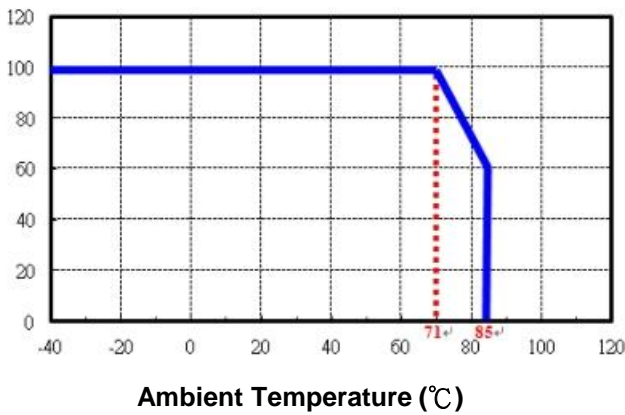

Efficiency Curve

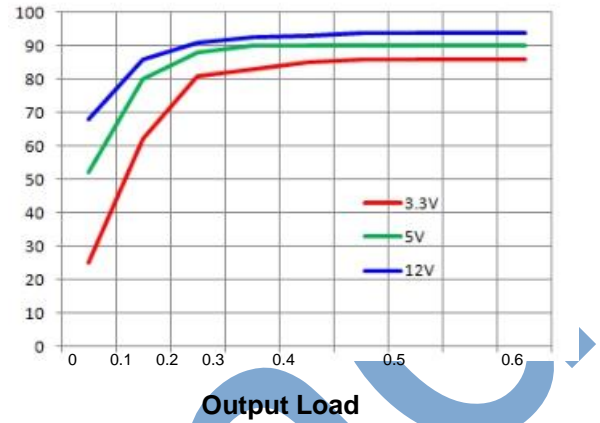

Note

1. Io below this value will not damage these converters, however, they may not meet all listed specifications.
2. Typical value, tested at nominal input and full load.
3. Operation under no load will not harm the converter, but specifications may not be met A minimum load of 10mA is recommended
4. With light loads at or below 10%, Ripple & Noise for 3.3V/5V output parts increases to 150mVp-p max, and for Other output parts to 2%Vo max.
5. Input Back Ripple Current is tested and specified over a 5 Hz to 20 MHz bandwidth. Input filtering is Cin=100 uF, Cbus=100 uF, Lbus=1 uH. All caps are low ESR

Mechanical Dimensions

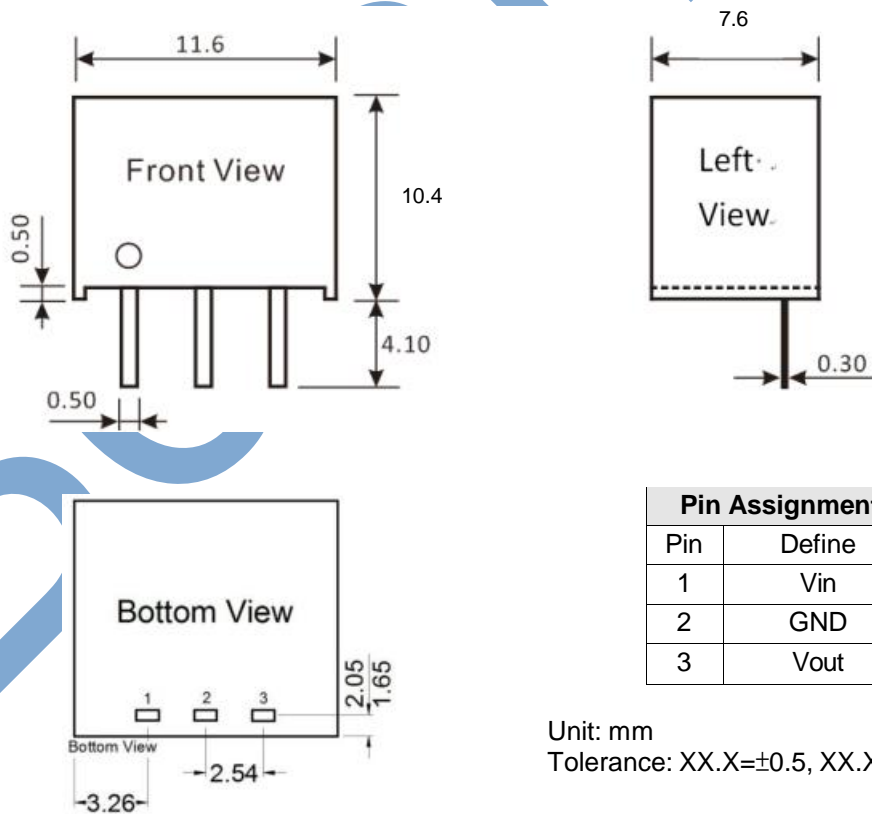

Pin Assignment	
Pin	Define
1	Vin
2	GND
3	Vout

Unit: mm
Tolerance: XX.X=±0.5, XX.XX=±0.25

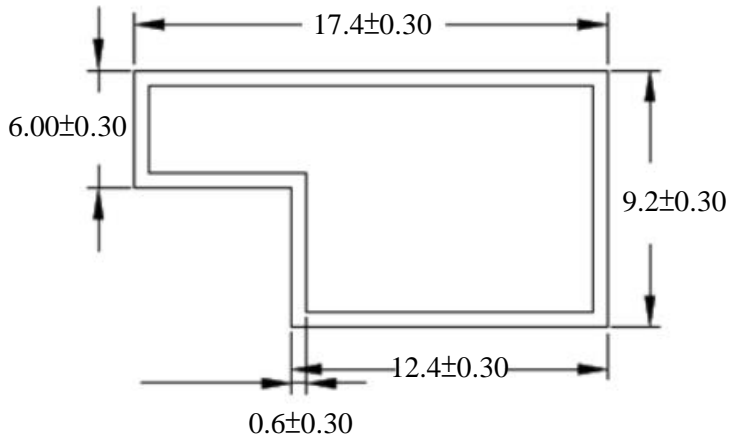
Package Information

PS:

Unit: mm [inch]

L= 520 mm[20.47 inch] ; ONE TUBE = 42 PCS

Bothhand

Test Configurations

All specifications are typical at nominal input, full load and 25°C unless otherwise stated.

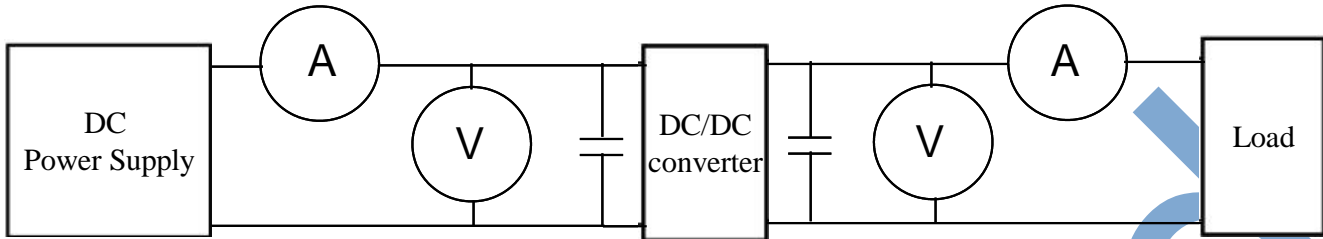

- ⊙DC Power Supply: It offers a wide voltage and current range precisely.
- ⊙Current meter (A): Accuracy → 200μA ~ 200mA 4 ranges $\pm(0.2\% \text{ rdg} + 2 \text{ digits})$
2000mA ~ 20A 2 ranges $\pm(0.3\% \text{ rdg} + 2 \text{ digits})$.
- ⊙Voltage meter (V): Accuracy → $\pm(0.03\% \text{ rdg} + 4 \text{ digits})$.
- ⊙Load: At full load.
- ⊙Wires: The resistance of the wires must be small.

1. Ripple and Noise: as shown below. The bandwidth is 0-20MHz.

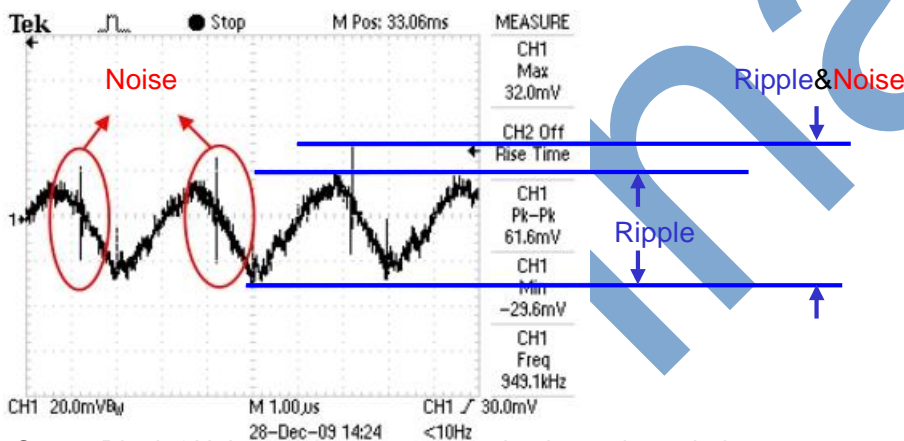

Output Ripple&Noise measurement test circuit: as shown below.

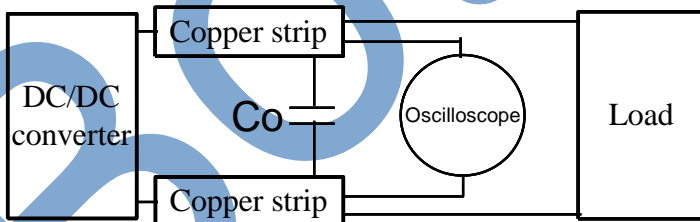

Co: usually 10uF to 47uF use low-ESR ceramic.

2. Application circuit: as shown below. C1=4.7uF/100V MLCC, C2 =100uF/25V Low ESR.

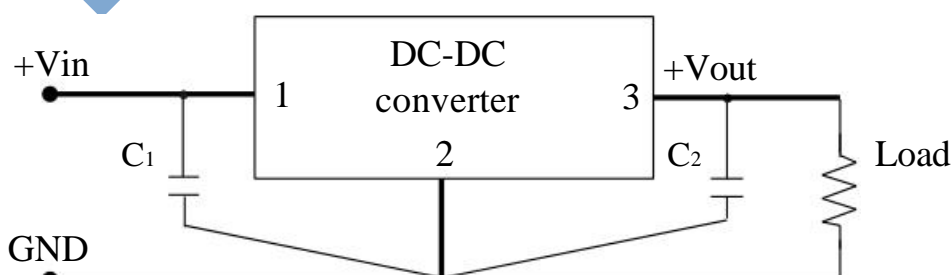

External components circuit

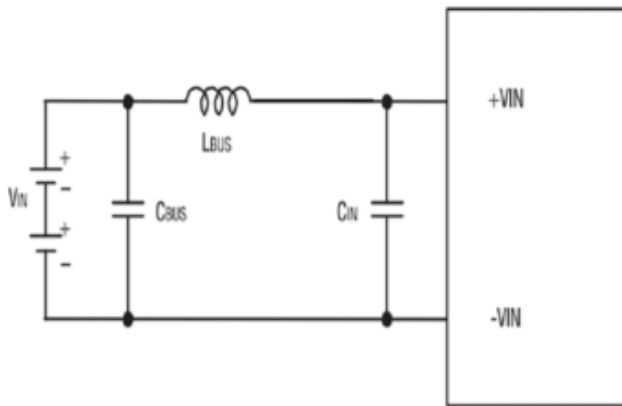

$C_{IN} = 2 \times 100 \mu F$, $ESR < 700 m\Omega$ @ 100kHz

$C_{BUS} = 100 \mu F$, $ESR < 100 m\Omega$ @ 100kHz

$C_{BUS} = 1 \mu F$

Positive to Negative Converter

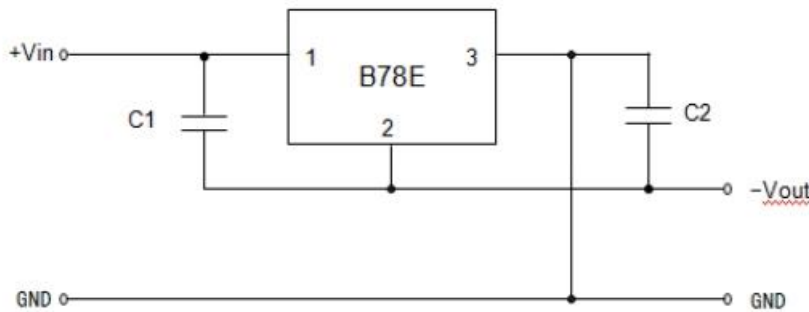

$C1$ and $C2$ are required and should be fitted close to the converter pins.

Maximum capacitive load including $C2$ is 100 μF