



10N70K

Power MOSFET

10A, 700V N-CHANNEL POWER MOSFET

DESCRIPTION

The UTC **10N70K** is an N-channel Power MOSFET using UTC's advanced technology to provide customers a minimum on-state resistance and superior switching performance, etc.

The UTC **10N70K** is generally applied in high efficient DC to DC converters, PWM motor controls and bridge circuits, etc.

FEATURES

- * $R_{DS(ON)} < 1.2\Omega$ @ $V_{GS} = 10V, I_D = 5A$
- * Low Gate Charge (Typical 44nC)
- * Low C_{RSS} (typical 10 pF)
- * High Switching Speed
- * Improved dv/dt capability

SYMBOL

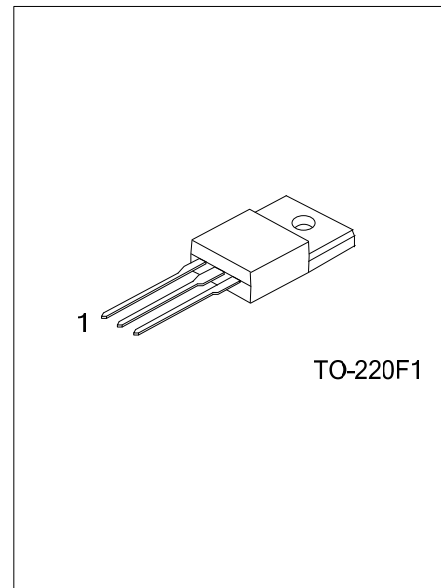
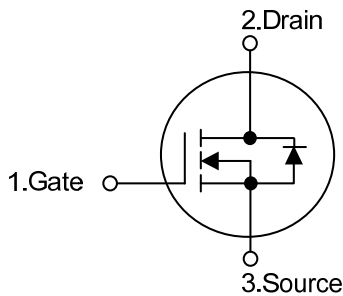

ORDERING INFORMATION

Ordering Number		Package	Pin Assignment			Packing
Lead Free	Halogen Free		1	2	3	
10N70KL-TF1-T	10N70KG-TF1-T	TO-220F1	G	D	S	Tube

Note: Pin Assignment: G: Gate D: Drain S: Source

<p>10N70KL-TF1-T</p> <p>(1) Packing Type (2) Package Type (3) Lead Free</p>	<p>(1) T: Tube (2) TF1: TO-220F1 (3) L: Lead Free, G: Halogen Free</p>
---	--

MARKING

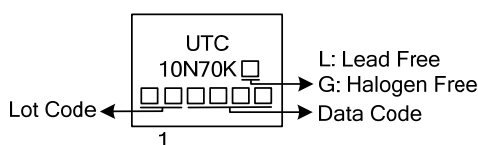

■ ABSOLUTE MAXIMUM RATINGS ($T_C = 25^\circ\text{C}$ unless otherwise specified)

PARAMETER	SYMBOL	RATINGS	UNIT
Drain-Source Voltage	V_{DSS}	700	V
Gate-Source Voltage	V_{GSS}	± 30	V
Avalanche Current (Note 2)	I_{AR}	10	A
Drain Current	Continuous	I_D	10
	Pulsed (Note 2)	I_{DM}	38
Avalanche Energy	Single Pulsed (Note 3)	E_{AS}	150
Peak Diode Recovery dv/dt (Note 4)	dv/dt	4.5	V/ns
Power Dissipation	P_D	50	W
Junction Temperature	T_J	+150	$^\circ\text{C}$
Operating Temperature	T_{OPR}	-55 ~ +150	$^\circ\text{C}$
Storage Temperature	T_{STG}	-55 ~ +150	$^\circ\text{C}$

Notes: 1. Absolute maximum ratings are those values beyond which the device could be permanently damaged.

Absolute maximum ratings are stress ratings only and functional device operation is not implied.

2. Repetitive Rating: Pulse width limited by maximum junction temperature

3. $L = 3\text{mH}$, $I_{AS} = 10\text{A}$, $V_{DD} = 50\text{V}$, $R_G = 25\ \Omega$ Starting $T_J = 25^\circ\text{C}$

4. $I_{SD} \leq 9.5\text{A}$, $di/dt \leq 200\text{A}/\mu\text{s}$, $V_{DD} \leq BV_{DSS}$, Starting $T_J = 25^\circ\text{C}$

■ THERMAL DATA

PARAMETER	SYMBOL	RATING	UNIT
Junction to Ambient	θ_{JA}	62.5	$^\circ\text{C}/\text{W}$
Junction to Case	θ_{JC}	2.5	$^\circ\text{C}/\text{W}$

■ ELECTRICAL CHARACTERISTICS($T_C=25^{\circ}\text{C}$, unless otherwise specified)

PARAMETER	SYMBOL	TEST CONDITIONS	MIN	TYP	MAX	UNIT
OFF CHARACTERISTICS						
Drain-Source Breakdown Voltage	BV_{DSS}	$V_{GS} = 0V, I_D = 250\mu A$	700			V
Drain-Source Leakage Current	I_{DSS}	$V_{DS} = 700V, V_{GS} = 0V$			1	μA
Gate-Source Leakage Current	Forward	$V_{GS} = 30V, V_{DS} = 0V$ $V_{GS} = -30V, V_{DS} = 0V$			100	nA
	Reverse				-100	nA
Breakdown Voltage Temperature Coefficient	$\Delta BV_{DSS}/\Delta T_J$	$I_D=250\mu A$, Referenced to 25°C		0.7		$V/^{\circ}\text{C}$
ON CHARACTERISTICS						
Gate Threshold Voltage	$V_{GS(TH)}$	$V_{DS} = V_{GS}, I_D = 250\mu A$	2.0		4.0	V
Static Drain-Source On-State Resistance	$R_{DS(ON)}$	$V_{GS} = 10V, I_D = 5.0A$		1.0	1.2	Ω
DYNAMIC CHARACTERISTICS						
Input Capacitance	C_{ISS}	$V_{DS}=25V, V_{GS}=0V, f=1.0\text{ MHz}$		1150	1712	pF
Output Capacitance	C_{OSS}			108	125	pF
Reverse Transfer Capacitance	C_{RSS}			10	13	pF
SWITCHING CHARACTERISTICS						
Total Gate Charge	Q_G	$V_{DS}=520V, I_D=10A, V_{GS}=10V$ (Note 1, 2)		95	110	nC
Gate-Source Charge	Q_{GS}			8		nC
Gate-Drain Charge	Q_{GD}			14		nC
Turn-On Delay Time	$t_{D(ON)}$	$V_{DD}=325V, I_D = 10A, R_G = 25\Omega$ (Note 1, 2)		90	100	ns
Turn-On Rise Time	t_R			30	90	ns
Turn-Off Delay Time	$t_{D(OFF)}$			210	300	ns
Turn-Off Fall Time	t_F			46	105	ns
DRAIN-SOURCE DIODE CHARACTERISTICS AND MAXIMUM RATINGS						
Maximum Continuous Drain-Source Diode Forward Current	I_S				10	A
Maximum Pulsed Drain-Source Diode Forward Current	I_{SM}				38	A
Drain-Source Diode Forward Voltage	V_{SD}	$V_{GS} = 0V, I_S = 10A$			1.4	V
Reverse Recovery Time	t_{rr}	$V_{GS} = 0V, I_S = 10A,$		420		ns
Reverse Recovery Charge	Q_{rr}	$dI_F / dt = 100\text{ A}/\mu\text{s}$ (Note 1)		4.2		μC

Notes: 1. Pulse Test : Pulse width $\leq 300\mu\text{s}$, Duty cycle $\leq 2\%$.

2. Essentially independent of operating temperature.

■ TEST CIRCUITS AND WAVEFORMS

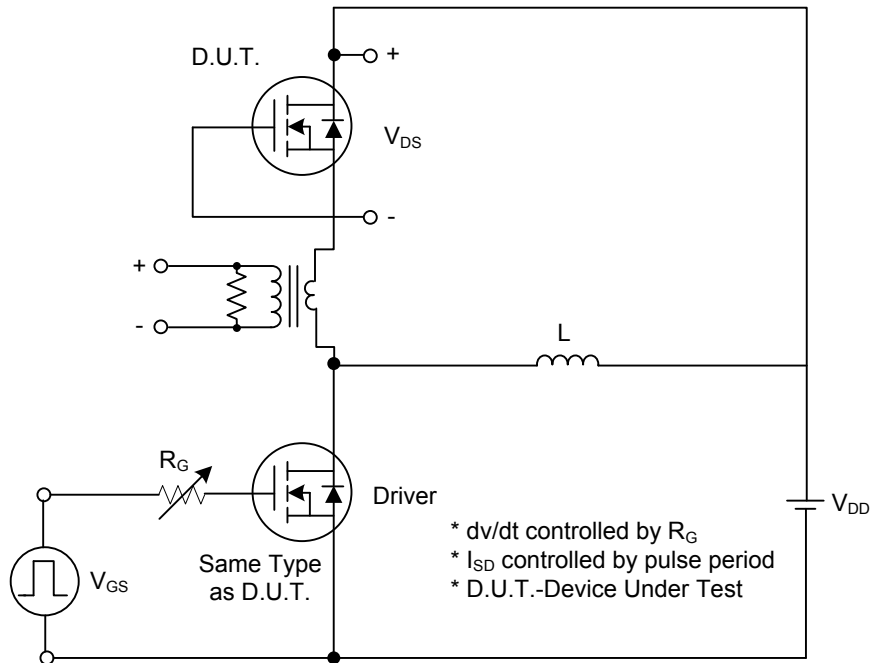

Peak Diode Recovery dv/dt Test Circuit

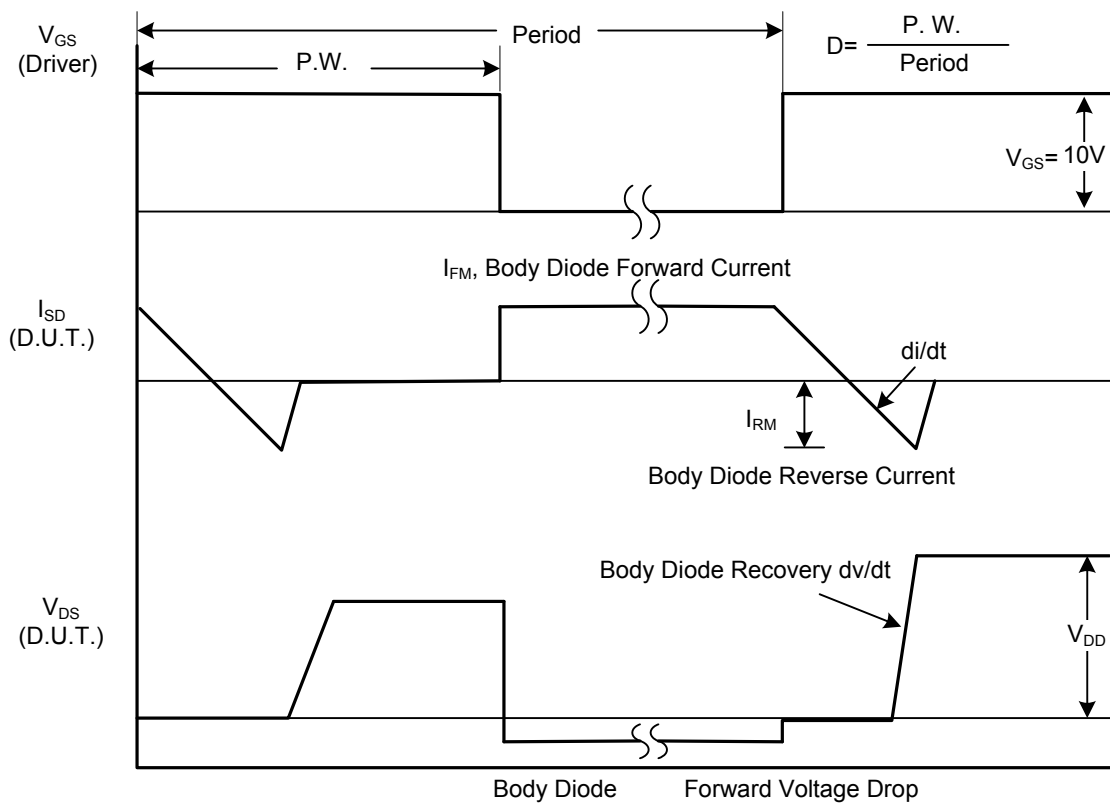

Peak Diode Recovery dv/dt Waveforms

TEST CIRCUITS AND WAVEFORMS (Cont.)

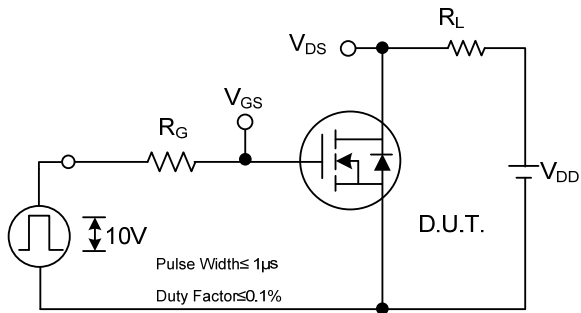

Switching Test Circuit

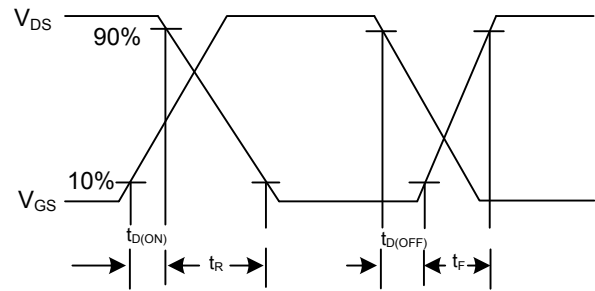

Switching Waveforms

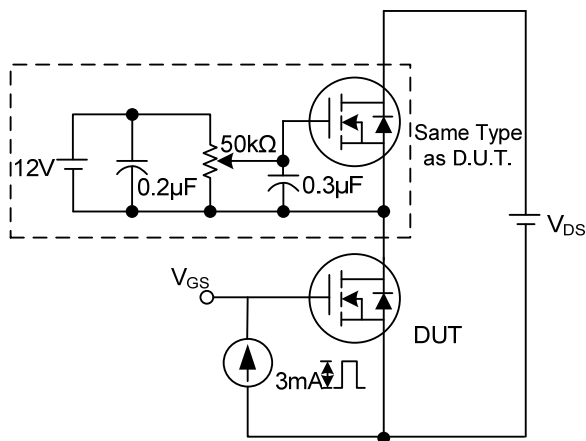

Gate Charge Test Circuit

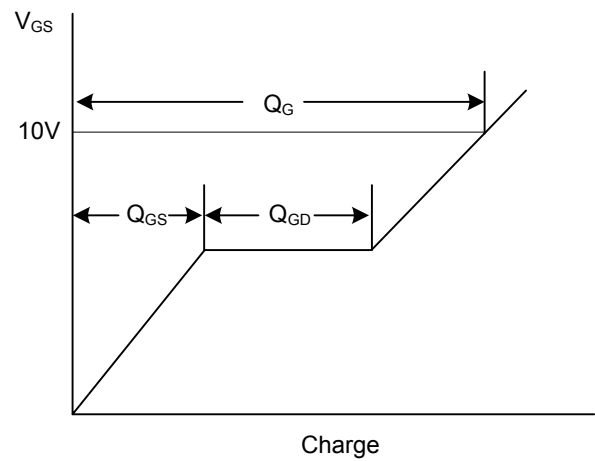

Gate Charge Waveform

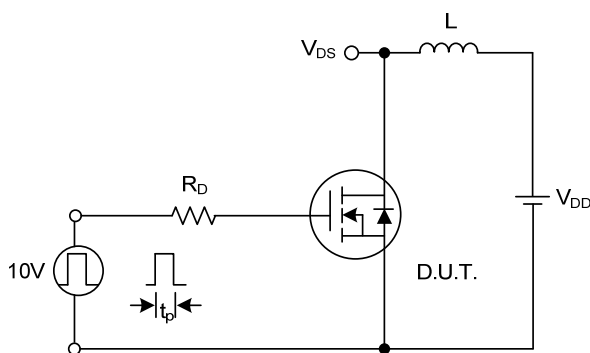

Unclamped Inductive Switching Test Circuit

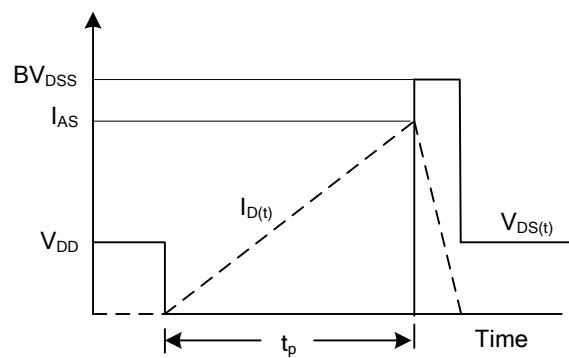

Unclamped Inductive Switching Waveforms

TYPICAL CHARACTERISTICS

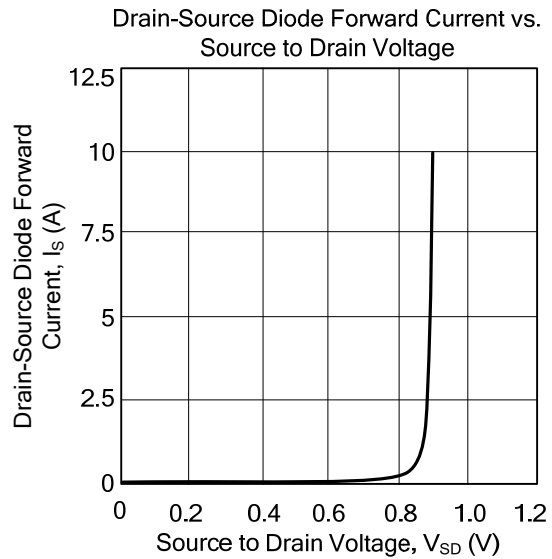
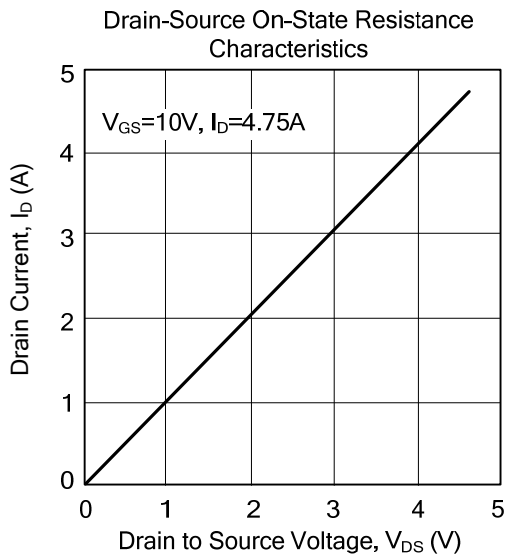
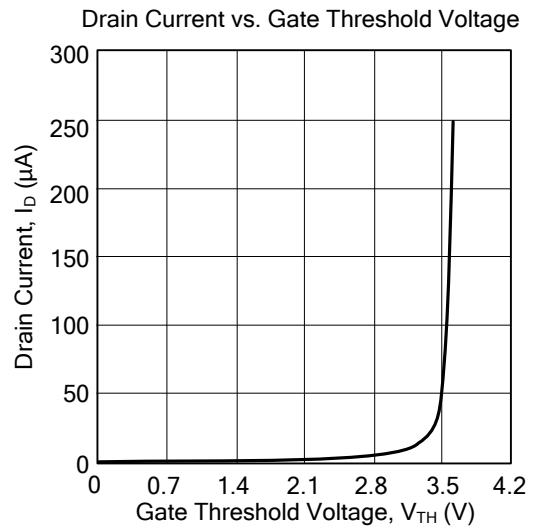
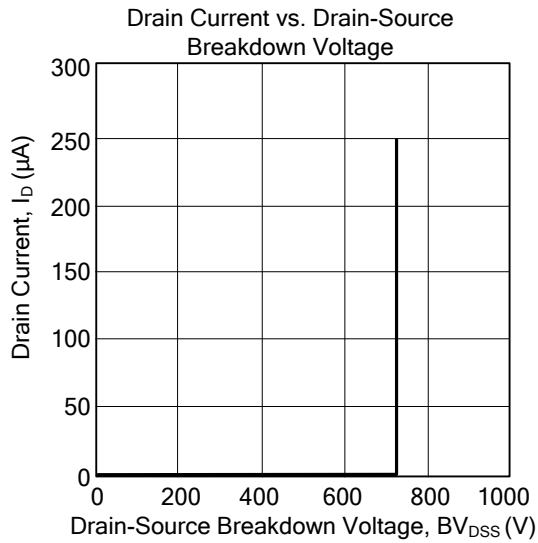

UTC assumes no responsibility for equipment failures that result from using products at values that exceed, even momentarily, rated values (such as maximum ratings, operating condition ranges, or other parameters) listed in products specifications of any and all UTC products described or contained herein. UTC products are not designed for use in life support appliances, devices or systems where malfunction of these products can be reasonably expected to result in personal injury. Reproduction in whole or in part is prohibited without the prior written consent of the copyright owner. The information presented in this document does not form part of any quotation or contract, is believed to be accurate and reliable and may be changed without notice.