

GENERAL DESCRIPTION

The HP4054 is a complete constant-current/ constant voltage linear charger for single cell Lithium-Ion batteries. No external sense resistor is needed, and no blocking diode is required due to the internal MOSFET architecture. The charge voltage is fixed at 4.2V or 4.35V, and the charge current can be programmed externally with a single resistor.

The HP4054 automatically terminates the charge cycle when the charge current drops to 1/10 the programmed value after the final float voltage is reached.

When the input supply (wall adapter or USB supply) is removed, the HP4054 automatically enters a low current state, dropping the battery drain current to less than 0.1uA.

The HP4054 is available in a small package with SOT23-5L. Standard product is Pb-Free.

FEATURES

- Programmable Charge Current Up to 500mA
- Under Voltage Lockout Protection
- 150mV(Typ.) Automatic Recharge Threshold
- Charge Status Output Pin
- 2.9V Trickle Charge Threshold
- Soft-Start Limits Inrush Current

APPLICATIONS

- Feature Phone
- MP3/MP4 Players
- Electric Toy
- Bluetooth, wireless handsets
- Others portable electronic device

MARKING DESCRIPTION

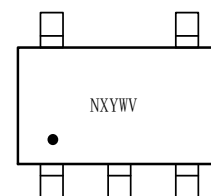

“N”: Product code, here use “M” stand for “HP4054”

“X”: Internal Control Code

“Y”: Internal Control Code

“W”: The week of manufacturing. “A”stands for week

1, “Z”stands for week 26, “a”stands for week

27, “z” stands for week 52.

“V”: Product version.

TYPICAL APPLICATION CIRCUIT

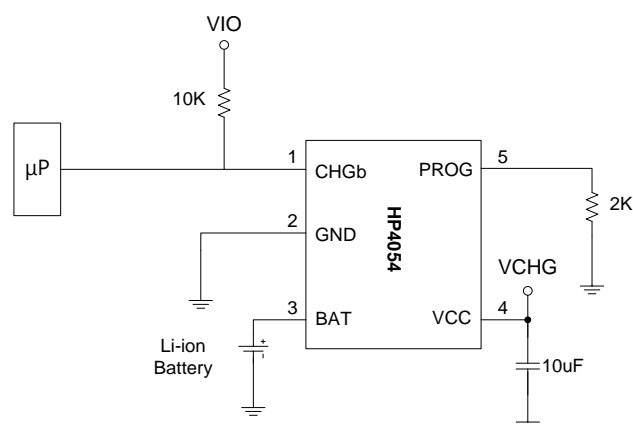
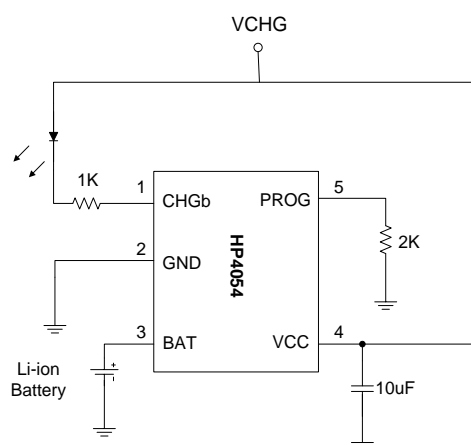

ORDERING INFORMATION

Part No.	V _{FLOAT}	Package	Temperature	Tape & Reel
HP4054S5-42	4.2V	SOT23-5L	-40 ~ 85°C	3000/Reel
HP4054S5-435	4.35V	SOT23-5L	-40 ~ 85°C	3000/Reel

PART NUMBER RULES

HP4054 [1] - [2]

Code	Description
[1]	Package: S5: SOT23-5L
[2]	Voltage version: 42: 4.2V 435: 4.35V

PIN ASSIGNMENT



SOT23-5L

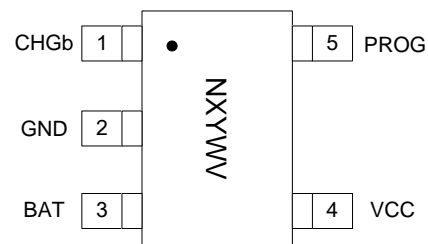

HP4054 (Top view)

PIN DESCRIPTION:

Pin Number	Pin Name	I/O	Function
1	CHGb	O	Open-Drain Charge Status Output. When the battery is charging, the CHGb pin is pulled low. When the charge cycle is completed or VCC is removed, the CHGb is forced high impedance.
2	GND	Ground	Power ground
3	BAT	O	Charge Current Output. Provides charge current to the battery and regulates the final float voltage to 4.2V or 4.35V.
4	VCC	Power	Power Supply
5	PROG	O	Charge current setting, charge current monitor and shut down pin. The charging current is given by $I_{BAT} = 1000/R_{PROG}(A)$. Please choose 1% precision resistor for R_{PROG} . The chip will be shutdown when PROG pin floating.

ABSOLUTE MAXIMUM RATINGS (Note)

SYMBOL	ITEMS	VALUE	UNIT
V_{CC}	Input Voltage	-0.3 ~ 8	V
V_{PROG}	PROG Voltage	-0.3 ~ $V_{CC}+0.3$	V
V_{BAT}	BAT Voltage	-0.3 ~ 7	V
V_{CHGb}	CHGb Voltage	-0.3 ~ 10	V
P_{D_MAX}	Power Dissipation	SOT23-5L	0.8
T_J	Junction Temperature	-40 ~ 125	°C
T_{STG}	Storage Temperature	-55 ~ 150	°C
T_{SOLDER}	Package Lead Soldering Temperature	260°C, 10s	

Note: Exceed these limits to damage to the device. Exposure to absolute maximum rating conditions may affect device reliability.

RECOMMENDED OPERATING CONDITION

		MIN	NOM	MAX	UNIT
V_{CC}	Input operating voltage range	4	5	6	V
I_{BAT}	Battery charge current range	100	250	500	mA
T_J	Junction temperature	0		125	°C
R_{PROG}	CC mode charge current programming resistor	2	4	10	KΩ

SIMPLIFIED BLOCK DIAGRAM

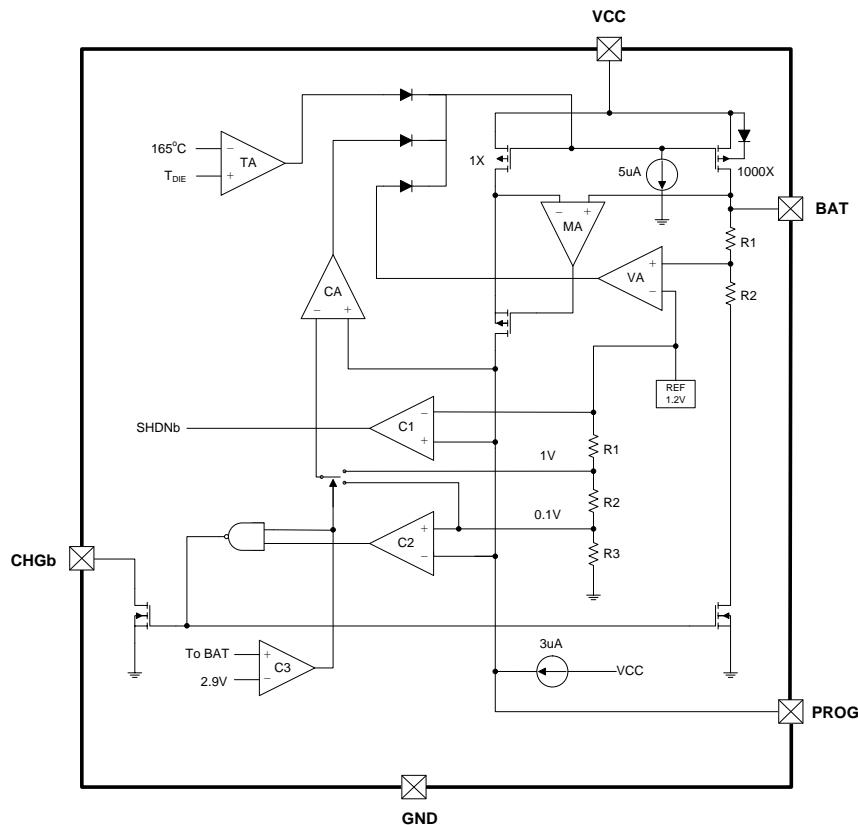

ELECTRICAL CHARACTERISTICS

The following specifications apply for $V_{CC}=5V$, $T_A=25^{\circ}C$, unless specified otherwise.

SYMBOL	ITEMS	CONDITIONS	MIN	TYP	MAX	UNIT
V_{CC}	Supply Voltage		4	5	6	V
$I_{SPLYCHRG}$	Charge Mode GND Current	$R_{PROG}=2k\Omega$, $V_{CC}=5V$		160		μA
$I_{BATCHRG}$	Charge Mode Battery Current	$R_{PROG}=2k\Omega$	450	500	550	mA
		$R_{PROG}=4k\Omega$	225	250	275	mA
$V_{PROGCHRG}$	PROG Pin Voltage	$R_{PROG}=2k\Omega$	0.9	1	1.1	V
		$R_{PROG}=4k\Omega$	0.9	1	1.1	V
$I_{SPLYSTBY}$	Standby Mode Supply Current	Charge Terminated		130		μA
$I_{BATSTBY}$	Standby Mode Battery Current	Charge Terminated		3		μA
$I_{SPLYASD}$	Shutdown Mode Supply Current	$V_{CC}<V_{BAT}$		36		μA
I_{BATASD}	Shutdown Mode BAT Pin Current	$V_{CC}<V_{BAT}$		0.5	1	μA
$I_{BATSLEEP1}$	Sleep Mode BAT Pin Current	$V_{CC}=0V$, $V_{BAT}=5V$		0.02	0.1	μA
$I_{BATSLEEP2}$	Sleep Mode BAT Pin Current	V_{CC} floating, $V_{BAT}=5V$		0.02	0.1	μA
V_{FLOAT}	Float Voltage	Charge Terminated	4.158	4.2	4.242	V
			4.306	4.35	4.394	V
I_{TRIKL}	Trickle and Terminal Charge Current	$V_{BAT} < V_{TRIKL}$, $R_{PROG}=2k\Omega$	30	50	70	mA
V_{TRIKL}	Trickle Charge Voltage Threshold	V_{BAT} from low to high	2.8	2.9	3	V
$V_{TRIKL, HYS}$	Trickle Charge Voltage Hysteresis	V_{BAT} from high to low		200		mV
V_{UVLO}	UVLO Threshold	V_{CC} from low to high	3.5	3.7	3.9	V
$V_{UVLO, HYS}$	UVLO Hysteresis	V_{CC} from high to low		260		mV
V_{ASD}	$V_{CC}-V_{BAT}$ Lockout Threshold Voltage	V_{CC} from high to low		70		mV
		V_{CC} from low to high		300		mV
ΔV_{RECHRG}	Auto Recharge Battery Voltage	$V_{FLOAT} - V_{RECHRG}$	100	150	200	mV
V_{CHGb}	CHGb Pin Output Low Voltage	$I_{CHGb}=5mA$		0.3	0.6	V
R_{ON}	Power FET ON Resistance	$R_{PROG}=2k\Omega$, $V_{CC}=4.2V$		0.37		Ω
T_{SS}	Soft-Start Time			100		us
T_{RECHRG}	Recharge Comparator Filter Time			2		ms
T_{TERM}	Charge Terminated Filter Time			1	2	ms

TYPICAL CHARACTERISTICS

V_{PROG} vs. Input Voltage

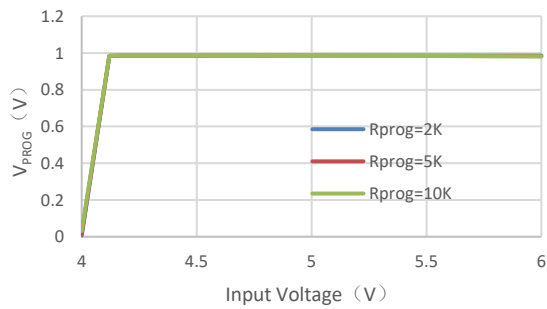

V_{PROG} vs. Temperature

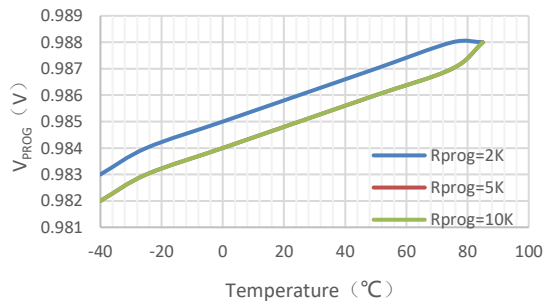

Charge Current vs. Input Voltage

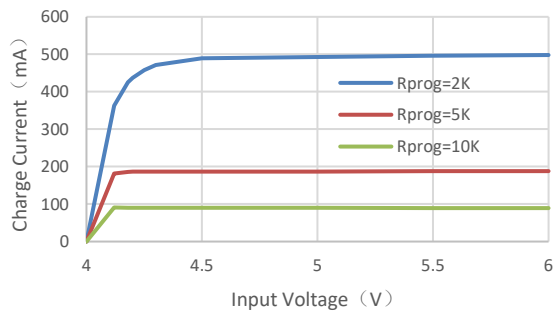

Charge Current vs. V_{PROG}

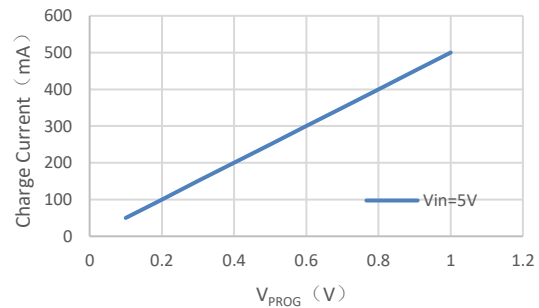

Charge Current vs. Battery Voltage

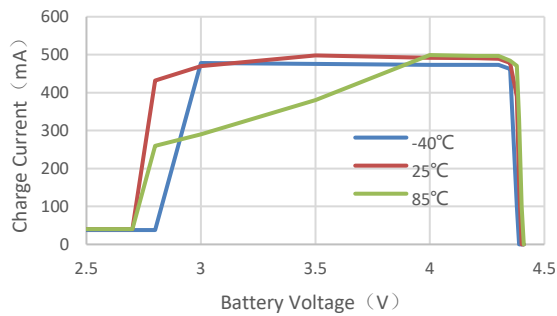

Charge Current vs. Temperature

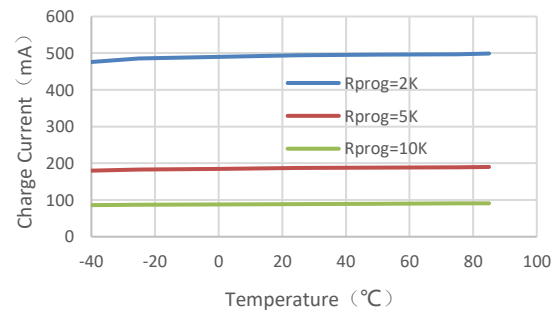

Trickle Current vs. Input Voltage

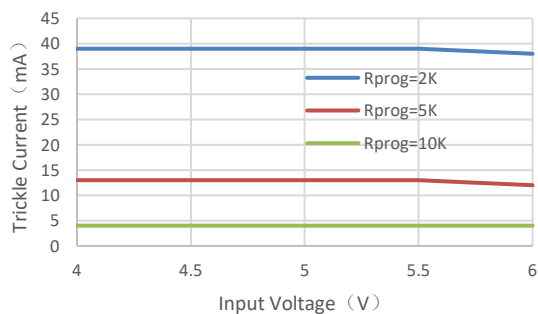

Trickle Current vs. Temperature

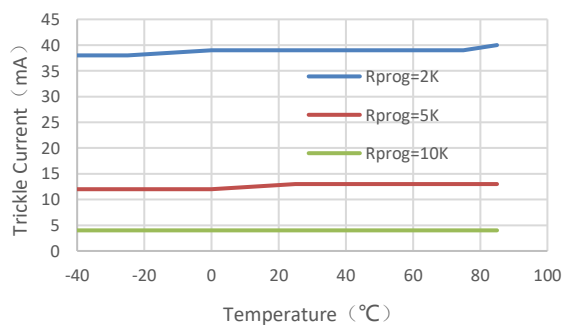

Trickle Voltage vs. Temperature

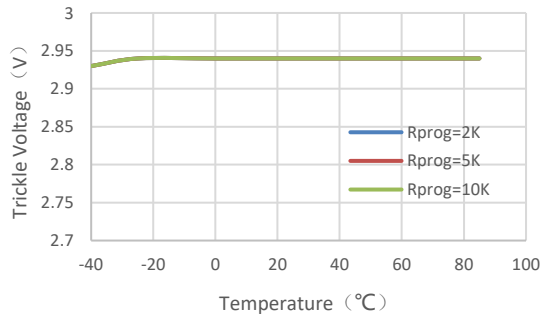

Trickle Voltage vs. Input Voltage

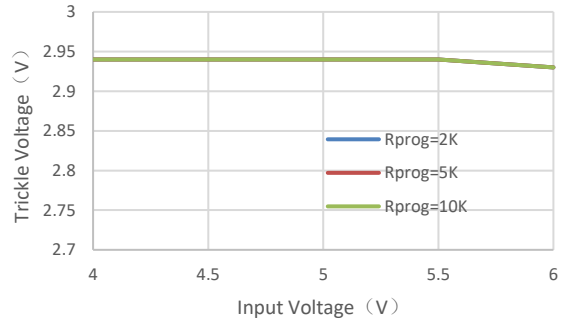

Float Voltage vs. Input Voltage

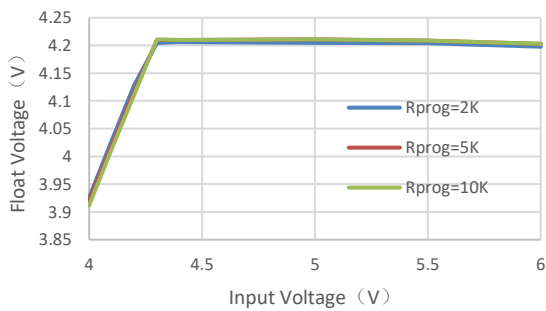

Float Voltage vs. Temperature

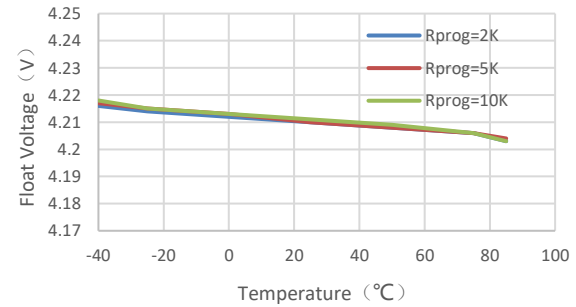

Float Voltage vs. Input Voltage

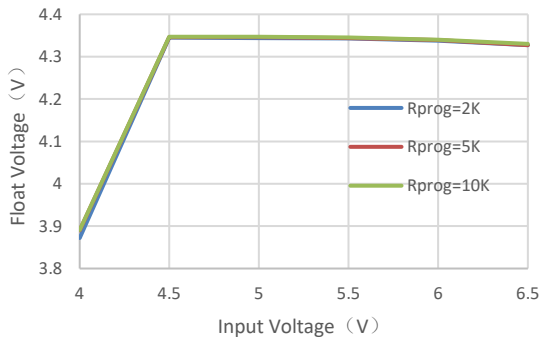

Float Voltage vs. Temperature

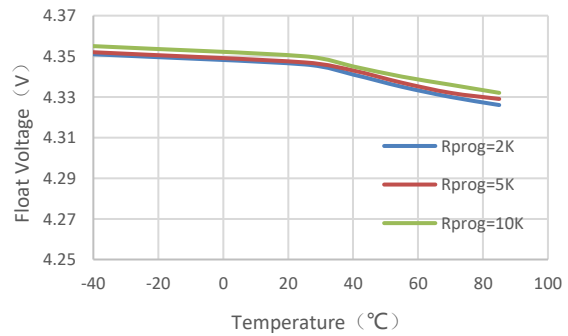

Vrecharge vs. Temperature

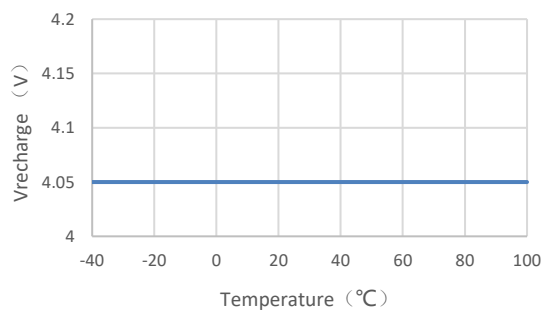

CHGb Current vs. CHGb Voltage

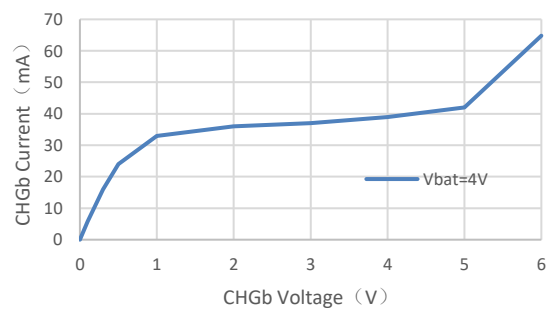

Ron vs. Temperature

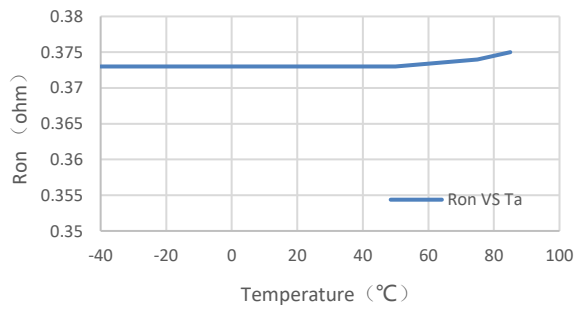

Charging Curve

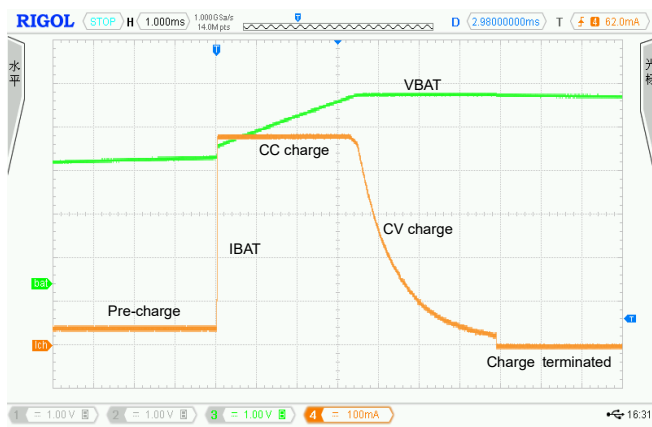

OPERATION INFORMATION

The HP4054 is a single battery Li-Ion battery charger using a constant-current / constant-voltage algorithm. It can deliver up to 0.5A of charge current (using a good thermal PCB layout) with a final float voltage accuracy of $\pm 1\%$. The HP4054 includes an internal P-channel power MOSFET and thermal regulation circuitry. No blocking diode or external current sense resistor is required, thus the basic charger circuit requires only two external components. Furthermore, the HP4054 is capable of operating from a USB power source.

Normal charge cycle

A charge cycle begins when the voltage at the VCC pin rises above the UVLO threshold level and a 1% program resistor is connected from the PROG pin to ground or when a battery is connected to the charger output. If the BAT pin is less than 3.0V, the charger enters trickle charge mode. In this mode, the HP4054 supplies approximately 1/10 the programmed charge current to bring the battery voltage up to a safe level for full current charging.

When the BAT pin voltage rises above 3.0V, the charger enters constant-current mode, where the programmed charge current is supplied to the battery. When the BAT pin approaches the final float voltage, the HP4054 enters constant-voltage mode and the charge current begins to decrease. The charge cycle ends when the PROG voltage is less than 100mV.

Programming charge current

The charge current is programmed using a single resistor from the PROG pin to ground. The battery charge current of constant current mode is 1000 times the current out of the PROG pin. The program resistor and the charge current of constant current are calculated using the following equations:

$$I_{\text{CHG}} = 1000 / R_{\text{PROG}} \text{ (A)}$$

Please choose 1% precision resistor for RPROG, this will effect the accuracy of CC charge current and termination current.

Charge termination

A charge cycle is terminated when the charge current falls to 1/10 of the programmed value after the final float voltage is reached. This condition is detected by using an internal, filtered comparator to monitor the PROG pin. When the PROG pin voltage falls below 100mV for longer than T_{TERM} (typically 1ms), charging is terminated. The charge current is latched off and the HP4054 enters standby mode, where the input supply current drops to 130uA. **(Note: 1/10 CC termination is disabled in trickle charging mode and thermal limiting modes).**

When charging, transient loads on the BAT pin can cause the PROG pin to fall below 100mV for short periods of time before the DC charge current has dropped to 1/10 of the programmed value. The 1ms filter time (T_{TERM}) on the termination comparator ensures that transient loads of this nature do not result in premature charge cycle termination. Once the average charge current drops below 1/10 of the programmed value, the HP4054 terminates the charge cycle and ceases to provide any current through the BAT pin, the chip will be put into standby mode. In this state, all loads on the BAT pin must be supplied by the battery.

The HP4054 constantly monitors the BAT pin voltage in standby mode. If this voltage drops below the 4.05V recharge threshold (V_{RECHRG}), another charge cycle begins and current is once again supplied to the battery. The state diagram of a typical charge cycle is as below:

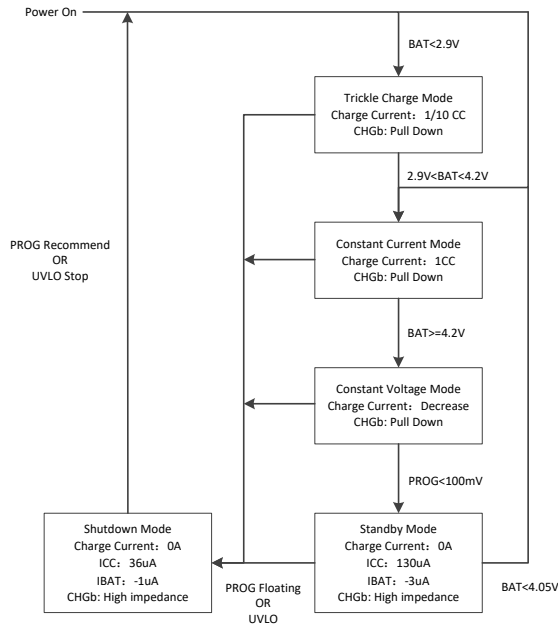

Charge status indicator (CHGb)

The charge status output indicator is an open drain circuit. The indicator has two different states: pull-down (~30mA), and high impedance. The pull-down state indicates that the HP4054 is in a charge cycle. High impedance indicates that the charge cycle is complete. The CHGb also can be used to detect the charge states by a microprocessor with a pull-up resistor.

Shutdown mode

At any point in the charge cycle, the HP4054 can be put into shutdown mode by removing PROG thus floating the PROG pin. This reduces the battery drain current to less than 0.5uA and the supply current to

less than 36uA. A new charge cycle can be initiated by reconnecting the program resistor. Below is a recommend application.

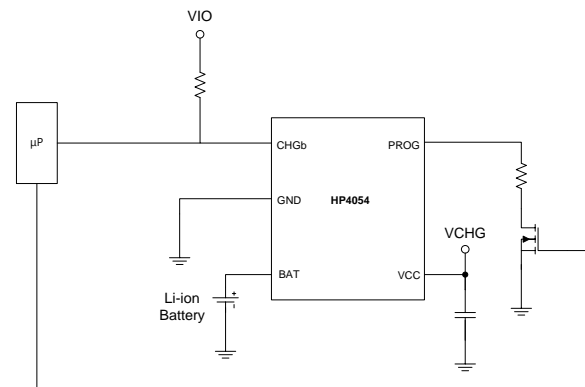

The HP4054 also be put into shutdown mode when VCC voltage down to UVLO threshold. In this state, the CHGb pin is high impedance state. The CHGb pin is also in a high impedance state if the charge cycle is completed.

Automatic recharge

Once the charge cycle is terminated, the HP4054 continuously monitors the voltage on the BAT pin using a comparator with a 2ms filter time (T_{RECHRG}). A charge cycle restarts when the battery voltage falls below 4.05V (which corresponds to approximately 80% to 90% battery capacity). This ensures that the battery is kept at or near a fully charged condition and eliminates the need for periodic charge cycle initiations. CHGb output enters a pull-down state during recharge cycles.

APPLICATION INFORMATIONS

Stability considerations

The constant-voltage mode feedback loop is stable without an output capacitor provided a battery is connected to the charge output. With no battery present, an output capacitor is recommended to reduce ripple voltage. When using high value, low ESR ceramic capacitors, it is recommended to add a 1Ω resistor in series with the capacitor. No series resistor is needed if tantalum capacitors are used.

In constant-current mode, the PROG pin is in the feedback loop, not the battery. The constant-current mode stability is affected by the impedance at the PROG pin. With no additional capacitance on the PROG pin, the charger is stable with program resistor values as high as 50KΩ. However, additional capacitance on this node reduces the maximum allowed program resistor thus it should be avoided.

Thermal limit

An internal thermal feedback loop reduces the programmed charge current if the die temperature attempts to rise above a preset value of approximately 160 °C . This feature protects the HP4054 from excessive temperature and allows the user to push the limits of the power handling capability of a given circuit board without risk of damaging the HP4054. The charge current can be set according to typical (not worst-case) ambient temperature with the assurance that the charger will automatically reduce the current in worse-case conditions.

Power dissipation

The conditions that cause the HP4054 to reduce charge current through thermal feed-back can be approximated by considering the power dissipated in the IC. Nearly all of this power dissipation is generated by the internal MOSFET. This is calculated to be approximately:

$$P_D = (V_{CC} - V_{BAT}) * I_{BAT}$$

It is important to remember that HP4054 applications do not be designed for worst-case thermal conditions since the IC will automatically reduce power dissipation when the junction temperature reaches approximately 160°C (Constant temperature mode).

VCC bypass capacitor

Many types of capacitors can be used for input bypass, however, caution must be exercised when using multilayer ceramic capacitors. Because of the self-resonant and high Q characteristics of some types of ceramic capacitors, a 10uF/16V ceramic capacitor is recommended for this bypass capacitor. Due to a high voltage transient will be generated under some start-up conditions, such as connecting the charger input to a live power source.

Charge current soft-start

The HP4054 includes a soft-start circuit to minimize the inrush current at the start of a charge cycle. When a charge cycle is initiated, the charge current ramps from zero to the full-scale current over a period of approximately 100us. This has the effect of minimizing the transient current load on the power supply during start-up.

PACKAGE OUTLINE

Package	SOT23-5L	Devices per reel	3000Pcs	Unit	mm
Package Dimension:					
Symbol	Dimensions In Millimeters		Dimensions In Inches		
	Min	Max	Min	Max	
A	1.050	1.250	0.041	0.049	
A1	0.000	0.100	0.000	0.004	
A2	1.050	1.150	0.041	0.045	
b	0.300	0.500	0.012	0.020	
c	0.100	0.200	0.004	0.008	
D	2.820	3.020	0.111	0.119	
E	1.500	1.700	0.059	0.067	
E1	2.650	2.950	0.104	0.116	
e	0.950(BSC)		0.037(BSC)		
e1	1.800	2.000	0.071	0.079	
L	0.300	0.600	0.012	0.024	
θ	0°C	8°C	0°C	8°C	

REVISION HISTORY

Version No.	Date	Description
Preliminary	2017-06-05	- Initial preliminary release
Version 0.1	2018-05-28	- Update typical performance characteristics
Version 1.0	2019-12-02	- Update marking description