



Reference Specification

DEB Series

Lead Type Disc Ceramic Capacitors of Class 2 for General Purpose

Product specifications in this catalog are as of Dec. 2017, and are subject to change or obsolescence without notice.

Please consult the approval sheet before ordering. Please read rating and Cautions first.

Reference only

⚠ CAUTION

1. OPERATING VOLTAGE

When DC-rated capacitors are to be used in AC or ripple current circuits, be sure to maintain the V_{p-p} value of the applied voltage or the V_{o-p} which contains DC bias within the rated voltage range.

When the voltage is started to apply to the circuit or it is stopped applying, the irregular voltage may be generated for a transit period because of resonance or switching. Be sure to use a capacitor within rated voltage containing these irregular voltage.

When DC-rated capacitors are to be used in input circuits from commercial power source (AC filter), be sure to use Safety Recognized Capacitors because various regulations on withstand voltage or impulse withstand established for each equipment should be taken into considerations.

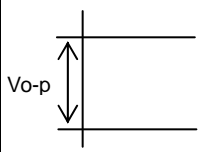
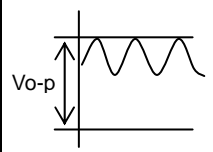
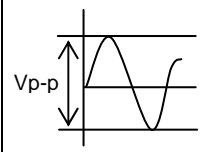
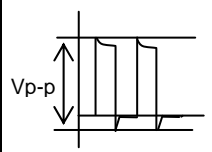
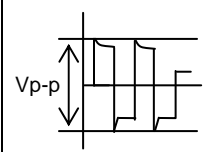
Voltage	DC Voltage	DC+AC Voltage	AC Voltage	Pulse Voltage(1)	Pulse Voltage(2)
Positional Measurement					

2. OPERATING TEMPERATURE AND SELF-GENERATED HEAT

Keep the surface temperature of a capacitor below the upper limit of its rated operating temperature range. Be sure to take into account the heat generated by the capacitor itself.

When the capacitor is used in a high-frequency current, pulse current or the like, it may have the self-generated heat due to dielectric-loss. The allowable frequency should be in less than 300kHz in sine wave. Applied voltage should be the load such as self-generated heat is within 20 °C on the condition of atmosphere temperature 25 °C. When measuring, use a thermocouple of small thermal capacity-K of $\phi 0.1\text{mm}$ and be in the condition where capacitor is not affected by radiant heat of other components and wind of surroundings. While, in case of non-sine wave which include a harmonic frequency, please contact our sales representatives or product engineers.

3. FAIL-SAFE

When capacitor would be broken, failure may result in a short circuit. Be sure to provide an appropriate fail-safe function like a fuse on your product if failure would follow an electric shock, fire or fume.

4. VIBRATION AND IMPACT

Do not expose a capacitor or its leads to excessive shock or vibration during use.

5. SOLDERING

When soldering this product to a PCB/PWB, do not exceed the solder heat resistance specification of the capacitor. Subjecting this product to excessive heating could melt the internal junction solder and may result in thermal shocks that can crack the ceramic element.

When soldering capacitor with a soldering iron, it should be performed in following conditions.

Temperature of iron tip : 400 °C max.

Soldering iron wattage : 50W max.

Soldering time : 3.5 s max.

Reference only

6. BONDING, RESIN MOLDING AND COATING

In case of bonding, molding or coating this product, verify that these processes do not affect the quality of capacitor by testing the performance of the bonded, molded or coated product in the intended equipment.

In case of the amount of applications, dryness / hardening conditions of adhesives and molding resins containing organic solvents (ethyl acetate, methyl ethyl ketone, toluene, etc.) are unsuitable, the outer coating resin of a capacitor is damaged by the organic solvents and it may result, worst case, in a short circuit.

The variation in thickness of adhesive, molding resin or coating may cause a outer coating resin cracking and/or ceramic element cracking of a capacitor in a temperature cycling.

7. TREATMENT AFTER BONDING, RESIN MOLDING AND COATING

When the outer coating is hot (over 100 °C) after soldering, it becomes soft and fragile.

So please be careful not to give it mechanical stress.

Failure to follow the above cautions may result, worst case, in a short circuit and cause fuming or partial dispersion when the product is used.

8. OPERATING AND STORAGE ENVIRONMENT

The insulating coating of capacitors does not form a perfect seal; therefore, do not use or store capacitors

in a corrosive atmosphere, especially where chloride gas, sulfide gas, acid, alkali, salt or the like are present. And avoid exposure to moisture. Before cleaning, bonding, or molding this product, verify that these processes do not affect product quality by testing the performance of a cleaned, bonded or molded product in the intended equipment. Store the capacitors where the temperature and relative humidity do not exceed -10 to 40 °C and 15 to 85%. Use capacitors within 6 months after delivered.

Check the solderability after 6 months or more.

9. LIMITATION OF APPLICATIONS

Please contact us before using our products for the applications listed below which require especially high reliability for the prevention of defects which might directly cause damage to the third party's life, body or property.

1. Aircraft equipment
2. Aerospace equipment
3. Undersea equipment
4. Power plant control equipment
5. Medical equipment
6. Transportation equipment (vehicles, trains, ships, etc.)
7. Traffic signal equipment
8. Disaster prevention / crime prevention equipment
9. Data-processing equipment exerting influence on public
10. Application of similar complexity and/or reliability requirements to the applications listed in the above.

NOTICE

1. CLEANING (ULTRASONIC CLEANING)

To perform ultrasonic cleaning, observe the following conditions.

Rinse bath capacity : Output of 20 watts per liter or less.

Rinsing time : 5 min maximum.

Do not vibrate the PCB/PWB directly.

Excessive ultrasonic cleaning may lead to fatigue destruction of the lead wires.

2. CAPACITANCE CHANGE OF CAPACITORS

- Class 1 capacitors

Capacitance might change a little depending on a surrounding temperature or an applied voltage.

Please contact us if you use for the strict time constant circuit.

- Class 2 and 3 capacitors

Class 2 and 3 capacitors like temperature characteristic B, E and F have an aging characteristic, whereby the capacitor continually decreases its capacitance slightly if the capacitor leaves for a long time. Moreover, capacitance might change greatly depending on a surrounding temperature or an applied voltage. So, it is not likely to be able to use for the time constant circuit.

Please contact us if you need a detail information.

⚠ NOTE

1. Please make sure that your product has been evaluated in view of your specifications with our product being mounted to your product.

2. You are requested not to use our product deviating from this specification.

Reference only

1. Application

This specification is applied to Lead Type Disc Ceramic Capacitors of D1kV ratings and Class 2 of DEB series used for General Electric equipment.

Do not use these products in any automotive power train or safety equipment including battery chargers for electric vehicles and plug-in hybrids.

2. Rating

2-1. Operating temperature range

-25 ~ +85°C

2-2. Part number configuration

ex.) DEB B3 3A 332 K A2 B _____
 Series Temperature Rated Capacitance Capacitance Lead Packing Individual
 characteristic voltage tolerance code style code specification

- Temperature characteristic

Code	Temperature characteristic
B3	B
E3	E
F3	F

Please confirm detailed specification on [Specification and test methods].

- Rated voltage

Code	Rated voltage
3A	DC1kV

- Capacitance

The first two digits denote significant figures ; the last digit denotes the multiplier of 10 in pF.

ex.) In case of 332.

$$33 \times 10^2 = 3300 \text{pF}$$

- Capacitance tolerance

Please refer to [Part number list].

- Lead code

Code	Lead style
A*	Vertical crimp long type
C*	Straight long type
B*	Vertical crimp short type
D*	Straight short type
N*	Vertical crimp taping type
P*	Straight taping type

* Please refer to [Part number list].

Solder coated copper wire is applied for termination.

Reference only

- Packing style code

Code	Packing type
B	Bulk type
A	Ammo pack taping type

- Individual specification

In case part number cannot be identified without 'individual specification', it is added at the end of part number.

3. Marking

Temperature characteristic : Letter code

Identified by code for char. B or char. E.

(Omitted for maximum body diameter ϕ 9mm and under)

Nominal capacitance : 3 digit system

Capacitance tolerance : Code(Omitted for maximum body diameter ϕ 6mm and under)

Rated voltage : Letter code

Company name code : Abbreviation 

(Omitted for maximum body diameter ϕ 9mm and under)

Manufacturing year : Letter code(The last digit of A.D. year.)

(Omitted for maximum body diameter ϕ 5mm and under)

Manufacturing month : Code(Omitted for maximum body diameter ϕ 5mm and under)

Feb./Mar. → 2	Aug./Sep. → 8
Apr./May → 4	Oct./Nov. → O
Jun./Jul. → 6	Dec./Jan. → D

(Example)

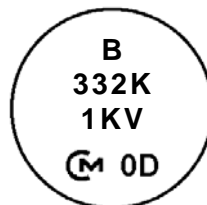

Reference only

4. Part number list

-Straight long type
(Lead code:C*)

-Vertical crimp long type
(Lead code:A*)

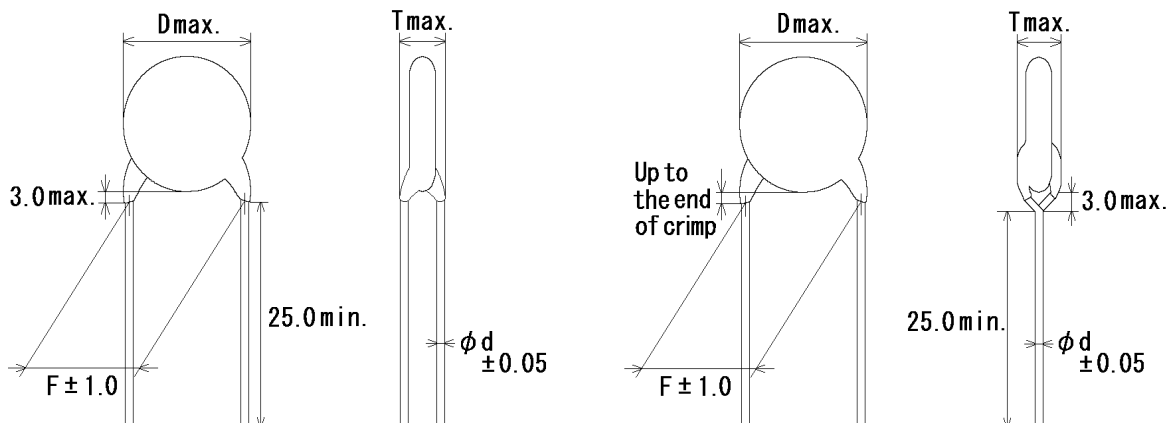

Note) The mark '*' of lead code differ from lead spacing(F) and lead diameter(d).
Please see the following list about details.

Unit : mm

T.C.	Cap. (pF)	Cap. tol.	Customer Part Number	Murata Part Number	DC Rated Volt. (V)	Dimension (mm)				Lead Code	Pack qty. (pcs)
						D	T	F	d		
B	100	±10%		DEBB33A101KC1B	1000	4.5	4.0	5.0	0.5	C1	500
B	150	±10%		DEBB33A151KC1B	1000	4.5	4.0	5.0	0.5	C1	500
B	220	±10%		DEBB33A221KC1B	1000	4.5	4.0	5.0	0.5	C1	500
B	330	±10%		DEBB33A331KC1B	1000	4.5	4.0	5.0	0.5	C1	500
B	470	±10%		DEBB33A471KC1B	1000	5.0	4.0	5.0	0.5	C1	500
B	680	±10%		DEBB33A681KA2B	1000	6.0	4.0	5.0	0.6	A2	500
B	1000	±10%		DEBB33A102KA2B	1000	6.0	4.0	5.0	0.6	A2	500
B	1500	±10%		DEBB33A152KA2B	1000	8.0	4.0	5.0	0.6	A2	250
B	2200	±10%		DEBB33A222KA2B	1000	9.0	4.0	5.0	0.6	A2	250
B	3300	±10%		DEBB33A332KA2B	1000	10.0	4.0	5.0	0.6	A2	250
B	4700	±10%		DEBB33A472KA3B	1000	12.0	4.0	7.5	0.6	A3	200
B	6800	±10%		DEBB33A682KA3B	1000	15.0	4.0	7.5	0.6	A3	100
E	1000	+80/-20%		DEBE33A102ZC1B	1000	5.0	4.0	5.0	0.5	C1	500
E	2200	+80/-20%		DEBE33A222ZA2B	1000	7.0	4.0	5.0	0.6	A2	500
E	4700	+80/-20%		DEBE33A472ZA2B	1000	9.0	4.0	5.0	0.6	A2	250
E	10000	+80/-20%		DEBE33A103ZA3B	1000	13.0	4.0	7.5	0.6	A3	200
F	2200	+80/-20%		DEBF33A222ZA2B	1000	6.0	4.0	5.0	0.6	A2	500
F	4700	+80/-20%		DEBF33A472ZA2B	1000	7.0	4.0	5.0	0.6	A2	500
F	10000	+80/-20%		DEBF33A103ZA2B	1000	10.0	4.0	5.0	0.6	A2	250

Reference only

·Straight short type
(Lead code:D*)

·Vertical crimp short type
(Lead code:B*)

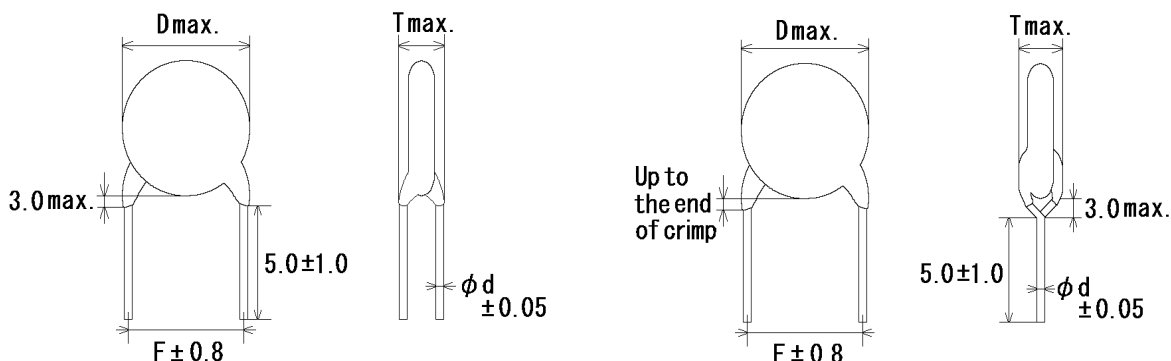

Note) The mark '*' of lead code differ from lead spacing(F) and lead diameter(d).
Please see the following list about details.

Unit : mm

T.C.	Cap. (pF)	Cap. tol.	Customer Part Number	Murata Part Number	DC Rated Volt. (V)	Dimension (mm)				Lead Code	Pack qty. (pcs)
						D	T	F	d		
B	100	±10%		DEBB33A101KD1B	1000	4.5	4.0	5.0	0.5	D1	500
B	150	±10%		DEBB33A151KD1B	1000	4.5	4.0	5.0	0.5	D1	500
B	220	±10%		DEBB33A221KD1B	1000	4.5	4.0	5.0	0.5	D1	500
B	330	±10%		DEBB33A331KD1B	1000	4.5	4.0	5.0	0.5	D1	500
B	470	±10%		DEBB33A471KD1B	1000	5.0	4.0	5.0	0.5	D1	500
B	680	±10%		DEBB33A681KB2B	1000	6.0	4.0	5.0	0.6	B2	500
B	1000	±10%		DEBB33A102KB2B	1000	6.0	4.0	5.0	0.6	B2	500
B	1500	±10%		DEBB33A152KB2B	1000	8.0	4.0	5.0	0.6	B2	500
B	2200	±10%		DEBB33A222KB2B	1000	9.0	4.0	5.0	0.6	B2	500
B	3300	±10%		DEBB33A332KB2B	1000	10.0	4.0	5.0	0.6	B2	500
B	4700	±10%		DEBB33A472KB3B	1000	12.0	4.0	7.5	0.6	B3	250
B	6800	±10%		DEBB33A682KB3B	1000	15.0	4.0	7.5	0.6	B3	200
E	1000	+80/-20%		DEBE33A102ZD1B	1000	5.0	4.0	5.0	0.5	D1	500
E	2200	+80/-20%		DEBE33A222ZB2B	1000	7.0	4.0	5.0	0.6	B2	500
E	4700	+80/-20%		DEBE33A472ZB2B	1000	9.0	4.0	5.0	0.6	B2	500
E	10000	+80/-20%		DEBE33A103ZB3B	1000	13.0	4.0	7.5	0.6	B3	250
F	2200	+80/-20%		DEBF33A222ZB2B	1000	6.0	4.0	5.0	0.6	B2	500
F	4700	+80/-20%		DEBF33A472ZB2B	1000	7.0	4.0	5.0	0.6	B2	500
F	10000	+80/-20%		DEBF33A103ZB2B	1000	10.0	4.0	5.0	0.6	B2	500

Reference only

·Straight taping type
(Lead code:P*)

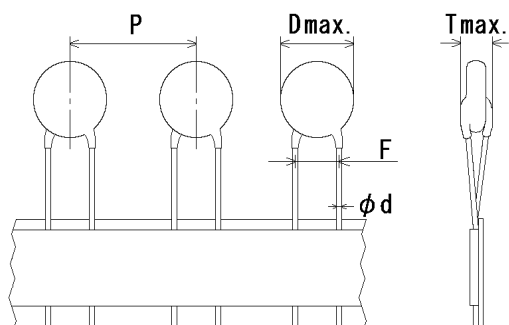

·Vertical crimp taping type
(Lead code:N*)

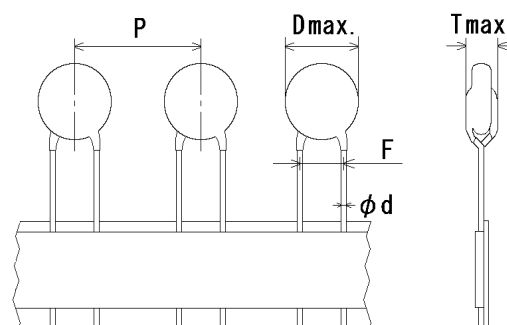

Note) The mark '*' of lead code differ from lead spacing(F), lead diameter(d) and pitch of component(P). Please see the following list or taping specification about details.

Unit : mm

T.C.	Cap. (pF)	Cap. tol.	Customer Part Number	Murata Part Number	DC Rated volt. (V)	Dimension (mm)					Lead code	Pack qty. (pcs)
						D	T	F	d	P		
B	100	±10%		DEBB33A101KP2A	1000	4.5	4.0	5.0	0.6	12.7	P2	1500
B	150	±10%		DEBB33A151KP2A	1000	4.5	4.0	5.0	0.6	12.7	P2	1500
B	220	±10%		DEBB33A221KP2A	1000	4.5	4.0	5.0	0.6	12.7	P2	1500
B	330	±10%		DEBB33A331KP2A	1000	4.5	4.0	5.0	0.6	12.7	P2	1500
B	470	±10%		DEBB33A471KP2A	1000	5.0	4.0	5.0	0.6	12.7	P2	1500
B	680	±10%		DEBB33A681KN2A	1000	6.0	4.0	5.0	0.6	12.7	N2	1500
B	1000	±10%		DEBB33A102KN2A	1000	6.0	4.0	5.0	0.6	12.7	N2	1500
B	1500	±10%		DEBB33A152KN2A	1000	8.0	4.0	5.0	0.6	12.7	N2	1500
B	2200	±10%		DEBB33A222KN2A	1000	9.0	4.0	5.0	0.6	12.7	N2	1500
B	3300	±10%		DEBB33A332KN2A	1000	10.0	4.0	5.0	0.6	12.7	N2	1500
B	4700	±10%		DEBB33A472KN3A	1000	12.0	4.0	7.5	0.6	15.0	N3	1000
B	6800	±10%		DEBB33A682KN7A	1000	15.0	4.0	7.5	0.6	30.0	N7	500
E	1000	+80/-20%		DEBE33A102ZP2A	1000	5.0	4.0	5.0	0.6	12.7	P2	1500
E	2200	+80/-20%		DEBE33A222ZN2A	1000	7.0	4.0	5.0	0.6	12.7	N2	1500
E	4700	+80/-20%		DEBE33A472ZN2A	1000	9.0	4.0	5.0	0.6	12.7	N2	1500
E	10000	+80/-20%		DEBE33A103ZN3A	1000	13.0	4.0	7.5	0.6	15.0	N3	1000
F	2200	+80/-20%		DEBF33A222ZN2A	1000	6.0	4.0	5.0	0.6	12.7	N2	1500
F	4700	+80/-20%		DEBF33A472ZN2A	1000	7.0	4.0	5.0	0.6	12.7	N2	1500
F	10000	+80/-20%		DEBF33A103ZN2A	1000	10.0	4.0	5.0	0.6	12.7	N2	1500

Reference only

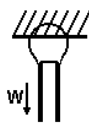
5. Specification and test methods													
No.	Item	Specification	Test method										
1	Appearance and dimensions	No marked defect on appearance form and dimensions. Please refer to [Part number list].	The capacitor should be inspected by naked eyes for visible evidence of defect. Dimensions should be measured with slide calipers.										
2	Marking	To be easily legible.	The capacitor should be inspected by naked eyes.										
3	Dielectric strength	Between lead wires	No failure.	The capacitor should not be damaged when DC voltage of 200% of the rated voltage are applied between the lead wires for 1 to 5 s. (Charge/Discharge current ≤ 50mA.) The capacitor is placed in the container with metal balls of diameter 1mm so that each lead wire, shortcircuited, is kept about 2mm off the balls as shown in the figure, and DC voltage of 1.3kV is applied for 1 to 5 s between capacitor lead wires and small metals. (Charge/Discharge current ≤ 50mA.)									
		Body insulation	No failure.										
4	Insulation Resistance (I.R.)	Between lead wires	10 000MΩ min.	The insulation resistance should be measured with DC500±50V within 60±5 s of charging.									
5	Capacitance		Within specified tolerance.	The capacitance should be measured at 20°C with 1±0.2kHz and AC5V(r.m.s.) max..									
6	Dissipation Factor (D.F.)		Char. B, E : 2.5% max. Char. F : 5.0% max.	The dissipation factor should be measured at 20°C with 1±0.2kHz and AC5V(r.m.s.) max..									
7	Temperature characteristic		Char. B : Within ±10% Char. E : Within +20/-55% Char. F : Within +30/-80%	The capacitance measurement should be made at each step specified in Table. Pre-treatment : Capacitor should be stored at 85±2°C for 1 h, then placed at *room condition for 24±2 h before initial measurements.									
			<table border="1" style="margin-left: auto; margin-right: auto; border-collapse: collapse;"> <thead> <tr> <th style="width: 10%;">Step</th> <th style="width: 10%;">1</th> <th style="width: 10%;">2</th> <th style="width: 10%;">3</th> <th style="width: 10%;">4</th> <th style="width: 10%;">5</th> </tr> </thead> <tbody> <tr> <td>Temp.(°C)</td> <td>20±2</td> <td>-25±3</td> <td>20±2</td> <td>85±2</td> <td>20±2</td> </tr> </tbody> </table>		Step	1	2	3	4	5	Temp.(°C)	20±2	-25±3
Step	1	2	3	4	5								
Temp.(°C)	20±2	-25±3	20±2	85±2	20±2								
8	Strength of lead	Pull	Lead wire should not cut off. Capacitor should not be broken.	As shown in the figure at right, fix the body of the capacitor and apply a tensile weight gradually to each lead wire in the radial direction of the capacitor up to 10N (5N for lead diameter 0.5mm), and keep it for 10±1 s. 									
		Bending			Each lead wire should be subjected to 5N (2.5N for lead diameter 0.5mm) of weight and bent 90° at the point of egress, in one direction, then returned to its original position, and bent 90° in the opposite direction at the rate of one bend in 2 to 3 s.								
9	Vibration resistance	Appearance	No marked defect.	The capacitor should be firmly soldered to the supporting lead wire and vibrated at a frequency range of 10 to 55Hz, 1.5mm in total amplitude, with about a 1min rate of vibration change from 10Hz to 55Hz and back to 10Hz. Apply for a total of 6 h; 2 h each in 3 mutually perpendicular directions.									
		Capacitance	Within specified tolerance.										
		D.F.	Char. B, E : 2.5% max. Char. F : 5.0% max.										
10	Solderability of leads		Lead wire should be soldered with uniformly coated on the axial direction over 3/4 of the circumferential direction.	The lead wire of a capacitor should be dipped into a ethanol solution of 25wt% rosin and then into molten solder for 2±0.5 s. In both cases the depth of dipping is up to about 1.5 to 2mm from the root of lead wires. Temp. of solder : 245±5°C Lead Free Solder (Sn-3Ag-0.5Cu) 235±5°C H63 Eutectic Solder									
* "room condition" Temperature: 15 to 35°C, Relative humidity: 45 to 75%, Atmospheric pressure: 86 to 106kPa													

Reference only

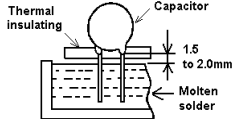
No.	Item	Specification	Test method
11	Soldering effect (Non-preheat)	Appearance	No marked defect.
		Capacitance change	Char. B : Within $\pm 5\%$ Char. E : Within $\pm 15\%$ Char. F : Within $\pm 20\%$
		Dielectric strength (Between lead wires)	Per item 3.
The lead wire should be immersed into the melted solder of $350\pm 10^{\circ}\text{C}$ (Body of $\phi 5$ and under: $270\pm 5^{\circ}\text{C}$) up to about 1.5 to 2.0mm from the main body for 3.5 ± 0.5 s. (Body of $\phi 5$ and under: 5 ± 0.5 s.) Pre-treatment : Capacitor should be stored at $85\pm 2^{\circ}\text{C}$ for 1 h, then placed at * room condition for 24 ± 2 h before initial measurements. Post-treatment : Capacitor should be stored for 4 to 24 h at * room condition.			
12	Soldering effect (On-preheat)	Appearance	No marked defect.
		Capacitance change	Char. B : Within $\pm 5\%$ Char. E : Within $\pm 15\%$ Char. F : Within $\pm 20\%$
		Dielectric strength (Between lead wires)	Per item 3.
First the capacitor should be stored at $120+0/-5^{\circ}\text{C}$ for $60+0/-5$ s. Then, as in figure, the lead wires should be immersed solder of $260+0/-5^{\circ}\text{C}$ up to 1.5 to 2.0mm from the root of terminal for $7.5+0/-1$ s.  Pre-treatment : Capacitor should be stored at $85\pm 2^{\circ}\text{C}$ for 1 h, then placed at * room condition for 24 ± 2 h before initial measurements. Post-treatment : Capacitor should be stored for 4 to 24 h at * room condition.			
13	Humidity (Under steady state)	Appearance	No marked defect.
		Capacitance change	Char. B : Within $\pm 10\%$ Char. E : Within $\pm 20\%$ Char. F : Within $\pm 30\%$
		D.F.	Char. B,E : 5.0% max. Char. F : 7.5% max.
		I.R.	1 000M Ω min.
Set the capacitor for $500 +24/-0$ h at $40\pm 2^{\circ}\text{C}$ in 90 to 95% relative humidity. Pre-treatment : Capacitor should be stored at $85\pm 2^{\circ}\text{C}$ for 1 h, then placed at * room condition for 24 ± 2 h before initial measurements. Post-treatment : Capacitor should be stored for 1 to 2 h at * room condition.			
14	Humidity loading	Appearance	No marked defect.
		Capacitance change	Char. B : Within $\pm 10\%$ Char. E : Within $\pm 20\%$ Char. F : Within $\pm 30\%$
		D.F.	Char. B,E : 5.0% max. Char. F : 7.5% max.
		I.R.	500M Ω min.
Apply the rated voltage for $500 +24/-0$ h at $40\pm 2^{\circ}\text{C}$ in 90 to 95% relative humidity. (Charge/Discharge current $\leq 50\text{mA}$.) Pre-treatment : Capacitor should be stored at $85\pm 2^{\circ}\text{C}$ for 1 h, then placed at * room condition for 24 ± 2 h before initial measurements. Post-treatment : Capacitor should be stored at $85\pm 2^{\circ}\text{C}$ for 1 h, then placed at * room condition for 24 ± 2 h.			
15	Life	Appearance	No marked defect.
		Capacitance change	Char. B : Within $\pm 10\%$ Char. E : Within $\pm 20\%$ Char. F : Within $\pm 30\%$
		D.F.	Char. B,E : 4.0% max. Char. F : 7.5% max.
		I.R.	2 000M Ω min.
Apply a DC voltage of 150% of the rated voltage for $1000 +48/-0$ h at $85\pm 2^{\circ}\text{C}$, and relative humidity of 50% max.. (Charge/Discharge current $\leq 50\text{mA}$.) Pre-treatment : Capacitor should be stored at $85\pm 2^{\circ}\text{C}$ for 1 h, then placed at * room condition for 24 ± 2 h before initial measurements. Post-treatment : Capacitor should be stored at $85\pm 2^{\circ}\text{C}$ for 1 h, then placed at * room condition for 24 ± 2 h.			
* "room condition" Temperature: 15 to 35°C , Relative humidity: 45 to 75%, Atmospheric pressure: 86 to 106kPa			

Reference only

No.	Item	Specification	Test method																											
16	Temperature and Immersion cycle	Appearance	The capacitor should be subjected to 5 temperature cycles, then consecutively to 2 immersion cycles. <Temperature cycle> <table border="1" data-bbox="997 280 1372 414"> <thead> <tr> <th>Step</th> <th>Temperature(°C)</th> <th>Time</th> </tr> </thead> <tbody> <tr> <td>1</td> <td>-25±3</td> <td>30 min</td> </tr> <tr> <td>2</td> <td>Room Temp.</td> <td>3 min</td> </tr> <tr> <td>3</td> <td>+85±3</td> <td>30 min</td> </tr> <tr> <td>4</td> <td>Room Temp.</td> <td>3 min</td> </tr> </tbody> </table> Cycle time : 5 cycle <Immersion cycle> <table border="1" data-bbox="986 481 1476 627"> <thead> <tr> <th>Step</th> <th>Temperature(°C)</th> <th>Time</th> <th>Immersion water</th> </tr> </thead> <tbody> <tr> <td>1</td> <td>+65+5/-0</td> <td>15 min</td> <td>Clean water</td> </tr> <tr> <td>2</td> <td>0±3</td> <td>15 min</td> <td>Salt water</td> </tr> </tbody> </table> Cycle time : 2 cycle Pre-treatment : Capacitor should be stored at 85±2°C for 1 h, then placed at * room condition for 24±2 h before initial measurements. Post-treatment : Capacitor should be stored for 4 to 24 h at * room condition.	Step	Temperature(°C)	Time	1	-25±3	30 min	2	Room Temp.	3 min	3	+85±3	30 min	4	Room Temp.	3 min	Step	Temperature(°C)	Time	Immersion water	1	+65+5/-0	15 min	Clean water	2	0±3	15 min	Salt water
		Step		Temperature(°C)	Time																									
		1		-25±3	30 min																									
		2		Room Temp.	3 min																									
3	+85±3	30 min																												
4	Room Temp.	3 min																												
Step	Temperature(°C)	Time	Immersion water																											
1	+65+5/-0	15 min	Clean water																											
2	0±3	15 min	Salt water																											
Capacitance change	Char. B : Within ±10% Char. E : Within ±20% Char. F : Within ±30%																													
D.F.	Char. B,E : 4.0% max. Char. F : 7.5% max.																													
I.R.	2000MΩ min.																													
	Dielectric strength (Between lead wires)	Per item 3.																												

* "room condition" Temperature: 15 to 35°C, Relative humidity: 45 to 75%, Atmospheric pressure: 86 to 106kPa

Reference only

6.Packing specification

- Bulk type (Packing style code : B)

The number of packing = $\frac{\text{Packing quantity}}{\text{Packing quantity}} \times n$

The size of packing case and packing way

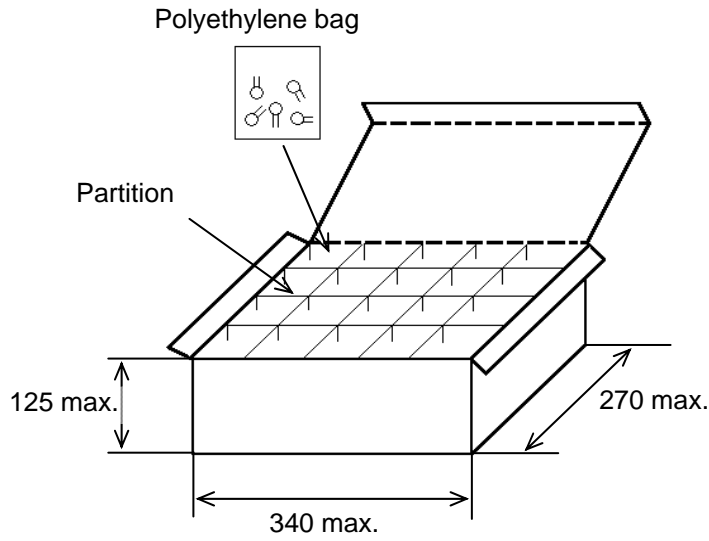

- *1 : Please refer to [Part number list].
- *2 : Standard n = 20 (bag)

Note)
The outer package and the number of outer packing be changed by the order getting amount.

Unit : mm

- Ammo pack taping type (Packing style code : A)

- The tape with capacitors is packed zigzag into a case.
- When body of the capacitor is piled on other body under it.
- There should be 3 pitches and over without capacitors in leader and trailer.

The size of packing case and packing way

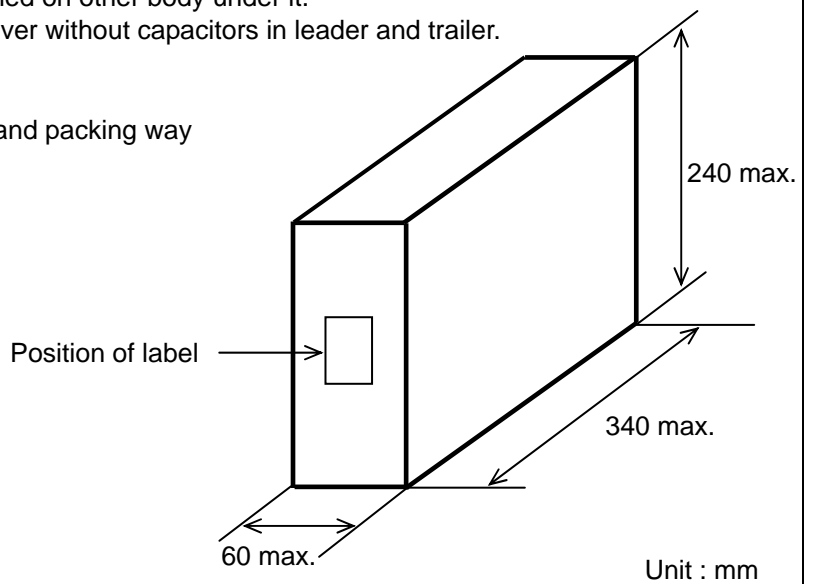

Unit : mm

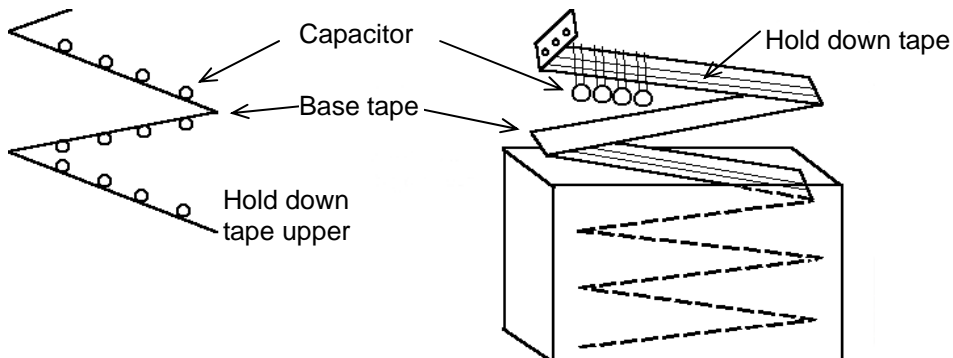

Reference only

7. Taping specification

7-1. Dimension of capacitors on tape

Vertical crimp taping type < Lead code : N2 >

Pitch of component 12.7mm / Lead spacing 5.0mm

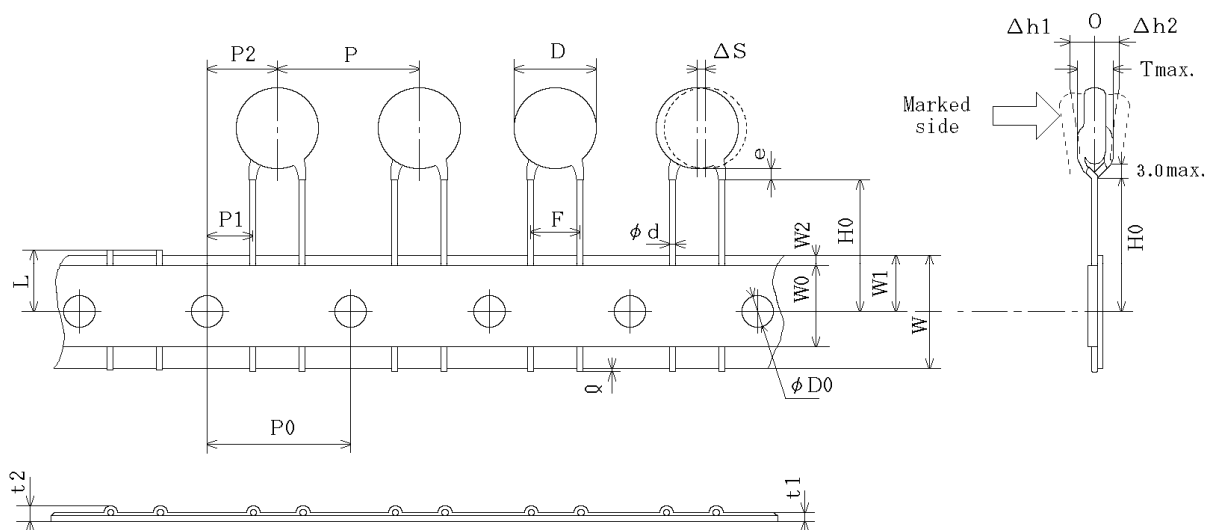

Unit : mm

Item	Code	Dimensions	Remarks
Pitch of component	P	12.7±1.0	
Pitch of sprocket hole	P0	12.7±0.3	
Lead spacing	F	5.0 ^{0.8} ±0.2	
Length from hole center to component center	P2	6.35±1.3	Deviation of progress direction
Length from hole center to lead	P1	3.85±0.7	
Body diameter	D	Please refer to [Part number list].	
Deviation along tape, left or right	ΔS	0±1.0	They include deviation by lead bend .
Carrier tape width	W	18.0±0.5	
Position of sprocket hole	W1	9.0±0.5	Deviation of tape width direction
Lead distance between reference and bottom planes	H0	18.0± ₀ ^{2.0}	
Protrusion length	Q	+0.5~-1.0	
Diameter of sprocket hole	φD0	4.0±0.1	
Lead diameter	φd	0.60±0.05	
Total tape thickness	t1	0.6±0.3	They include hold down tape thickness.
Total thickness, tape and lead wire	t2	1.5 max.	
Deviation across tape, front	Δh1	1.0 max.	
Deviation across tape, rear	Δh2		
Portion to cut in case of defect	L	11.0± _{1.0} ⁰	
Hold down tape width	W0	11.5 min.	
Hold down tape position	W2	1.5±1.5	
Coating extension on lead	e	Up to the end of crimp	
Body thickness	T	Please refer to [Part number list].	

Reference only

Vertical crimp taping type < Lead code : N3 >
Pitch of component 15.0mm / Lead spacing 7.5mm

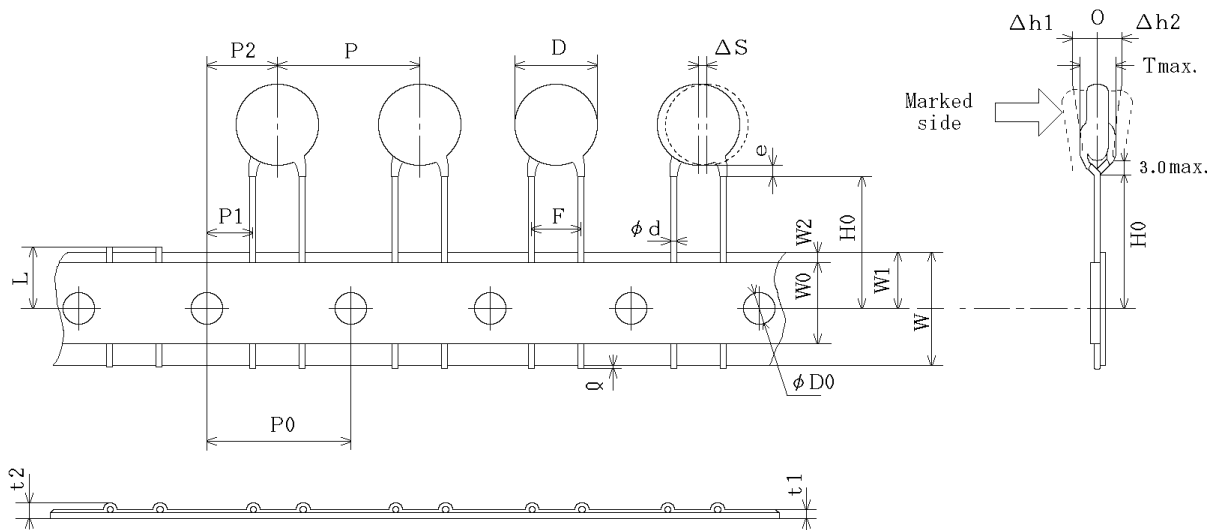

Unit : mm

Item	Code	Dimensions	Remarks
Pitch of component	P	15.0±2.0	
Pitch of sprocket hole	P0	15.0±0.3	
Lead spacing	F	7.5±1.0	
Length from hole center to component center	P2	7.5±1.5	Deviation of progress direction
Length from hole center to lead	P1	3.75±1.0	
Body diameter	D	Please refer to [Part number list].	
Deviation along tape, left or right	ΔS	0±2.0	They include deviation by lead bend .
Carrier tape width	W	18.0±0.5	
Position of sprocket hole	W1	9.0±0.5	Deviation of tape width direction
Lead distance between reference and bottom planes	H0	18.0 ^{+2.0} ₀	
Protrusion length	Q	+0.5~-1.0	
Diameter of sprocket hole	φD0	4.0±0.1	
Lead diameter	φd	0.60±0.05	
Total tape thickness	t1	0.6±0.3	They include hold down tape thickness.
Total thickness, tape and lead wire	t2	1.5 max.	
Deviation across tape, front	Δh1	2.0 max.	
Deviation across tape, rear	Δh2		
Portion to cut in case of defect	L	11.0 ⁰ ±1.0	
Hold down tape width	W0	11.5 min.	
Hold down tape position	W2	1.5±1.5	
Coating extension on lead	e	Up to the end of crimp	
Body thickness	T	Please refer to [Part number list].	

Reference only

Vertical crimp taping type < Lead code : N7 >
Pitch of component 30.0mm /Lead spacing 7.5mm

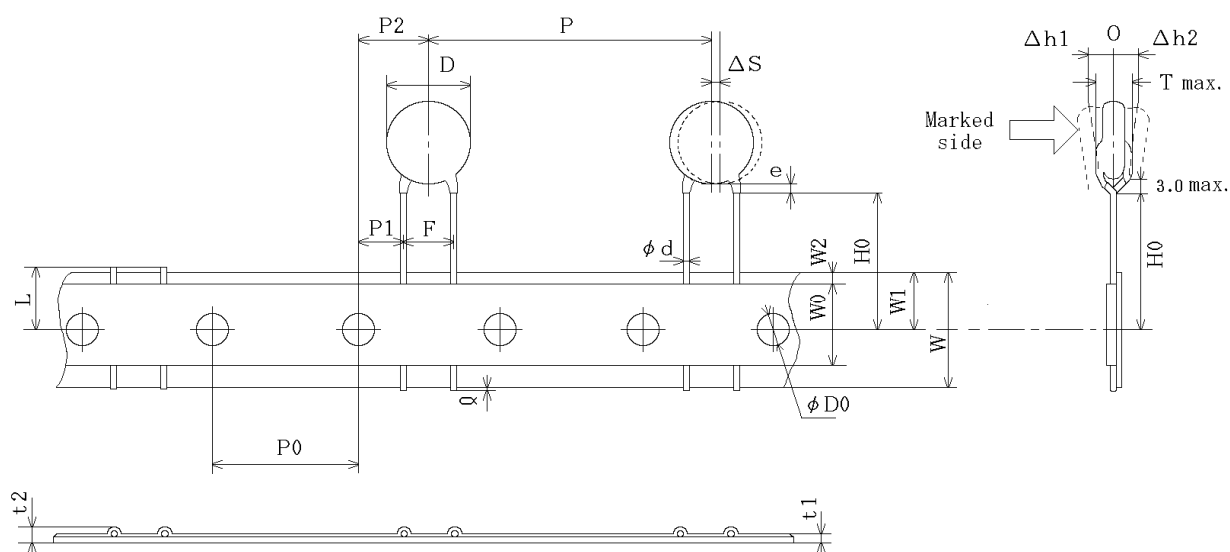

Unit : mm

Item	Code	Dimensions	Remarks
Pitch of component	P	30.0±2.0	
Pitch of sprocket hole	P0	15.0±0.3	
Lead spacing	F	7.5±1.0	
Length from hole center to component center	P2	7.5±1.5	Deviation of progress direction
Length from hole center to lead	P1	3.75±1.0	
Body diameter	D	Please refer to [Part number list].	
Deviation along tape, left or right	ΔS	0±2.0	They include deviation by lead bend.
Carrier tape width	W	18.0±0.5	
Position of sprocket hole	W1	9.0±0.5	Deviation of tape width direction
Lead distance between reference and bottom planes	H0	18.0 ^{+2.0} ₀	
Protrusion length	Q	+0.5~-1.0	
Diameter of sprocket hole	φD0	4.0±0.1	
Lead diameter	φd	0.60±0.05	
Total tape thickness	t1	0.6±0.3	They include hold down tape thickness.
Total thickness, tape and lead wire	t2	1.5 max.	
Deviation across tape, front	Δh1	2.0 max.	
Deviation across tape, rear	Δh2		
Portion to cut in case of defect	L	11.0 ⁰ ±1.0	
Hold down tape width	W0	11.5 min.	
Hold down tape position	W2	1.5±1.5	
Coating extension on lead	e	Up to the end of crimp	
Body thickness	T	Please refer to [Part number list].	

Reference only

Straight taping type < Lead code: P2 >
Pitch of component 12.7mm / Lead spacing 5.0mm

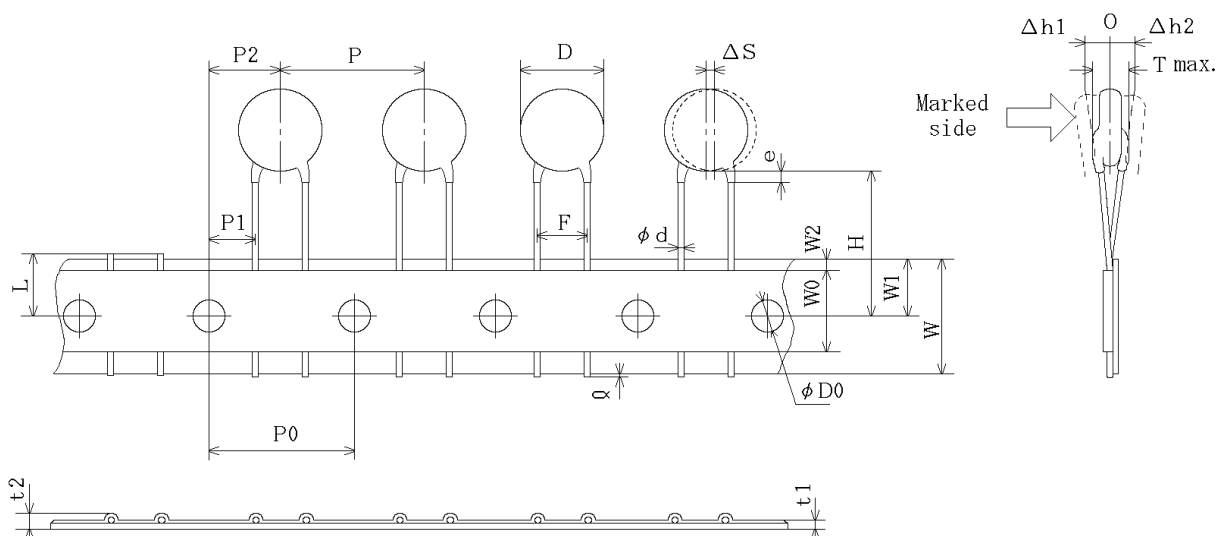

Unit : mm

Item	Code	Dimensions	Remarks
Pitch of component	P	12.7±1.0	
Pitch of sprocket hole	P0	12.7±0.3	
Lead spacing	F	5.0 ^{0.8} ±0.2	
Length from hole center to component center	P2	6.35±1.3	Deviation of progress direction
Length from hole center to lead	P1	3.85±0.7	
Body diameter	D	Please refer to [Part number list].	
Deviation along tape, left or right	ΔS	0±1.0	They include deviation by lead bend .
Carrier tape width	W	18.0±0.5	
Position of sprocket hole	W1	9.0±0.5	Deviation of tape width direction
Lead distance between reference and bottom planes	H	20.0 ^{1.5} ±1.0	
Protrusion length	Q	+0.5~-1.0	
Diameter of sprocket hole	φD0	4.0±0.1	
Lead diameter	φd	0.60±0.05	
Total tape thickness	t1	0.6±0.3	They include hold down tape thickness.
Total thickness, tape and lead wire	t2	1.5 max.	
Deviation across tape, front	Δh1	1.0 max.	
Deviation across tape, rear	Δh2		
Portion to cut in case of defect	L	11.0 ⁰ ±1.0	
Hold down tape width	W0	11.5 min.	
Hold down tape position	W2	1.5±1.5	
Coating extension on lead	e	3.0 max.	
Body thickness	T	Please refer to [Part number list].	

Reference only

7-2. Splicing way of tape

- 1) Adhesive force of tape is over 3N at test condition as below.

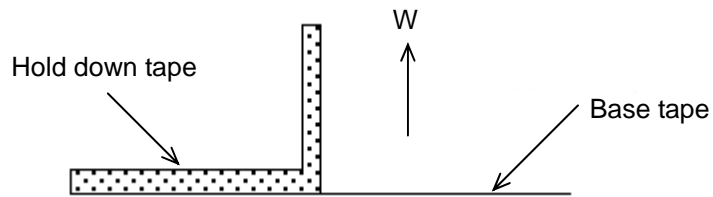

2) Splicing of tape

- a) When base tape is spliced

- Base tape should be spliced by cellophane tape.
(Total tape thickness should be less than 1.05mm.)

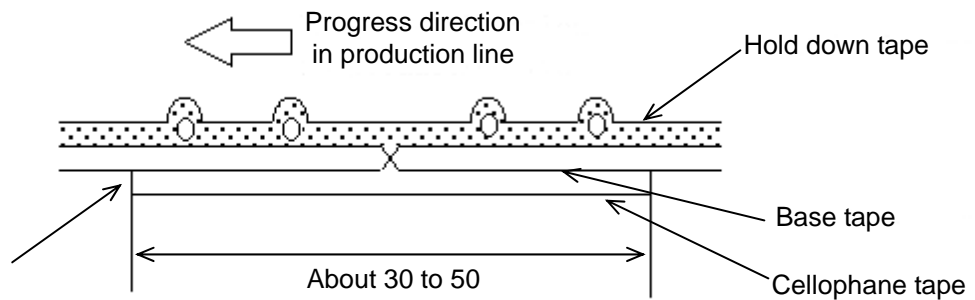

No lifting for the direction of progressing

Unit : mm

- b) When hold down tape is spliced

- Hold down tape should be spliced with overlapping.
(Total tape thickness should be less than 1.05mm.)

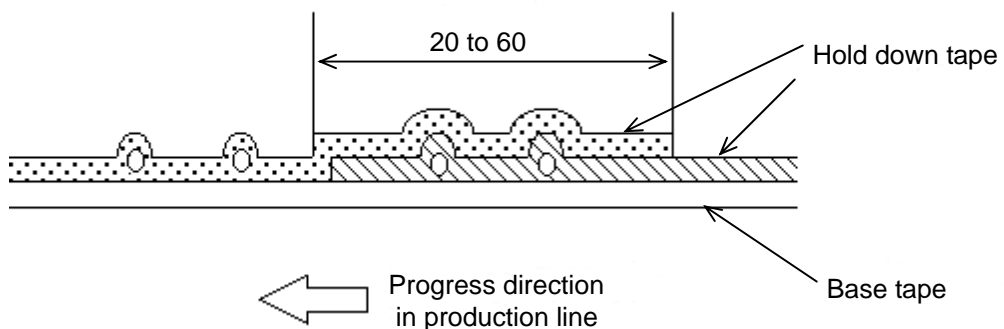

Unit : mm

- c) When both tape are spliced

- Base tape and hold down tape should be spliced with splicing tape.

3) Missing components

- There should be no consecutive missing of more than three components.
- The number of missing components should be not more than 0.5% of total components that should be present in a Ammo pack.

EU RoHS

This products of the following crresponds to EU RoHS.

RoHS

maximum concentration values tolerated by weight in homogeneous materials

- 1000 ppm maximum Lead
- 1000 ppm maximum Mercury
- 100 ppm maximum Cadmium
- 1000 ppm maximum Hexavalent chromium
- 1000 ppm maximum Polybrominated biphenyls (PBB)
- 1000 ppm maximum Polybrominated diphenyl ethers (PBDE)