

CMOS Voltage Converters

CMOS Voltage Converters

The Intersil LMC7660 are monolithic CMOS power supply circuits which offer unique performance advantages over previously available devices. The LMC7660 performs supply voltage conversions from positive to negative for an input range of +1.5V to +10.0V resulting in complementary output voltages of -1.5V to -10.0V.

Only 2 noncritical external capacitors are needed for the charge pump and charge reservoir functions.

The LMC7660 can also be connected to function as voltage doublers and will generate output voltages up to +18.6V with a +10V input.

Contained on the chip are a series DC supply regulator, RC oscillator, voltage level translator, and four output power MOS switches. A unique logic element senses the most negative voltage in the device and ensures that the output N-Channel switch source-substrate junctions are not forward biased. This assures latchup free operation. The oscillator, when unloaded, oscillates at a nominal frequency of 10kHz for an input supply voltage of 5.0V. This frequency can be lowered by the addition of an external capacitor to the "OSC" terminal, or the oscillator may be overdriven by an external clock.

The "LV" terminal may be tied to GROUND to bypass the internal series regulator and improve low voltage (LV) operation. At medium to high voltages (+3.5V to +10.0V), the LV pin is left floating to prevent device latchup.

Pinouts

DIP8/SOP8

TOP VIEW

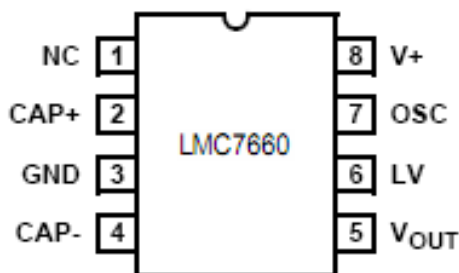

Pin Description

Name	Pin#	Function
NC	1	
CAP+	2	"+" Capacitor Plate
GND	3	Ground
CAP-	4	"-" Capacitor Plate
V _{OUT}	5	Output Voltage
LV	6	Low Supply Voltage
OSC	7	Oscillator
V+	8	Supply Voltage

Features

- Simple Conversion of +5V Logic Supply to ±5V Supplies
- Simple Voltage Multiplication ($V_{OUT} = (-) nV_{IN}$)
- Typical Open Circuit Voltage Conversion Efficiency 99.9%
- Typical Power Efficiency 98%
- Wide Operating Voltage Range
LMC7660 1.5V to 10.0V
- Easy to Use - Requires Only 2 External Non-Critical Passive Components

Applications

- On Board Negative Supply for Dynamic RAMs
- Localized μ Processor (8080 Type) Negative Supplies
- Inexpensive Negative Supplies
- Data Acquisition Systems

Absolute Maximum Ratings

Supply Voltage

LMC7660 +10.5V

 LV and OSC Input Voltage -0.3V to (V+ +0.3V) for V+ < 5.5V
 (V+ -5.5V) to (V+ +0.3V) for V+ > 5.5V

Current into LV 20μA for V+ > 3.5V

Temperature Range 0°C to 70°C

 Thermal Resistance, θ_{JA} (°C/W)150

Maximum Storage Temperature Range -65°C to 150°C

Electrical Characteristics (V+ = 5V, T_A = 25°C, C_{OSC} = 0, unless otherwise specified)

PARAMETER	SYMBOL	TEST CONDITIONS	MIN	TYP	MAX	UNITS
Supply Current	I+	R _L = ∞	-	170	500	μA
Supply Voltage Range - Lo	VL+	MIN ≤ T _A ≤ MAX, R _L = 10kΩ, LV to GND	1.5	-	3.5	V
Supply Voltage Range - Hi	VL+	MIN ≤ T _A ≤ MAX, R _L = 10kΩ, LV to Open	3.0	-	10.0	V
Output Source Resistans	R _{OUT}	I _{OUT} = 20mA, T _A = 25°C	-	55	100	Ω
		I _{OUT} = 20mA, 0°C ≤ T _A ≤ 70°C	-	-	120	
		V+ = 2V, I _{OUT} = 3mA, LV to GND, 0°C ≤ T _A ≤ 70°C	-	-	300	
Oscillator Frequency	f _{OSC}		8	-	18	kHz
Power Efficiency	P _{EF}	R _L = 5kΩ	95	98	-	%
Voltage Conversion Efficiency	V _{OUT EF}	R _L = ∞	97	99.9	-	%
Oscillator Impedance	Z _{OSC}	V+ = 2V	-	1.0	-	MΩ
		V+ = 5V	-	100	-	kΩ

TYPICAL APPLICATION CIRCUITS

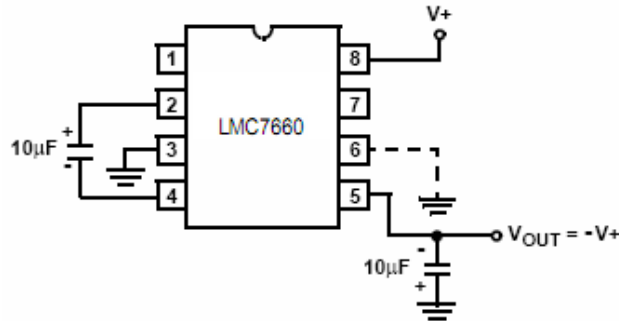

FIGURE 1. SIMPLE NEGATIVE CONVERTER

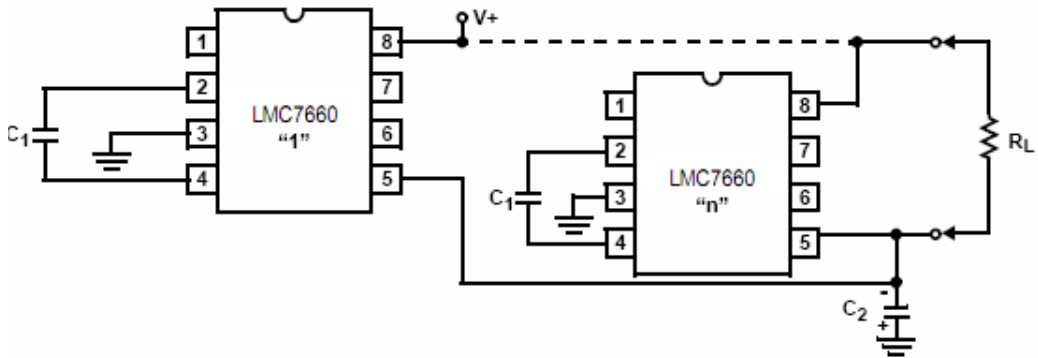

FIGURE 2. PARALLELING DEVICES

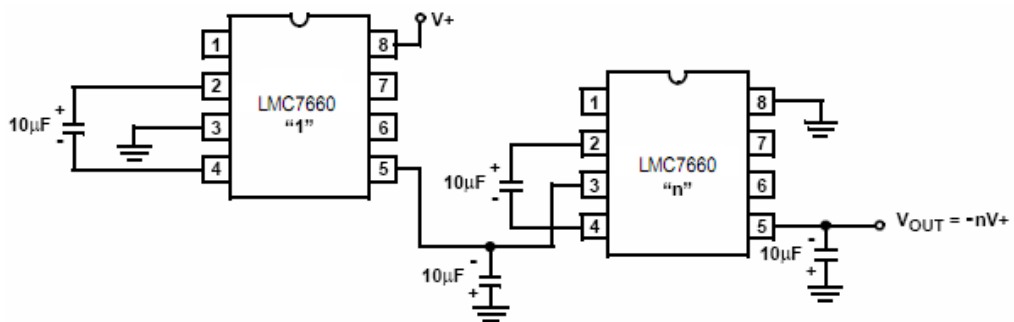

FIGURE 3. CASCADING DEVICES FOR INCREASED OUTPUT VOLTAGE

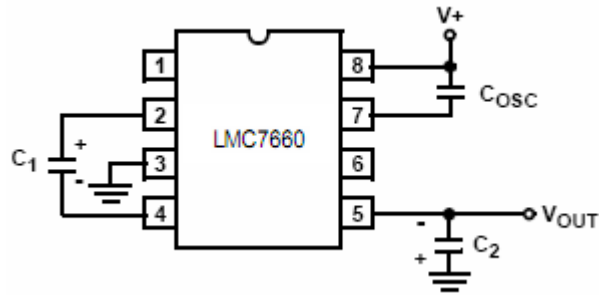

FIGURE 4. LOWERING OSCILLATOR FREQUENCY

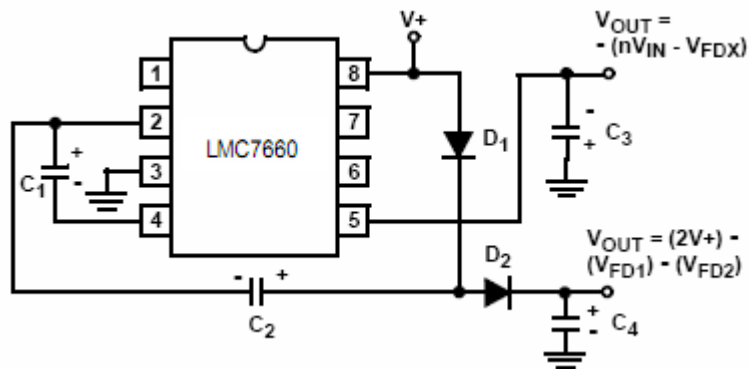

FIGURE 5. COMBINED NEGATIVE VOLTAGE CONVERTER AND POSITIVE DOUBLER

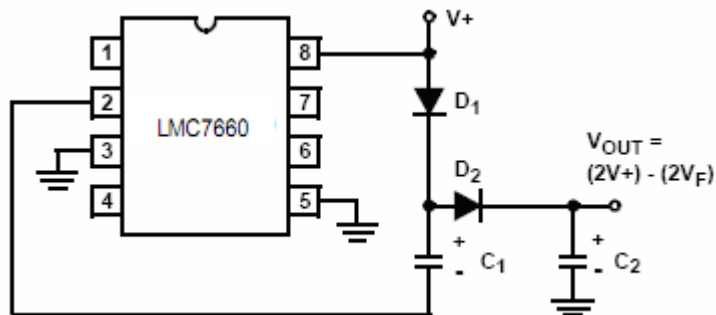

FIGURE 6. POSITIVE VOLT DOUBLER

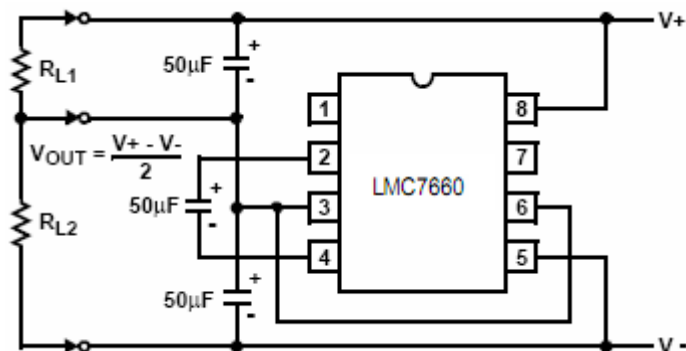

FIGURE 7. SPLITTING A SUPPLY IN HALF

Important statement:

Huaguan Semiconductor Co,Ltd. reserves the right to change the products and services provided without notice. Customers should obtain the latest relevant information before ordering, and verify the timeliness and accuracy of this information.

Customers are responsible for complying with safety standards and taking safety measures when using our products for system design and machine manufacturing to avoid potential risks that may result in personal injury or property damage.

Our products are not licensed for applications in life support, military, aerospace, etc., so we do not bear the consequences of the application of these products in these fields.

Our documentation is only permitted to be copied without any tampering with the content, so we do not accept any responsibility or liability for the altered documents.