

# XD124/XD224/XD324/XD2902N DIP14 XL124/XL224/XL324/XL2902 SOP14

## FEATURES

- **2-kV ESD Protection for:**
  - XD224, XL224
  - XD324, XL324
  - XD2902, XL2902
- **Wide Supply Ranges**
  - **Single Supply:** 3 V to 32 V (26 V for XD2902)
  - **Dual Supplies:** ±1.5 V to ±16 V (±13 V for XL2902)
- **Low Supply-Current Drain Independent of Supply Voltage: 0.8 mA Typ**
- **Common-Mode Input Voltage Range Includes Ground, Allowing Direct Sensing Near Ground**
- **Low Input Bias and Offset Parameters**
  - **Input Offset Voltage:** 3 mV Typ  
     A Versions: 2 mV Typ
  - **Input Offset Current:** 2 nA Typ
  - **Input Bias Curren:** 20 nA Typ  
     A Versions: 15 nA Typ
- **Differential Input Voltage Range Equal to Maximum-Rated Supply Voltage: 32 V (26 V for XD2902)**
- **Open-Loop Differential Voltage Amplification: 100 V/mV Typ**
- **Internal Frequency Compensation**
- **On Products Compliant to MIL-PRF-38535, All Parameters Are Tested Unless Otherwise Noted. On All Other Products, Production Processing Does Not Necessarily Include Testing of All Parameters.**

## DESCRIPTION

These devices consist of four independent high-gain frequency-compensated operational amplifiers that are designed specifically to operate from a single supply over a wide range of voltages. Operation from split supplies also is possible if the difference between the two supplies is 3 V to 32 V (3 V to 26 V for the XD2902 device), and  $V_{CC}$  is at least 1.5 V more positive than the input common-mode voltage. The low supply-current drain is independent of the magnitude of the supply voltage.

Applications include transducer amplifiers, dc amplification blocks, and all the conventional operational-amplifier circuits that now can be more easily implemented in single-supply-voltage systems. For example, the XD124 device can be operated directly from the standard 5-V supply that is used in digital systems and provides the required interface electronics, without requiring additional ±15-V supplies.

## XD124/XD224/XD324/XD2902N XL124/XL224/XL324/XL2902

(TOP VIEW)

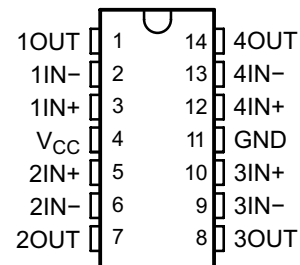

# XD124/XD224/XD324/XD2902N DIP14 XL124/XL224/XL324/XL2902 SOP14

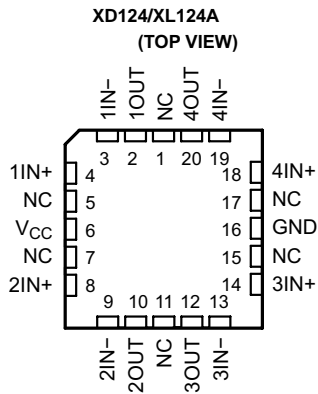

NC - No internal connection

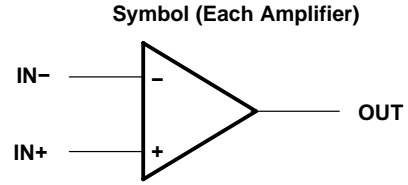

## Schematic (Each Amplifier)

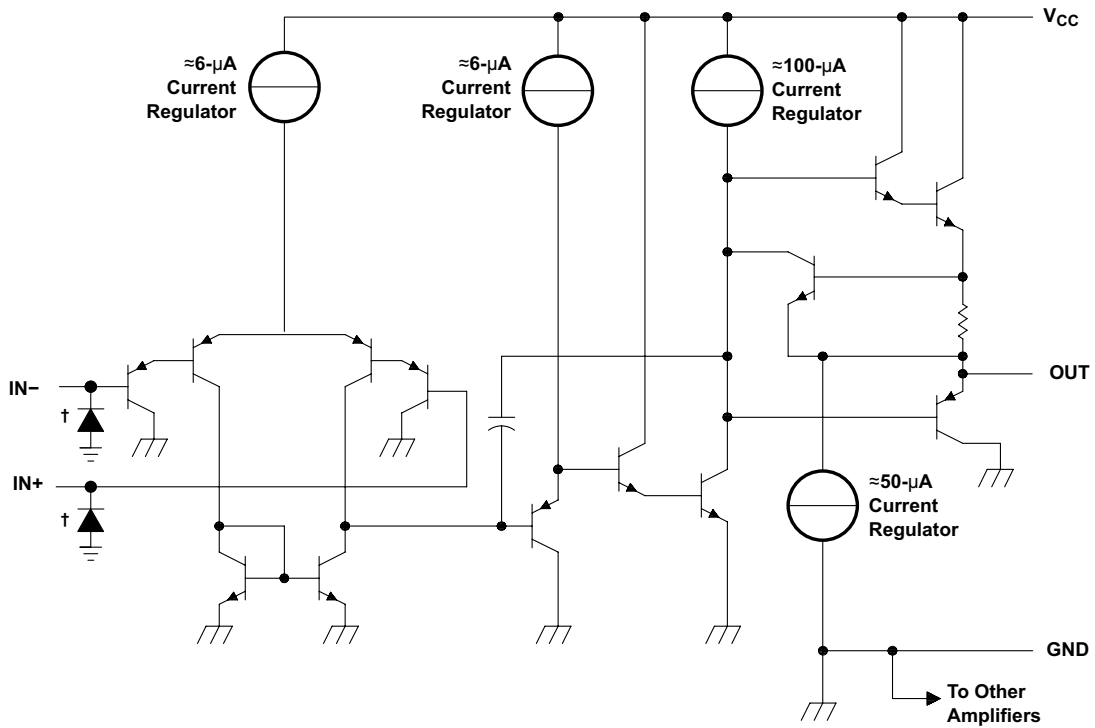

COMPONENT COUNT (total device)	
Epi-FET	1
Transistors	95
Diodes	4
Resistors	11
Capacitors	4

† ESD protection cells - available on XD324 and XL324 only

# XD124/XD224/XD324/XD2902N DIP14 XL124/XL224/XL324/XL2902 SOP14

## Absolute Maximum Ratings

over operating free-air temperature range (unless otherwise noted)<sup>(1)</sup>

		XD2902	ALL OTHER DEVICES	UNIT
Supply voltage, $V_{CC}$ <sup>(2)</sup>		±13 or 26	±16 or 32	V
Differential input voltage, $V_{ID}$ <sup>(3)</sup>		±26	±32	V
Input voltage, $V_I$ (either input)		-0.3 to 26	-0.3 to 32	V
Duration of output short circuit (one amplifier) to ground at (or below) $T_A = 25^\circ\text{C}$ , $V_{CC} \leq 15\text{ V}$ <sup>(4)</sup>		Unlimited	Unlimited	
Package thermal impedance, $\theta_{JA}$ <sup>(4)(5)</sup>	D package	86	86	°C/W
	DB package	96	96	
	N package	80	80	
	NS package	76	76	
	PW package	113	113	
Package thermal impedance, $\theta_{JC}$ <sup>(6)(7)</sup>	FK package		5.61	°C/W
	J package		15.05	
	W package		14.65	
Operating virtual junction temperature, $T_J$		150	150	°C
Case temperature for 60 seconds		FK package	260	°C
Lead temperature 1,6 mm (1/16 inch) from case for 60 seconds		J or W package	300	°C
Storage temperature range, $T_{stg}$		-65 to 150	-65 to 150	°C

- (1) Stresses beyond those listed under *Absolute Maximum Ratings* may cause permanent damage to the device. These are stress ratings only, and functional operation of the device at these or any other conditions beyond those indicated under *Recommended Operating Conditions* is not implied. Exposure to absolute-maximum-rated conditions for extended periods may affect device reliability.
- (2) All voltage values (except differential voltages and  $V_{CC}$  specified for the measurement of  $I_{OS}$ ) are with respect to the network GND.
- (3) Differential voltages are at IN+, with respect to IN-.
- (4) Short circuits from outputs to  $V_{CC}$  can cause excessive heating and eventual destruction.
- (5) Maximum power dissipation is a function of  $T_{J(max)}$ ,  $\theta_{JA}$ , and  $T_A$ . The maximum allowable power dissipation at any allowable ambient temperature is  $P_D = (T_{J(max)} - T_A)/\theta_{JA}$ . Operating at the absolute maximum  $T_J$  of 150°C can affect reliability.
- (6) Maximum power dissipation is a function of  $T_{J(max)}$ ,  $\theta_{JA}$ , and  $T_C$ . The maximum allowable power dissipation at any allowable case temperature is  $P_D = (T_{J(max)} - T_C)/\theta_{JC}$ . Operating at the absolute maximum  $T_J$  of 150°C can affect reliability.
- (7) The package thermal impedance is calculated in accordance with MIL-STD-883

## ESD Protection

TEST CONDITIONS		TYP	UNIT
Human-Body Model	XD224, XL224, XD324, XL324, XD2902, XL2902,	±2	kV

# XD124/XD224/XD324/XD2902N DIP14 XL124/XL224/XL324/XL2902 SOP14

## Electrical Characteristics

at specified free-air temperature,  $V_{CC} = 5\text{ V}$  (unless otherwise noted)

PARAMETER	TEST CONDITIONS <sup>(1)</sup>	$T_A$ <sup>(2)</sup>	XD124, XD224			XD324 XL324			UNIT		
			MIN	TYP <sup>(3)</sup>	MAX	MIN	TYP <sup>(3)</sup>	MAX			
$V_{IO}$ Input offset voltage	$V_{CC} = 5\text{ V to MAX}$ , $V_{IC} = V_{ICRmin}$ , $V_O = 1.4\text{ V}$	25°C		3	5		3	7	mV		
		Full range			7			9			
$I_{IO}$ Input offset current	$V_O = 1.4\text{ V}$	25°C		2	30		2	50	nA		
		Full range			100			150			
$I_{IB}$ Input bias current	$V_O = 1.4\text{ V}$	25°C		-20	-150		-20	-250	nA		
		Full range			-300			-500			
$V_{ICR}$ Common-mode input voltage range	$V_{CC} = 5\text{ V to MAX}$	25°C		0 to $V_{CC} - 1.5$			0 to $V_{CC} - 1.5$		V		
		Full range		0 to $V_{CC} - 2$			0 to $V_{CC} - 2$				
$V_{OH}$ High-level output voltage	$R_L = 2\text{ k}\Omega$	25°C		$V_{CC} - 1.5$			$V_{CC} - 1.5$		V		
		25°C		$V_{CC} - 1.5$			$V_{CC} - 1.5$				
	$V_{CC} = \text{MAX}$	$R_L = 2\text{ k}\Omega$	Full range		26		26				
		$R_L \geq 10\text{ k}\Omega$	Full range		27	28	27	28			
$V_{OL}$ Low-level output voltage	$R_L \leq 10\text{ k}\Omega$	Full range		5	20		5	20	mV		
$A_{VD}$ Large-signal differential voltage amplification	$V_{CC} = 15\text{ V}$ , $V_O = 1\text{ V to }11\text{ V}$ , $R_L \geq 2\text{ k}\Omega$	25°C		50	100		25	100	V/mV		
		Full range		25			15				
CMRR Common-mode rejection ratio	$V_{IC} = V_{ICRmin}$	25°C		70	80		65	80	dB		
$k_{SVR}$ Supply-voltage rejection ratio ( $\Delta V_{CC}/\Delta V_{IO}$ )		25°C		65	100		65	100	dB		
$V_{O1}/V_{O2}$ Crosstalk attenuation	$f = 1\text{ kHz to }20\text{ kHz}$	25°C		120			120			dB	
$I_O$ Output current	$V_{CC} = 15\text{ V}$ , $V_{ID} = 1\text{ V}$ , $V_O = 0$	Source	25°C		-20	-30	-60	-20	-30	-60	mA
			Full range		-10			-10			
	$V_{CC} = 15\text{ V}$ , $V_{ID} = -1\text{ V}$ , $V_O = 15\text{ V}$	Sink	25°C		10	20		10	20		
			Full range		5			5			
	$V_{ID} = -1\text{ V}$ , $V_O = 200\text{ mV}$	25°C		12	30		12	30	$\mu\text{A}$		
$I_{OS}$ Short-circuit output current	$V_{CC}$ at 5 V, $V_O = 0$ , GND at -5 V	25°C		$\pm 40$	$\pm 60$		$\pm 40$	$\pm 60$	mA		
$I_{CC}$ Supply current (four amplifiers)	$V_O = 2.5\text{ V}$ , No load	Full range		0.7	1.2		0.7	1.2	mA		
	$V_{CC} = \text{MAX}$ , $V_O = 0.5 V_{CC}$ , No load	Full range		1.4	3		1.4	3			

- (1) All characteristics are measured under open-loop conditions, with zero common-mode input voltage, unless otherwise specified. MAX  $V_{CC}$  for testing purposes is 26 V for XD2902 and 30 V for the others.
- (2) Full range is  $-55^\circ\text{C}$  to  $125^\circ\text{C}$  for LM124,  $-25^\circ\text{C}$  to  $85^\circ\text{C}$  for LM224, and  $0^\circ\text{C}$  to  $70^\circ\text{C}$  for XD324.
- (3) All typical values are at  $T_A = 25^\circ\text{C}$

# XD124/XD224/XD324/XD2902N DIP14 XL124/XL224/XL324/XL2902 SOP14

## Electrical Characteristics

at specified free-air temperature,  $V_{CC} = 5\text{ V}$  (unless otherwise noted)

PARAMETER	TEST CONDITIONS <sup>(1)</sup>		$T_A$ <sup>(2)</sup>	XD2902			XL2902			UNIT		
				MIN	TYP <sup>(3)</sup>	MAX	MIN	TYP <sup>(3)</sup>	MAX			
$V_{IO}$ Input offset voltage	$V_{CC} = 5\text{ V to MAX,}$ $V_{IC} = V_{ICRmin},$ $V_O = 1.4\text{ V}$	Non-A-suffix devices	25°C	3		7	3		7	mV		
			Full range	10			10					
		A-suffix devices	25°C				1		2			
			Full range				4					
$\Delta V_{IO}/\Delta T$ Input offset voltage temperature drift	$R_S = 0\ \Omega$		Full range				7		$\mu\text{V}/^\circ\text{C}$			
$I_{IO}$ Input offset current	$V_O = 1.4\text{ V}$		25°C	2		50	2		50	nA		
			Full range	300			150					
$\Delta I_{IO}/\Delta T$ Input offset voltage temperature drift			Full range				10		$\text{pA}/^\circ\text{C}$			
$I_{IB}$ Input bias current	$V_O = 1.4\text{ V}$		25°C	-20		-250	-20		-250	nA		
			Full range	-500			-500					
$V_{ICR}$ Common-mode input voltage range	$V_{CC} = 5\text{ V to MAX}$		25°C	0 to $V_{CC} - 1.5$			0 to $V_{CC} - 1.5$			V		
			Full range	0 to $V_{CC} - 2$			0 to $V_{CC} - 2$					
$V_{OH}$ High-level output voltage	$R_L = 2\text{ k}\Omega$ $R_L = 10\text{ k}\Omega$ $V_{CC} = \text{MAX}$		25°C							V		
			25°C	$V_{CC} - 1.5$		$V_{CC} - 1.5$						
		Full range	$R_L = 2\text{ k}\Omega$	22		26						
			$R_L \geq 10\text{ k}\Omega$	23		24		27				
$V_{OL}$ Low-level output voltage	$R_L \leq 10\text{ k}\Omega$		Full range	5		20	5		20	mV		
$A_{VD}$ Large-signal differential voltage amplification	$V_{CC} = 15\text{ V,}$ $V_O = 1\text{ V to }11\text{ V,}$ $R_L \geq 2\text{ k}\Omega$		25°C	25		100	25		100	V/mV		
			Full range	15			15					
CMRR Common-mode rejection ratio	$V_{IC} = V_{ICRmin}$		25°C	50		80	60		80	dB		
$k_{SVR}$ Supply-voltage rejection ratio ( $\Delta V_{CC}/\Delta V_{IO}$ )			25°C	50		100	60		100	dB		
$V_{O1}/V_{O2}$ Crosstalk attenuation	$f = 1\text{ kHz to }20\text{ kHz}$		25°C	120			120			dB		
$I_O$ Output current	$V_{CC} = 15\text{ V,}$ $V_{ID} = 1\text{ V,}$ $V_O = 0$	Source	25°C	-20		-30	-60	-20		-30	-60	mA
			Full range	-10			-10					
	$V_{CC} = 15\text{ V,}$ $V_{ID} = -1\text{ V,}$ $V_O = 15\text{ V}$	Sink	25°C	10		20	10		20			
			Full range	5			5					
	$V_{ID} = -1\text{ V, }V_O = 200\text{ mV}$		25°C	30			12		40	$\mu\text{A}$		
$I_{OS}$ Short-circuit output current	$V_{CC}$ at 5 V, $V_O = 0$ , GND at -5 V		25°C	$\pm 40$		$\pm 60$	$\pm 40$		$\pm 60$	mA		
$I_{CC}$ Supply current (four amplifiers)	$V_O = 2.5\text{ V, No load}$		Full range	0.7		1.2	0.7		1.2	mA		
	$V_{CC} = \text{MAX, }V_O = 0.5 V_{CC},$ No load		Full range	1.4		3	1.4		3			

- (1) All characteristics are measured under open-loop conditions, with zero common-mode input voltage, unless otherwise specified. MAX  $V_{CC}$  for testing purposes is 26 V for XD2902 and 32 V for XL2902.
- (2) Full range is  $-40^\circ\text{C}$  to  $125^\circ\text{C}$  for XD2902.
- (3) All typical values are at  $T_A = 25^\circ\text{C}$ .

# XD124/XD224/XD324/XD2902N DIP14 XL124/XL224/XL324/XL2902 SOP14

## Electrical Characteristics

at specified free-air temperature,  $V_{CC} = 5\text{ V}$  (unless otherwise noted)

PARAMETER	TEST CONDITIONS <sup>(1)</sup>		$T_A$ <sup>(2)</sup>	XD124			XD224			XD324, XL324			UNIT	
				MIN	TYP <sup>(3)</sup>	MAX	MIN	TYP <sup>(3)</sup>	MAX	MIN	TYP <sup>(3)</sup>	MAX		
$V_{IO}$	Input offset voltage	$V_{CC} = 5\text{ V to }30\text{ V},$ $V_{IC} = V_{ICRmin},$ $V_O = 1.4\text{ V}$	25°C			2		2	3		2	3	mV	
			Full range			4		4				5		
$I_{IO}$	Input offset current	$V_O = 1.4\text{ V}$	25°C					2	15		2	30	nA	
			Full range			30		30				75		
$I_{IB}$	Input bias current	$V_O = 1.4\text{ V}$	25°C			-50		-15	-80		-15	-100	nA	
			Full range			-100		-100				-200		
$V_{ICR}$	Common-mode input voltage range	$V_{CC} = 30\text{ V}$	25°C		0 to $V_{CC} - 1.5$		0 to $V_{CC} - 1.5$		0 to $V_{CC} - 1.5$		0 to $V_{CC} - 1.5$		V	
			Full range		0 to $V_{CC} - 2$		0 to $V_{CC} - 2$		0 to $V_{CC} - 2$		0 to $V_{CC} - 2$			
$V_{OH}$	High-level output voltage	$R_L = 2\text{ k}\Omega$ $V_{CC} = 30\text{ V}$	25°C		$V_{CC} - 1.5$		$V_{CC} - 1.5$		$V_{CC} - 1.5$		$V_{CC} - 1.5$		V	
			Full range		26		26		26		26			
$V_{OL}$	Low-level output voltage	$R_L \leq 10\text{ k}\Omega$	25°C					5	20		5	20	mV	
			Full range			20		5	20		5	20		
$A_{VD}$	Large-signal differential voltage amplification	$V_{CC} = 15\text{ V},$ $V_O = 1\text{ V to }11\text{ V},$ $R_L \geq 2\text{ k}\Omega$	25°C		50	100		50	100		25	100	V/mV	
			Full range		25		25		25		15			
CMRR	Common-mode rejection ratio	$V_{IC} = V_{ICRmin}$	25°C		70		70	80		65	80	dB		
$k_{SVR}$	Supply-voltage rejection ratio ( $\Delta V_{CC} / \Delta V_{IO}$ )		25°C		65		65	100		65	100	dB		
$V_{O1} / V_{O2}$	Crosstalk attenuation	$f = 1\text{ kHz to }20\text{ kHz}$	25°C		120		120			120		dB		
$I_O$	Output current	$V_{CC} = 15\text{ V},$ $V_{ID} = 1\text{ V},$ $V_O = 0$	Source	25°C		-20		-20	-30	-60	-20	-30	-60	mA
				Full range		-10		-10		-10		-10		
		$V_{CC} = 15\text{ V},$ $V_{ID} = -1\text{ V},$ $V_O = 15\text{ V}$	Sink	25°C		10		10	20		1	20		
				Full range		5		5		5		5		
$V_{ID} = -1\text{ V}, V_O = 200\text{ mV}$		25°C		12		12	30		12	30	$\mu\text{A}$			
$I_{OS}$	Short-circuit output current	$V_{CC}$ at 5 V, GND at -5 V, $V_O = 0$	25°C		$\pm 40$	$\pm 60$		$\pm 40$	$\pm 60$		$\pm 40$	$\pm 60$	mA	
$I_{CC}$	Supply current (four amplifiers)	$V_O = 2.5\text{ V},$ No load	Full range		0.7	1.2		0.7	1.2		0.7	1.2	mA	
		$V_{CC} = 30\text{ V}, V_O = 15\text{ V},$ No load	Full range		1.4	3.		1.4	3		1.4	3		

- (1) All characteristics are measured under open-loop conditions, with zero common-mode input voltage, unless otherwise specified.  
(2) Full range is  $-55^\circ\text{C}$  to  $125^\circ\text{C}$  for XD124A,  $-25^\circ\text{C}$  to  $85^\circ\text{C}$  for XD224, and  $0^\circ\text{C}$  to  $70^\circ\text{C}$  for XD324.  
(3) All typical values are at  $T_A = 25^\circ\text{C}$ .

# XD124/XD224/XD324/XD2902N DIP14 XL124/XL224/XL324/XL2902 SOP14

## Operating Conditions

$V_{CC} = \pm 15\text{ V}$ ,  $T_A = 25^\circ\text{C}$

PARAMETER	TEST CONDITIONS	TYP	UNIT
SR Slew rate at unity gain	$R_L = 1\text{ M}\Omega$ , $C_L = 30\text{ pF}$ , $V_I = \pm 10\text{ V}$ (see Figure 1)	0.5	$\text{V}/\mu\text{s}$
$B_1$ Unity-gain bandwidth	$R_L = 1\text{ M}\Omega$ , $C_L = 20\text{ pF}$ (see Figure 1)	1.2	MHz
$V_n$ Equivalent input noise voltage	$R_S = 100\ \Omega$ , $V_I = 0\text{ V}$ , $f = 1\text{ kHz}$ (see Figure 2)	35	$\text{nV}/\sqrt{\text{Hz}}$

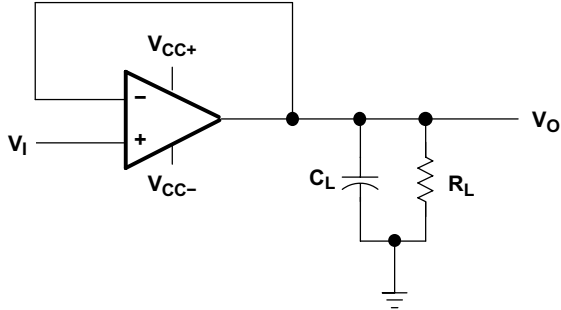

Figure 1. Unity-Gain Amplifier

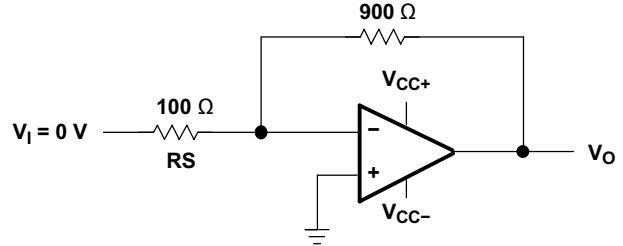

Figure 2. Noise-Test Circuit

以上信息仅供参考. 如需帮助联系客服人员。谢谢 XINLUDA

XD124/XD224/XD324/XD2902N DIP14

XL124/XL224/XL324/XL2902 SOP14

DIP14

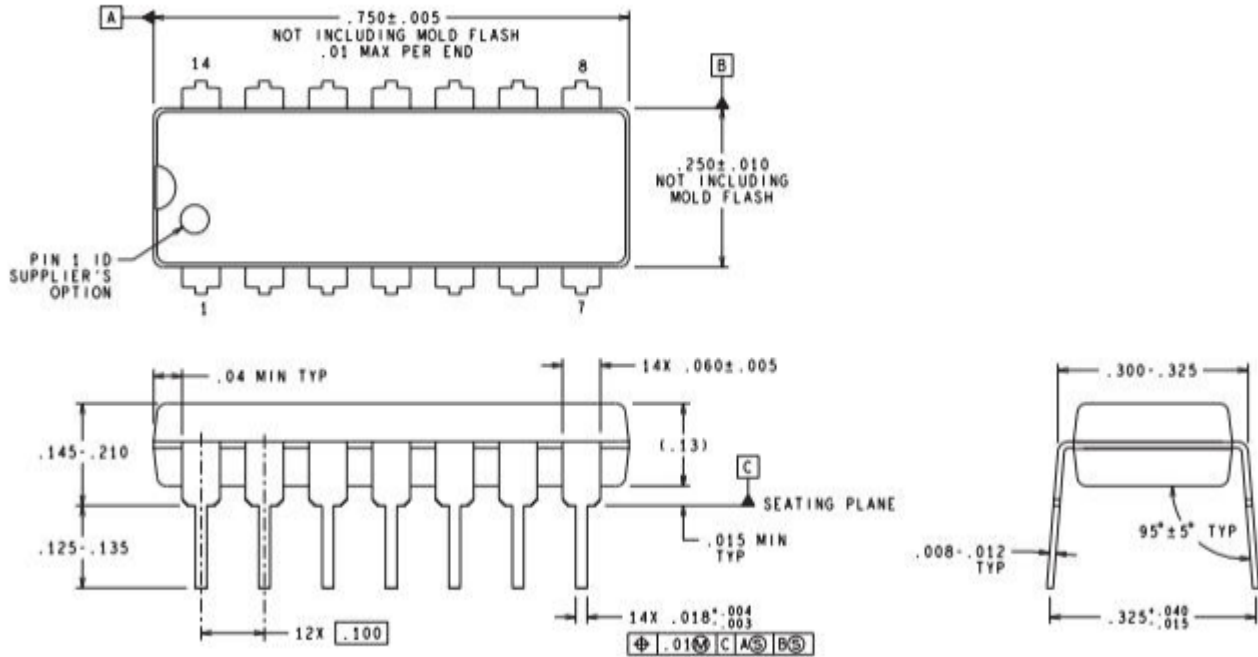

**DIMENSIONS ARE IN INCHES**  
DIMENSIONS IN ( ) FOR REFERENCE ONLY



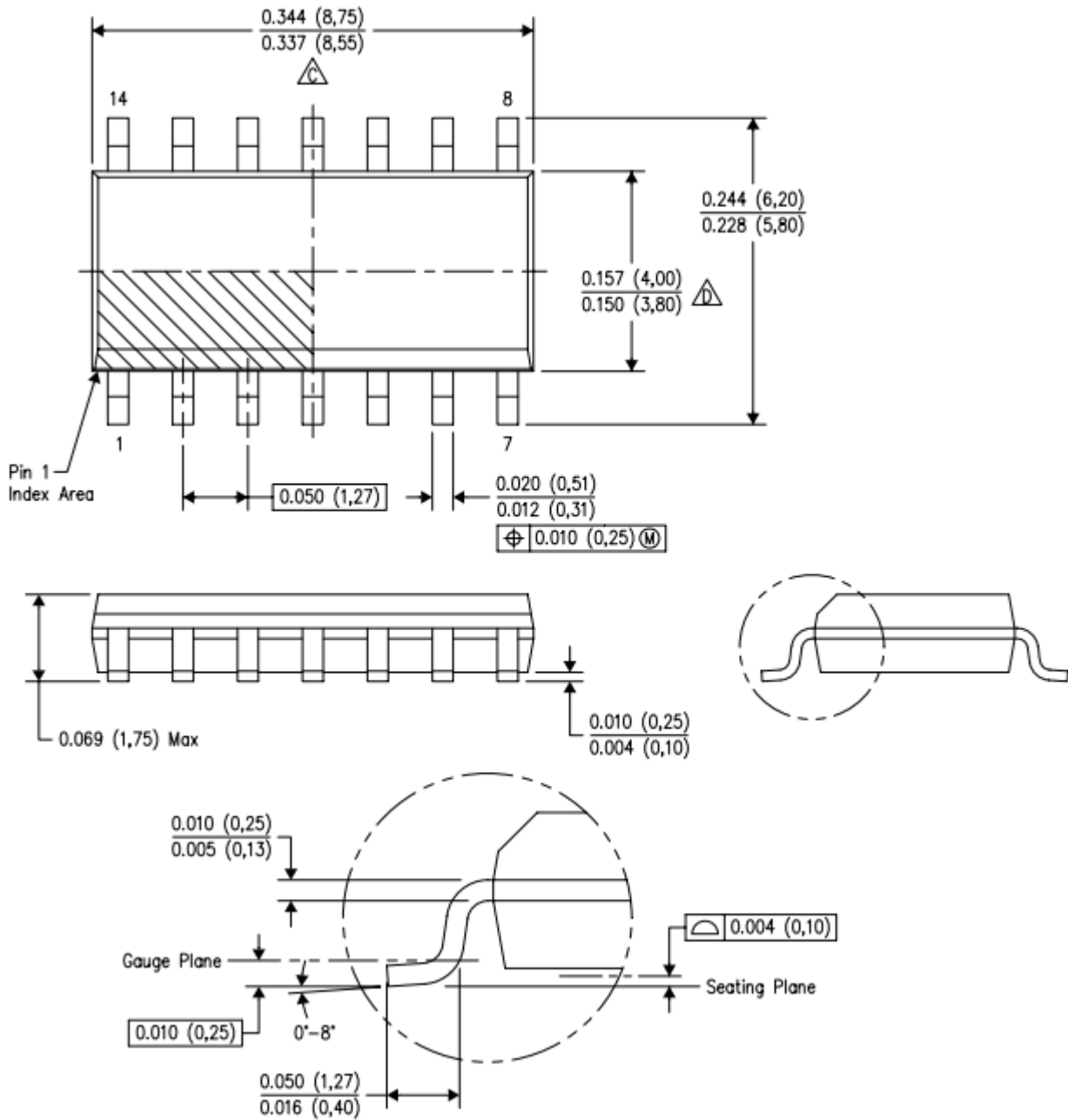

以上信息仅供参考. 如需帮助联系客服人员。谢谢 XINLUDA