



## Reset, Low Voltage Detector Built-in Delay 200mS

### General Description

LP3808 is a series of high precision voltage detector with ultra low current consumption (5uA typ. at Vdd=3.0V). It can work at very low voltage, which makes it perfect for system reset.

LP3808 is composed of high precision voltage reference, comparator, delay circuit, output driver and resistor array. Internally preset detect voltage has a low temperature drift and requires no external trimming.

Two type of output, CMOS and N-channel open-drain are available. LP3808 is available in SOT-23-3 packages which is Pb free.

### Order Information

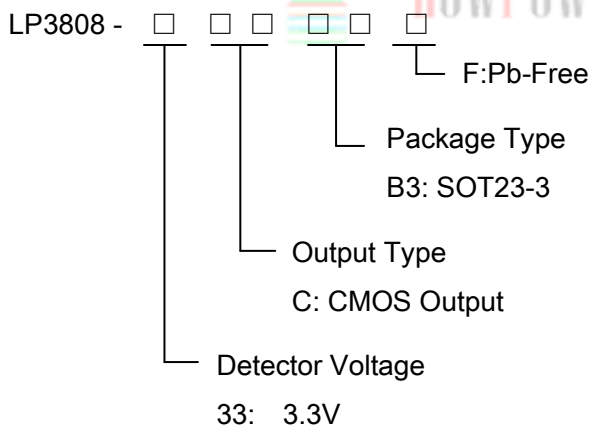

### Features

- ◆ High-precision detection Voltage 2%
- ◆ Detection Voltage 0.9V~5.5V (in 0.1V steps)
- ◆ Precise hysteresis 4% typ.
- ◆ Operating Voltage range 2.5V~5.5V
- ◆ Ultra-low current consumption 5uA typ. (at VDD 3.0V)
- ◆ Two Output forms CMOS and N-channel open-drain

### Applications

- ◇ Power monitor for portable equipment
- ◇ PDA, DSC, Mobile phone, Notebook, MP3
- ◇ CPU and Logic Circuit Reset
- ◇ Battery Checker
- ◇ Battery Back-up Circuit
- ◇ Power Failure Detector



### Pin Assignment

Package Type	Pin Configurations
SOT23-3	

### Pin Description

Pin Number	Pin Name	Function
1	VOUT	Voltage Detection output Pin.
2	VSS	GND pin.
3	VDD	Voltage input pin.

### Block Diagram

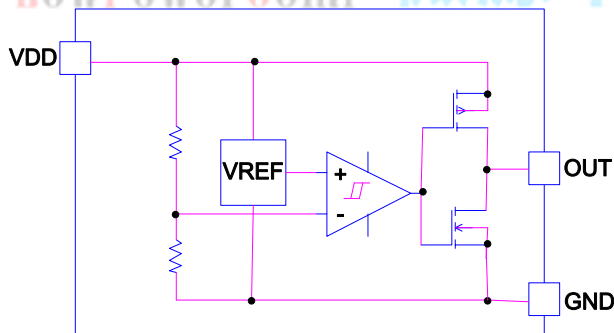

CMOS Output Type



## Absolute Maximum Ratings

- ◇ Input Voltage range ----- -0.3V~6V
- ◇ Output Voltage range ----- -0.3V~6V
- ◇ Maximum Output current ----- 70mA
- ◇ Maximum power dissipation ----- 150mW
- ◇ Ambient temperature ----- -40~+85 C
- ◇ Storage temperature ----- -40~125 C
- ◇ Lead temperature and time ----- 260°C,10S

## Electrical Characteristics

(LP3808-33B3F, T=25°C, Unless otherwise specified.)

Symbol	Parameter	Conditions	Reference data			Unit
			Min.	Typ.	Max.	
VDET	Detector Threshold			3.3		V
VHYS	Detector Threshold Hysteresis		0.054	0.108	0.162	V
ISS	Current consumption			5		uA
VDDH	Maximum operating voltage				5.5	V
VDDL	Minimum Operating voltage			2.5		V
IOUT	Output current	Nch VDS=0.05V VDD=0.70V	0.01	0.05		mA
		Pch VDS=-2.1V VDD=4.50V	1.0	2.0		mA
TDELAY	Output Delay Time			200		mS



### Packaging Information

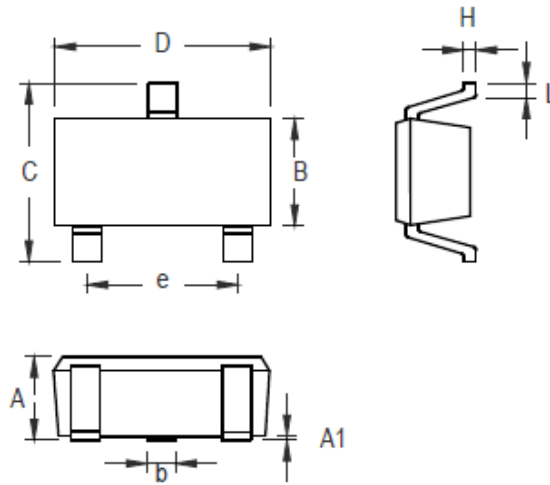

Symbol	Dimensions In Millimeters		Dimensions In Inches	
	Min	Max	Min	Max
A	0.889	1.295	0.035	0.051
A1	0.000	0.152	0.000	0.006
B	1.397	1.803	0.055	0.071
b	0.356	0.508	0.014	0.020
C	2.591	2.997	0.102	0.118
D	2.692	3.099	0.106	0.122
e	1.803	2.007	0.071	0.079
H	0.080	0.254	0.003	0.010
L	0.300	0.610	0.012	0.024

**SOT-23 Surface Mount Package**