

◆贴片型 产品型号体系/CHIP TYPE PART NUMBER

□□□ 额定电压 Rated Voltage	□□□□ 系列名称 Series	□□□□□ 静电容量 Capacitance	□ 静电容量允许差 Capacitance Tolerance	□□□ 副记号 Option ※1	D×L 铝壳尺寸 Case Size																									
<table border="1" style="width: 100%; border-collapse: collapse;"> <thead> <tr> <th>Rated Voltage (Vdc)</th> <th>Code</th> </tr> </thead> <tbody> <tr><td>6.3</td><td>6.3</td></tr> <tr><td>10</td><td>10</td></tr> <tr><td>25</td><td>25</td></tr> <tr><td>100</td><td>100</td></tr> </tbody> </table>	Rated Voltage (Vdc)	Code	6.3	6.3	10	10	25	25	100	100		<table border="1" style="width: 100%; border-collapse: collapse;"> <thead> <tr> <th>Cap. (μF)</th> <th>Code</th> </tr> </thead> <tbody> <tr><td>4.7</td><td>4R7</td></tr> <tr><td>220</td><td>220</td></tr> <tr><td>3300</td><td>3300</td></tr> </tbody> </table>	Cap. (μF)	Code	4.7	4R7	220	220	3300	3300	<table border="1" style="width: 100%; border-collapse: collapse;"> <thead> <tr> <th>Tolerance</th> <th>Code</th> </tr> </thead> <tbody> <tr><td>±20%</td><td>M</td></tr> </tbody> </table>	Tolerance	Code	±20%	M		<table border="1" style="width: 100%; border-collapse: collapse;"> <tbody> <tr><td>4×6.1</td></tr> <tr><td>8×10.5</td></tr> <tr><td>16×21.5</td></tr> </tbody> </table>	4×6.1	8×10.5	16×21.5
Rated Voltage (Vdc)	Code																													
6.3	6.3																													
10	10																													
25	25																													
100	100																													
Cap. (μF)	Code																													
4.7	4R7																													
220	220																													
3300	3300																													
Tolerance	Code																													
±20%	M																													
4×6.1																														
8×10.5																														
16×21.5																														
在订货时，请注明额定电压、系列名称、静电容量、铝壳尺寸的信息。 Please indicate the above information, when ordering.																														
例) : Example																														
35	TZV	330	M		10×10.5																									

※1 副记号：标准品为空白。
 Option : Standard item is blank.

◆引线型 产品型号体系/LEAD WIRE TYPE PART NUMBER

□□□ 额定电压 Rated Voltage	□□□□ 系列名称 Series	□□□□□ 静电容量 Capacitance	□ 静电容量允许差 Capacitance Tolerance	□□□ 副记号 Option ※2	□□ 引线加工记号 Lead Forming ※3	D×L 铝壳尺寸 Case Size																																	
<table border="1" style="width: 100%; border-collapse: collapse;"> <thead> <tr> <th>Rated Voltage (Vdc)</th> <th>Code</th> </tr> </thead> <tbody> <tr><td>6.3</td><td>6.3</td></tr> <tr><td>10</td><td>10</td></tr> <tr><td>25</td><td>25</td></tr> <tr><td>100</td><td>100</td></tr> </tbody> </table>	Rated Voltage (Vdc)	Code	6.3	6.3	10	10	25	25	100	100		<table border="1" style="width: 100%; border-collapse: collapse;"> <thead> <tr> <th>Cap. (μF)</th> <th>Code</th> </tr> </thead> <tbody> <tr><td>0.1</td><td>0R1</td></tr> <tr><td>0.47</td><td>0R47</td></tr> <tr><td>1</td><td>1</td></tr> <tr><td>10</td><td>10</td></tr> <tr><td>1000</td><td>1000</td></tr> </tbody> </table>	Cap. (μF)	Code	0.1	0R1	0.47	0R47	1	1	10	10	1000	1000	<table border="1" style="width: 100%; border-collapse: collapse;"> <thead> <tr> <th>Tolerance</th> <th>Code</th> </tr> </thead> <tbody> <tr><td>±20%</td><td>M</td></tr> </tbody> </table>	Tolerance	Code	±20%	M	<table border="1" style="width: 100%; border-collapse: collapse;"> <tbody> <tr><td>EFC</td></tr> <tr><td>etc</td></tr> </tbody> </table>	EFC	etc	<table border="1" style="width: 100%; border-collapse: collapse;"> <tbody> <tr><td>TA, KC,</td></tr> <tr><td>CA etc</td></tr> </tbody> </table>	TA, KC,	CA etc	<table border="1" style="width: 100%; border-collapse: collapse;"> <tbody> <tr><td>5×11</td></tr> <tr><td>10×12.5</td></tr> <tr><td>12.5×40</td></tr> </tbody> </table>	5×11	10×12.5	12.5×40
Rated Voltage (Vdc)	Code																																						
6.3	6.3																																						
10	10																																						
25	25																																						
100	100																																						
Cap. (μF)	Code																																						
0.1	0R1																																						
0.47	0R47																																						
1	1																																						
10	10																																						
1000	1000																																						
Tolerance	Code																																						
±20%	M																																						
EFC																																							
etc																																							
TA, KC,																																							
CA etc																																							
5×11																																							
10×12.5																																							
12.5×40																																							
在订货时，请注明额定电压、系列名称、静电容量、引线加工、铝壳尺寸的信息。 Please indicate the above information, when ordering.																																							
例) : Example																																							
• 长引线品 Long lead type	50	PX	2R2	M	EFC	5×11																																	
• 编带品 Taping type	35	ZLJ	220	M	TA	8×16																																	

※2 副记号：请确认各系列的页面。
 Option : Please confirm each series page.

※3 引线加工记号：请参照编带规格及引线加工规格的项目。
 Lead Forming : Please refer to TAPING SPECIFICATIONS and LEAD CUTTING FORMING SPECIFICATIONS.



小型铝电解电容器

MINIATURE ALUMINUM ELECTROLYTIC CAPACITORS

包装规格/PACKAGING SPECIFICATION

◆引线端子型/LEAD WIRE TYPE

Q'ty (pcs)

产品尺寸 SIZE (mm)	长引线品 LONG LEAD		引线加工品 LEAD FORMING		编带品 TAPING	
	散装 BULK PACKAGE	盒装 ALIGNED PACKAGE	散装 BULK PACKAGE	盒装 ALIGNED PACKAGE		
φ4	4×5	5,000	—	5,000	—	2,000
	4×7	5,000	—	5,000	—	2,000
φ5	5×5	5,000	—	5,000	—	2,000
	5×7	5,000	—	5,000	—	2,000
	5×11	3,000	—	5,000	—	2,000
φ6.3	6.3×5	3,000	—	5,000	—	2,000
	6.3×7	3,000	—	5,000	—	2,000
	6.3×9	2,000	—	3,000	—	2,000
	6.3×11	2,000	—	3,000	—	2,000
	6.3×14	2,000	—	3,000	—	2,000
	6.3×25	1,000	—	1,000	—	—
	6.3×30	1,000	—	1,000	—	—
	6.3×40	1,000	—	1,000	—	—
φ8	8×5	3,000	—	5,000	—	1,000
	8×7	3,000	—	5,000	—	1,000
	8×7.5	2,000	—	2,000	—	1,000
	8×9	2,000	—	2,000	—	1,000
	8×10.8	2,000	—	2,000	—	1,000
	8×11.5	2,000	—	2,000	—	1,000
	8×16	1,000	—	1,000	—	1,000
	8×20	1,000	—	1,000	—	1,000
	8×23	1,000	—	1,000	—	1,000
	8×25	—	500	—	500	—
	8×30	—	500	—	500	—
	8×35	—	500	—	500	—
	8×40	—	500	—	500	—
	8×45	—	500	—	500	—
	8×50	—	500	—	500	—
	8×55	—	500	—	500	—
8×60	—	500	—	500	—	
φ10	10×9	1,000	—	1,000	—	500
	10×10	1,000	—	1,000	—	500
	10×12.5	1,000	—	1,000	—	500
	10×16	1,000	—	1,000	—	500
	10×20	1,000	—	1,000	—	500
	10×23	1,000	—	1,000	—	500
	10×25	1,000	500	1,000	500	500
	10×28	1,000	500	1,000	500	500
	10×30	—	500	—	500	—
	10×35	—	500	—	500	—
	10×40	—	500	—	500	—
	10×45	—	500	—	500	—
	10×50	—	500	—	500	—
	10×55	—	500	—	500	—
10×60	—	500	—	500	—	

产品尺寸 SIZE (mm)	长引线品 LONG LEAD		引线加工品 LEAD FORMING		编带品 TAPING	
	散装 BULK PACKAGE	盒装 ALIGNED PACKAGE	散装 BULK PACKAGE	盒装 ALIGNED PACKAGE		
φ12.5	12.5×16	1,000	—	1,000	500	500
	12.5×20	1,000	500	1,000	500	500
	12.5×25	1,000	500	1,000	500	500
	12.5×30	600	500	600	500	500
	12.5×35	600	500	600	500	500
	12.5×40	600	500	600	500	500
	12.5×45	—	500	—	500	—
	12.5×50	—	500	—	500	—
	12.5×55	—	500	—	500	—
	12.5×60	—	500	—	500	—
φ14.5	14.5×20	—	500	—	500	—
	14.5×25	—	500	—	500	—
	14.5×30	—	500	—	500	—
	14.5×31.5	—	500	—	500	—
	14.5×35	—	500	—	500	—
	14.5×40	—	500	—	500	—
φ16	14.5×45	—	500	—	500	—
	14.5×50	—	500	—	500	—
	16×16	600	—	600	400	250
	16×20	600	200	600	400	250
	16×25	600	200	600	400	250
	16×30	—	200	—	200	250
	16×31.5	—	200	—	200	250
	16×35	—	200	—	200	250
	16×35.5	—	200	—	200	250
	16×40	—	200	—	200	250
φ18	16×45	—	200	—	200	—
	16×50	—	200	—	200	—
	18×16	500	—	—	200	250
	18×20	500	200	—	200	250
	18×25	500	200	—	200	250
	18×30	—	200	—	200	250
	18×31.5	—	200	—	200	250
	18×35	—	200	—	200	250
	18×35.5	—	200	—	200	250
	18×40	—	200	—	200	250
18×45	—	200	—	200	—	
18×50	—	200	—	200	—	

- 包装单位存在与上述相异的情况。
There are some differences between actual package quantity and above list.
- 关于散装与盒装并记的尺寸，以盒装作为出口用的标准。
For the sizes stated both bulk and aligned package, aligned package is standard for exporting carton.

◆ 编带规格 / TAPING SPECIFICATIONS

◆ 纵向引线形 (04形) 编带形状尺寸图 / DIMENSIONS

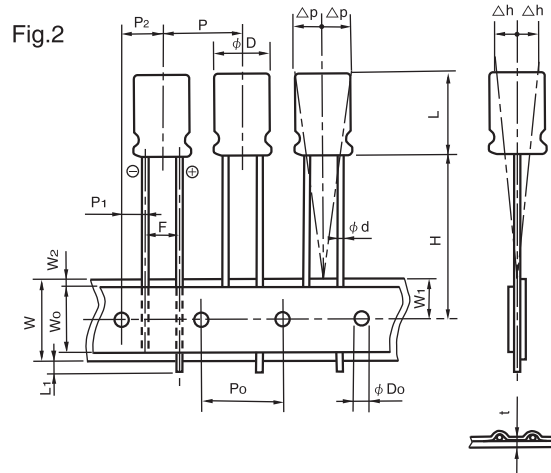
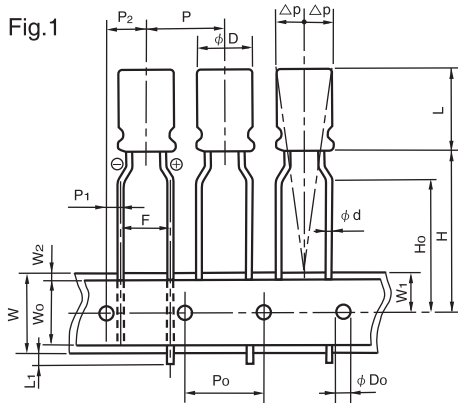

◆ 规格表 / SPECIFICATION TABLE

(mm)

项 目 Items	记 号 Code	5mm Height		7mm or 7.5mm Height				允许差 Tolerance
		$\phi 4 \sim \phi 8$		$\phi 4 \sim \phi 6.3$	$\phi 4 \sim \phi 6.3$	$\phi 8$		
引线加工记号 Taping code		T5	TZ	T5	TZ	TA	T7	
形状尺寸图 Applicable Fig. No.		Fig.2	Fig.1	Fig.2	Fig.1	Fig.1	Fig.2	
引线直径 Dia. of lead	ϕd	0.45		0.45				± 0.05
主体高度 Height of body	L	6.5		8.5				MAX
主体间距 Distance from center to center of next body	P	12.7		12.7				± 1.0
穿孔间距 Distance from center to center of next driving hole	P ₀	12.7		12.7				± 0.2
穿孔与引线间距 Distance between center of driving hole and lead	P ₁	5.1	3.85	5.1	3.85	4.6		± 0.5
穿孔与主体间距 Distance between center of driving hole and body	P ₂	6.35		6.35				± 1.0
引线间距 Pitch of lead	F	2.5	5.0	2.5	5.0	3.5		+0.8 -0.2
衬纸宽度 Width of mounting tape	W	18.0		18.0				± 0.3
胶带宽度 Width of adhesive tape	W ₀	5.0		5.0				MIN
穿孔与衬纸间距 Distance between center of driving hole and mounting tape edge	W ₁	9.0		9.0				± 0.5
胶带与衬纸间距 Max. allowable distance between mounting and adhesive tape edges	W ₂	1.5		1.5				MAX
主体下方位置 Distance between center of driving hole and bottom of body	H	17.5		17.5		20.0		± 0.75
引线弯曲高度 Distance between center of driving hole and clinch part of lead	H ₀	—	16.0	—	16.0		—	± 0.5
引线头 End of lead	L ₁	0.5		0.5				MAX
穿孔直径 Dia. of driving hole	ϕD_0	4.0		4.0				± 0.2
主体倾斜度 Off alignment of body top	Δh	1.0		1.0				MAX
主体倾斜度 Off alignment of body top	Δp	1.0		1.0				MAX
编带总厚度 Sum of thickness for mounting and adhesive tape without lead dia	t	0.6		0.6				± 0.3
包装数量 (个) Quantity (pcs)		2000 ($\phi 8:1000$)						

Fig.3

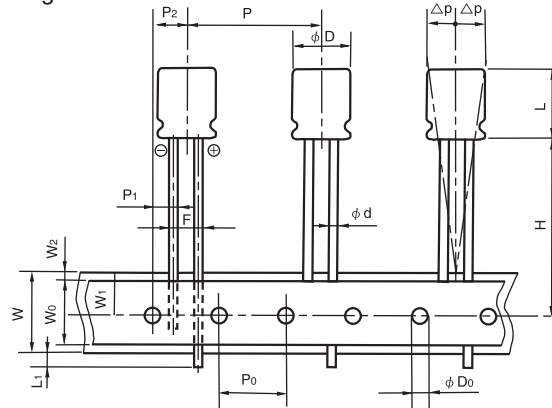

规格表 / SPECIFICATION TABLE

(mm)

项 目 Items	记 号 Code	9mm or more Height						※ 允许差 Tolerance		
		φ 5, φ 6.3		φ 8	φ 10	φ 12.5	φ 16		φ 18	
引线加工记号 Taping code		T1	TA	TA	T7	T8	G4	GC		
形状尺寸图 Applicable Fig. No.		Fig.2	Fig.1	Fig.1	Fig.2	Fig.2	Fig.2	Fig.3		
引线直径 Dia. of lead	φ d	0.5		0.6			0.8		±0.05	
主体高度 Height of body	L	13.0		22.0		30.0	42.0		MAX	
主体间距 Distance from center to center of next body	P	12.7			15.0		30.0		±1.0	
穿孔间距 Distance from center to center of next driving hole	P ₀	12.7			15.0		15.0±0.3		±0.2	
穿孔与引线间距 Distance between center of driving hole and lead	P ₁	5.1	3.85	4.6	3.85	5.0	3.75		±0.5	
穿孔与主体间距 Distance between center of driving hole and body	P ₂	6.35			7.5				±1.0	
引线间距 Pitch of lead	F	2.5	5.0	3.5	5.0±0.8		7.5±0.8		+0.8 -0.2	
衬纸宽度 Width of mounting tape	W	18.0							±0.3	
胶带宽度 Width of adhesive tape	W ₀	5.0							MIN	
穿孔与衬纸间距 Distance between center of driving hole and mounting tape edge	W ₁	9.0							±0.5	
胶带与衬纸间距 Max. allowable distance between mounting and adhesive tape edges	W ₂	1.5							MAX	
主体下方位置 Distance between center of driving hole and bottom of body	H	18.5		20.0		18.5 ^{+0.75} _{-0.5}			±0.75	
引线弯曲高度 Distance between center of driving hole and clinch part of lead	H ₀	—	16.0		—	—			±0.5	
引线头 End of lead	L ₁	0.5							MAX	
穿孔直径 Dia. of driving hole	φ D ₀	4.0							±0.2	
主体倾斜度 Off alignment of body top	△h	1.0							MAX	
主体倾斜度 Off alignment of body top	△p	1.0							MAX	
编带总厚度 Sum of thickness for mounting and adhesive tape without lead dia	t	0.6							±0.3	
包装数量 (个) Quantity (pcs)		2000		1000		500		250		

※容许差有特别规定时，特别规定优先。

※For the case that tolerance is specified individually, the value shall have the priority.

◆引线加工规格 / LEAD CUTTING FORMING SPECIFICATIONS

为了使产品在印刷电路板上安装方便，我公司对产品引线有以下加工类型：引线成型，引线切脚，基板自立型特殊加工（爪式引线成型）。Rubycon provides lead-formed and lead-cut products to facilitate mounting on printed circuit boards, as well as products with leads specially processed (kink formed) for self supporting insertions to printed circuit boards.

• 引线成型
Lead forming

($\phi 5 \sim \phi 8$)
Lead forming code : FA

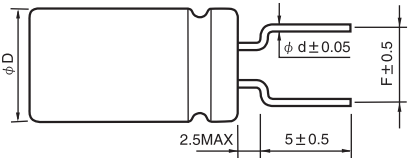

(mm)			
ϕD	5	6.3	8
ϕd	0.5		0.6
F	5.0		

• 引线切脚
Lead cutting

($\phi 5 \sim \phi 18$)
Lead cutting code : CA
CC
CE

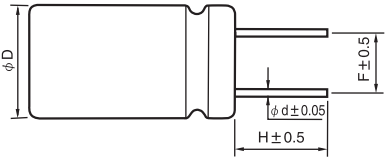

(mm)								
ϕD	5	6.3	8	10	12.5	14.5	16	18
H	5.0 (CA)							
	4.0 (CC)							
	3.5 (CE)							
ϕd	0.5		0.6		0.8			
F	2.0	2.5	3.5	5.0		7.5		

• 爪式引线成型
Kinked lead forming

($\phi 5 \sim \phi 8$)
Kinked lead forming code : KC

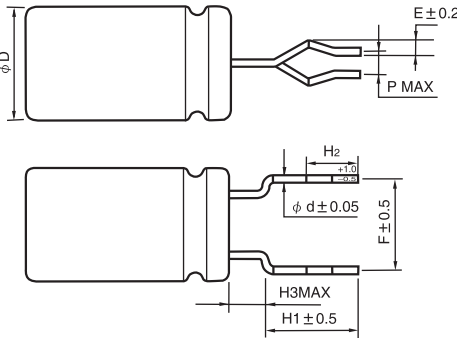

(mm)								
ϕD	5	6.3	8	10	12.5	14.5	16	18
H1	4.5							
H2	2.8							
H3	2.5		—					
F	5.0				7.5			
P	1.0							
E	1.2			1.3				
ϕd	0.5		0.6		0.8			

• 爪式引线切脚
Kinked lead cutting

($\phi 10 \sim \phi 18$)
Kinked lead cutting code : KC

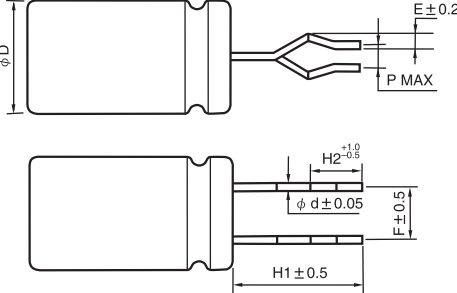

(mm)								
ϕD	5	6.3	8	10	12.5	14.5	16	18
H1	4.5							
H2	2.8							
H3	2.5		—					
F	5.0				7.5			
P	1.0							
E	1.2			1.3				
ϕd	0.5		0.6		0.8			

• 横置对应品 ($\phi 10 \sim \phi 18$) / Low profile with horizontal mounting

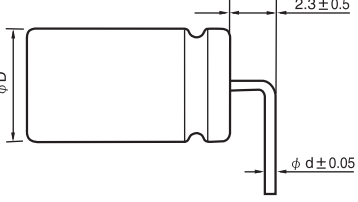

A型 Type A

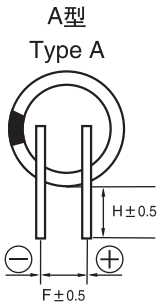

B型 Type B

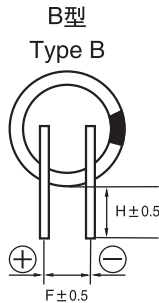

(mm)								
ϕD	10, 12.5				14.5, 16, 18			
Code	RI	RK	RX	SG	RI	RK	RX	SG
ϕd	0.6				0.8			
F	5.0				7.5			
H	4.0		3.5		4.0		3.5	
Type	A	B	A	B	A	B	A	B