

» **Features**

- 350 Watts peak pulse power ($t_p = 8/20\mu s$)
- Unidirectional configurations
- Solid-state silicon-avalanche technology
- Low clamping voltage
- Low leakage current
- IEC 61000-4-2 $\pm 8kV$ contact $\pm 15kV$ air
- IEC 61000-4-4 (EFT) 40A (5/50ns)
- IEC 61000-4-5 (Lightning) 22A (8/20 μs)

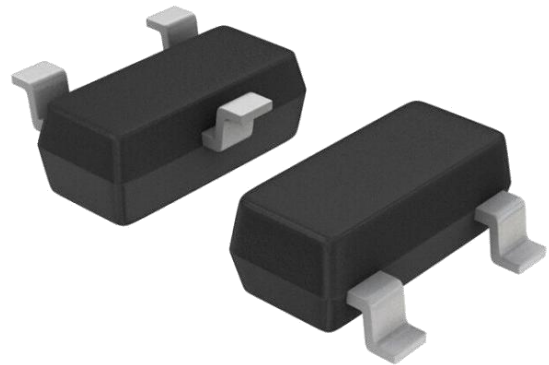

» **Applications**

- Dataline
- Automatic Teller Machines
- Net works
- Power line

» **Mechanical Data**

- SOT-23 package
- Molding compound flammability rating: UL 94V-0
- Packaging: Tape and Reel
- RoHS/WEEE Compliant

» **Schematic & PIN Configuration**

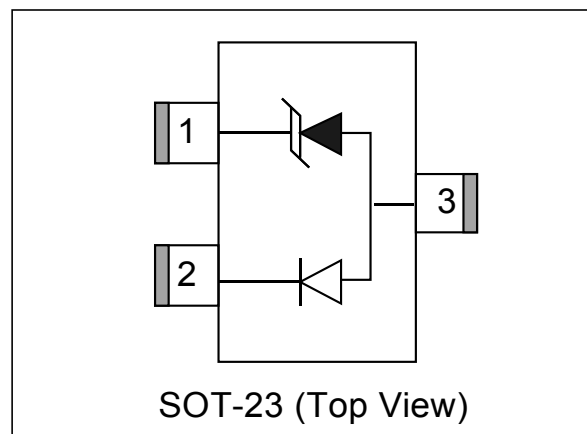
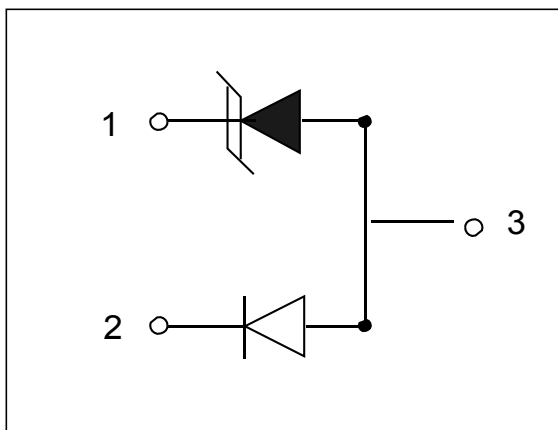

» **Absolute Maximum Rating**

Rating	Symbol	Value	Units
Peak Pulse Power ($t_p=8/20\mu s$)	P_{PP}	350	Watts
Peak Pulse Current ($t_p=8/20\mu s$) (note1)	I_{pp}	22	A
ESD per IEC 61000-4-2 (Air) ESD per IEC 61000-4-2 (Contact)	V_{ESD}	15 8	kV
Lead Soldering Temperature	T_L	260(10seconds)	°C
Junction Temperature	T_J	-55 to + 125	°C
Storage Temperature	T_{stg}	-55 to + 125	°C

» **Electrical Characteristics**

Parameter	Symbol	Conditions	Min	Typical	Max	Units
Reverse Stand-Off Voltage	V_{RWM}				5.0	V
Reverse Breakdown Voltage	V_{BR}	$I_T=1mA$	6.0			V
Reverse Leakage Current	I_R	$V_{RWM}=5V, T=25^\circ C$		0.1	0.5	μA
Peak Pulse Current	I_{pp}	$t_p=8/20\mu s$			22	A
Clamping Voltage	V_C	$I_{pp}=22A, t_p=8/20\mu s$			17	V
Junction Capacitance	C_j	$V_R=0V, f=1MHz$		0.5		pF

» **Electrical Parameters (TA = 25°C unless otherwise noted)**

Symbol	Parameter
I_{PP}	Maximum Reverse Peak Pulse Current
V_C	Clamping Voltage @ I_{PP}
V_{RWM}	Working Peak Reverse Voltage
I_R	Maximum Reverse Leakage Current @ V_{RWM}
V_{BR}	Breakdown Voltage @ I_T
I_T	Test Current

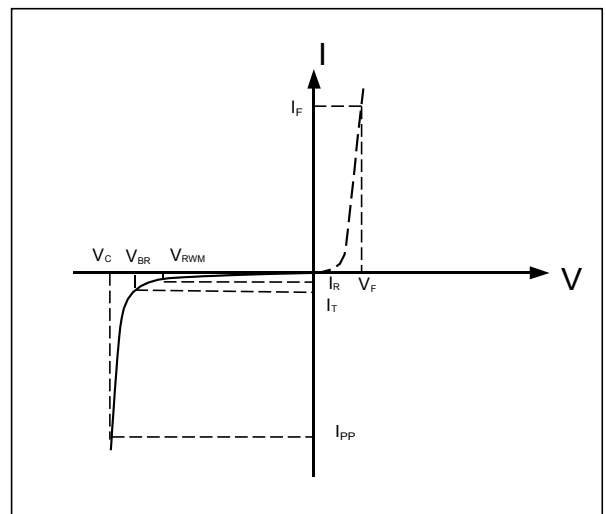

Note: 8/20 μs pulse waveform.

» Typical Characteristics

Figure 1: Peak Pulse Power vs. Pulse Time

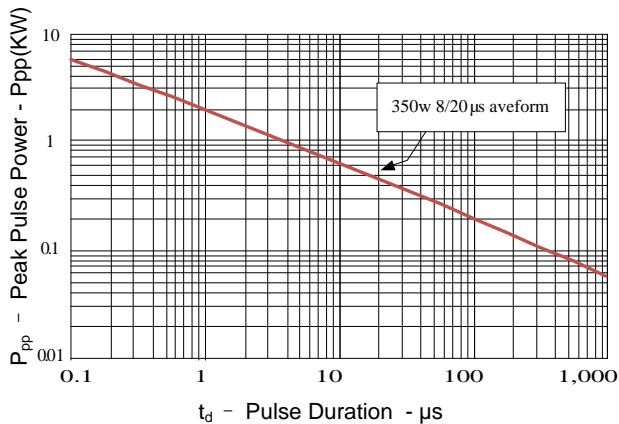

Figure 2: Power Derating Curve

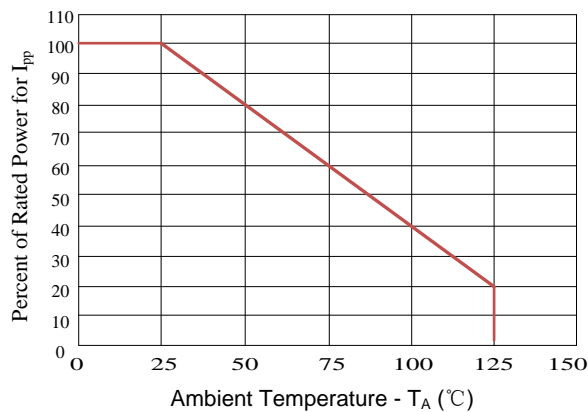

Figure3: Pulse Waveform

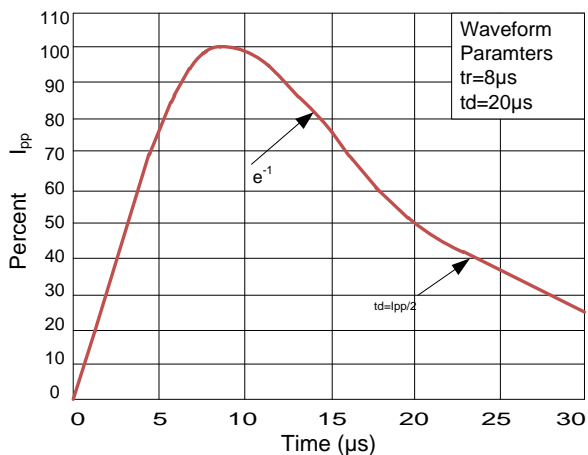
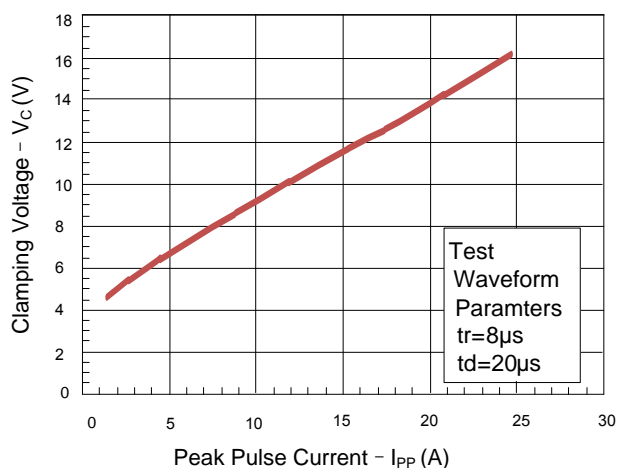

Figure 4: Clamping Voltage vs. Ipp



» Application Information

The BS05L series devices are designed to protect high speed data lines. The MES05L utilizes a low capacitance compensation diode in series with, but in opposite polarity to a TVS diode in each line to achieve an effective capacitance of less than 0.5pF per device. During a transient event, the internal rectifier must be forward biased (TVS is reversed biased). Therefore, each device will only suppress transient events in one polarity. To achieve protection in both positive and negative polarity, a second device is connected in anti-parallel to the first. On unidirectional lines, a fast switching steering diode may be used as an alternative to using two BS05L devices.

Protection of one unidirectional or bidirectional high-speed line is achieved by connecting two devices in anti-parallel. Pin 1 of the first device is connected to the line and pin 2 is connected to ground (or to a second line for differential protection). Pin 2 of the second device is connected to line 1 and pin 1 is connected to ground (or line 2) as shown. Pin 3 is not connected.

An alternative solution to protect unidirectional lines, is to connect a fast switching steering diode in parallel with the BSXXL series device. When the steering diode is forward-biased, the TVS will avalanche and conduct in reverse direction. It is important to note that by adding a steering diode, the effective capacitance in the circuit will be increased, therefore the impact of adding a steering diode must be taken in consideration to establish whether the incremental capacitance will affect the circuit functionality or not.

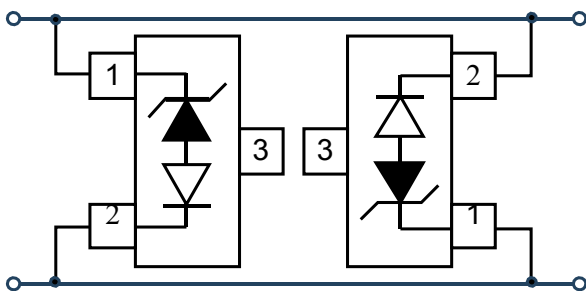

Two Devices: Bidirectional or Unidirectional

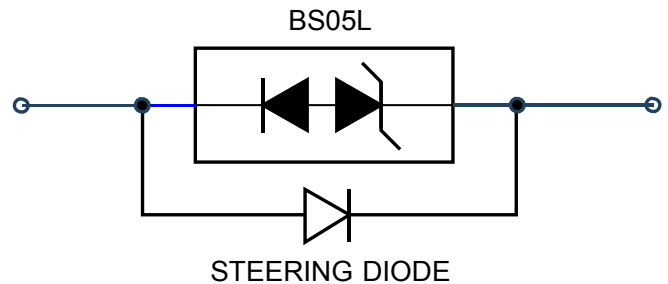

One Device: Unidirectional Line

Another typical application, in which the BS05L series device can be utilized, is to protect multiple I/O lines. The protection in each of the I/O lines is achieved by connecting two devices inverse-parallel

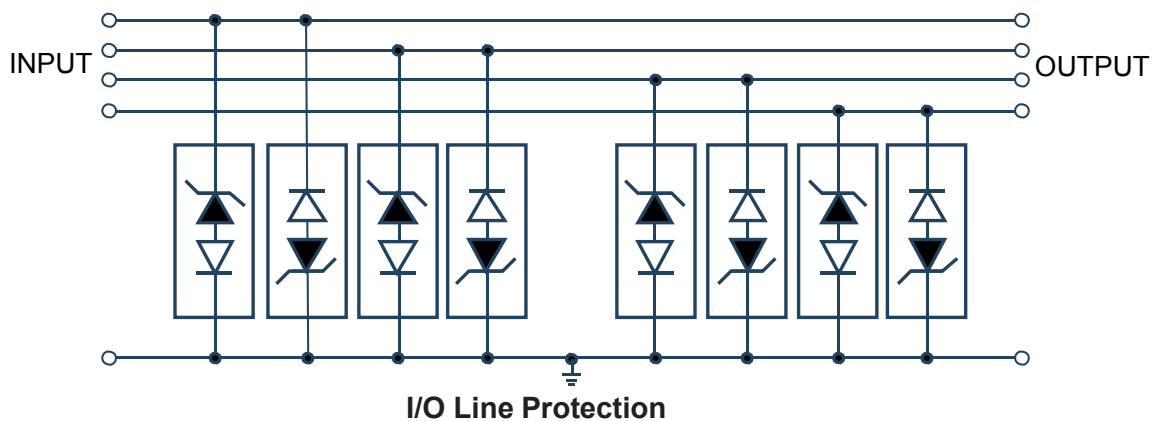

I/O Line Protection

» Outline Drawing – SOT-23

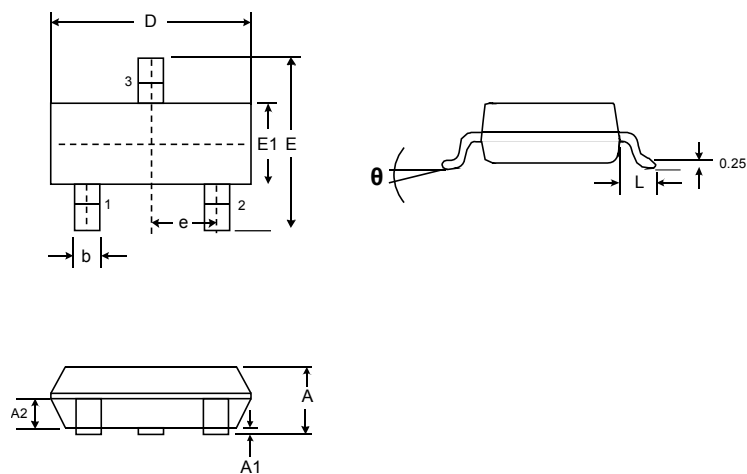

SYMBOL	DIMENSIONS			
	MILLIMETER		INCHES	
	MIN	MAX	MIN	MAX
A	0.89	1.13	0.035	0.044
A1	0.015	0.11	0.0006	0.0043
A2	0.60	0.70	0.0236	0.0275
D	2.72	3.12	0.1070	0.1228
E	2.60	3.00	0.1024	0.118
E1	1.40	1.80	0.0551	0.0709
e	0.95 BSC		0.0374 BSC	
L	0.30	0.60	0.0118	0.0236
θ	0	8°	0	8°

» Marking

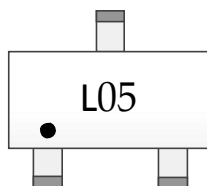

» Ordering information

Order code	Package	Base qty	Delivery mode
BS05L	SOT-23	3k	Tape and reel