



# LC9018

## Low Voltage Detector With Built-in Delay Circuit

### DESCRIPTION

LC9018 is a series of high precision voltage detector with ultra-low current consumption (4.5uA typ. at  $V_{in}=3.0V$ ) and a built-in delay circuit. It can work at very low voltage, which makes it perfect for system reset.

LC9018 is composed of high precision voltage reference, comparator, delay circuit, output driver and resistor array. Internally preset detect voltage has a low temperature drift and requires no external trimming.

Two type of output, CMOS and N-channel open-drain are available.

LC9018 is available in TSOT-23 package which is Pb free.

### FEATURES

- High-precision detection voltage:  $\pm 2\%$
- Detection voltage: 2.63V and 2.93V (customized other voltages)
- Built-in power on reset delay time circuit: Refer to selection guide
- Operating voltage range: 1.2V~6V
- Ultra-low current consumption: 4.5uA typ. (at  $V_{in}=3.0V$ )
- Two output forms: CMOS (active low) and N-channel open-drain (active low)

### APPLICATIONS

- Power monitor for portable equipment such as PDA, DSC, mobile phone, notebook, MP3
- CPU and logic circuit reset
- Battery checker
- Battery back-up circuit
- Power failure detector

### TYPICAL APPLICATION

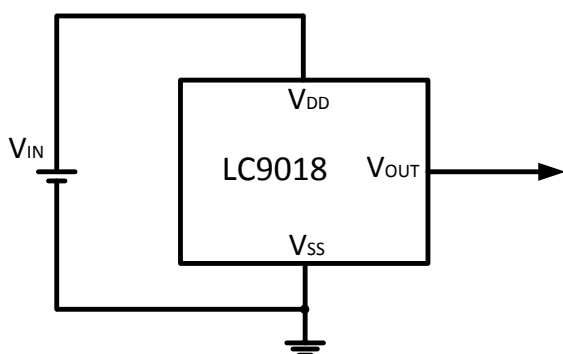

### ELECTRICAL CHARACTERISTICS

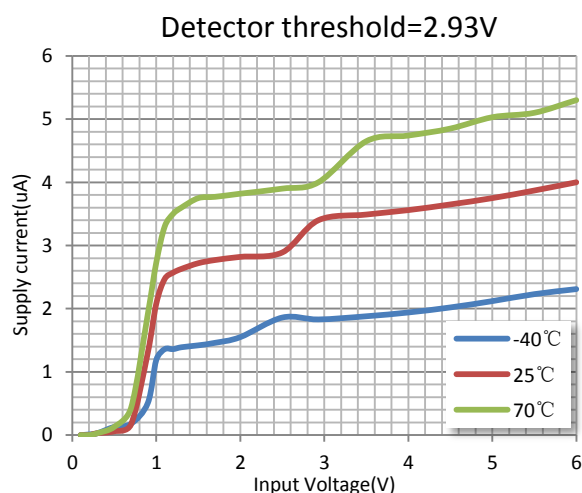

## ORDERING INFORMATION

LC9018 [1](#) [2](#) [3](#) [4](#) [5](#) [6](#)

Code	Description
<a href="#">1</a>	Temperature&Rohs: C:-40~85°C ,Pb Free Rohs Std.
<a href="#">2</a>	Package type: B3:SOT-23-3(A) B3B:SOT-23-3(B)
<a href="#">3</a>	Packing type: TR:Tape&Reel (Standard)
<a href="#">4</a>	Detector voltage: e.g. 263=2.63V 293=2.93V
<a href="#">5</a>	Delay time: D:200mS
<a href="#">6</a>	Output forms: C:CMOS N:Nch

## PIN CONFIGURATION

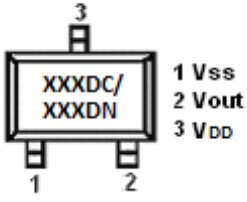
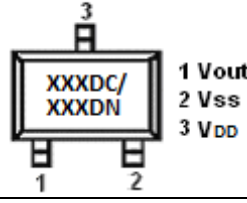
Product classification		LC9018CB3TR□□□
Marking		SOT-23-3 (A)
XXXDC/ XXXDN	XXX: Detector voltage	
	D:Delay time D:200mS	
	C:CMOS N:Nch	
Product classification		LC9018CB3BTR□□□
Marking		SOT-23-3 (B)
XXXDC/ XXXDN	XXX: Detector voltage	
	D:Delay time D:200mS	
	C:CMOS N:Nch	
Vss	Ground pin	
VDD	Supply voltage input	
Vout	Voltage detection output pin	

## ABSOLUTE MAXIMUM RATING

Parameter	Value
Input voltage	-0.3V-8V
Output voltage range	-0.3V- 8V
Maximum output current	70mA
Ambient temperature(T <sub>A</sub> )	-40°C -85°C
Power dissipation	TSOT-23 250mW
Storage temperature(T <sub>S</sub> )	-40°C -150°C
Lead temperature & time	260°C,10S

### Note:

Exceed these limits to damage to the device.

Exposure to absolute maximum rating conditions may affect device reliability.

## RECOMMENDED WORK CONDITIONS

Item	Min	Recommended	Max.	Unit
Input voltage range	1.2		6	V
Ambient temperature	-40	25	85	°C

## ELECTRICAL CHARACTERISTICS

LC9018CXXTR263DC/N(2.63V)

(T<sub>OPT</sub> = 25°C, Unless otherwise specified.)

Symbol	Parameter	Conditions	Reference data			Unit
			Min.	Typ.	Max.	
-V <sub>DET</sub>	Detector threshold		2.577	2.63	2.683	V
I <sub>SS</sub>	Current consumption	VDD=4.63V		4.5	10	uA
V <sub>DDH</sub>	Maximum operating voltage				6	V
V <sub>DDL</sub>	Minimum operating voltage			0.5		V
I <sub>OUT</sub>	Output current	Pch VDS=-2.1V, VDD=4.5V	1.0	2.0		mA
T <sub>DET</sub>	Output delay time	VDD drop from V <sub>DET</sub> +100mV to V <sub>DET</sub> -100mV		8		uS

LC9018CXXTR293DC/N(2.93V)

(T<sub>OPT</sub> = 25°C, Unless otherwise specified.)

Symbol	Parameter	Conditions	Reference data			Unit
			Min.	Typ.	Max.	
-V <sub>DET</sub>	Detector threshold		2.871	2.93	2.989	V
I <sub>SS</sub>	Current consumption	VDD=4.93V		4.5	10	uA
V <sub>DDH</sub>	Maximum operating voltage				6	V
V <sub>DDL</sub>	Minimum operating voltage			0.5		V
I <sub>OUT</sub>	Output current	Pch VDS=-2.1V, VDD=4.5V	1.0	2.0		mA
T <sub>DET</sub>	Output delay time	VDD drop from V <sub>DET</sub> +100mV to V <sub>DET</sub> -100mV		8		uS

## ELECTRICAL CHARACTERISTICS BY OUTPUT DELAY TIME

Part Number	Test Condition	Output Delay Time			Unit
		Min.	Typ.	Max.	
LC9018CXXTRXXXDC/N	VDD=1.0V to Vdet+1.0V	140	200	300	ms

## BLOCK DIAGRAM

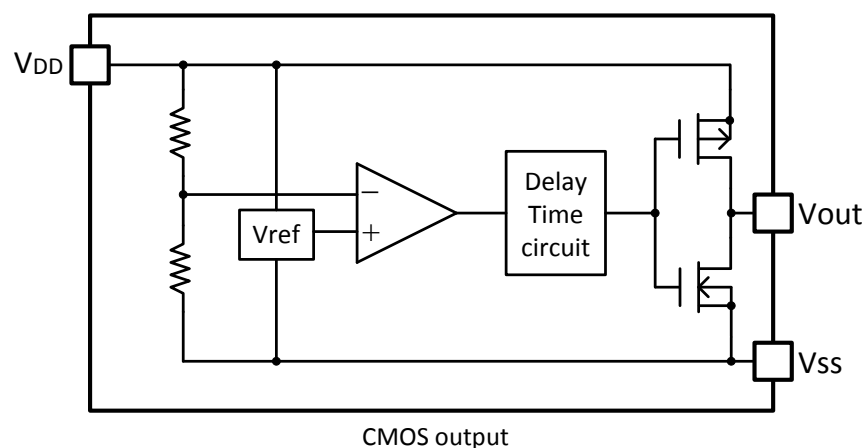
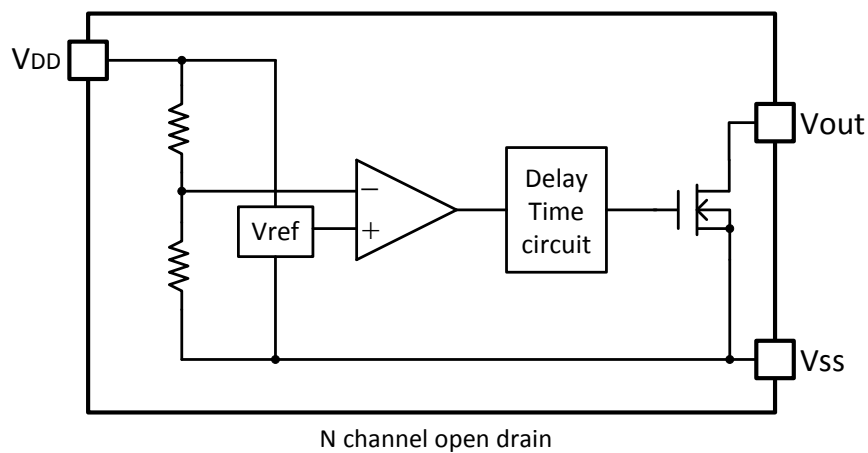

## FUNCTION DESCRIPTION

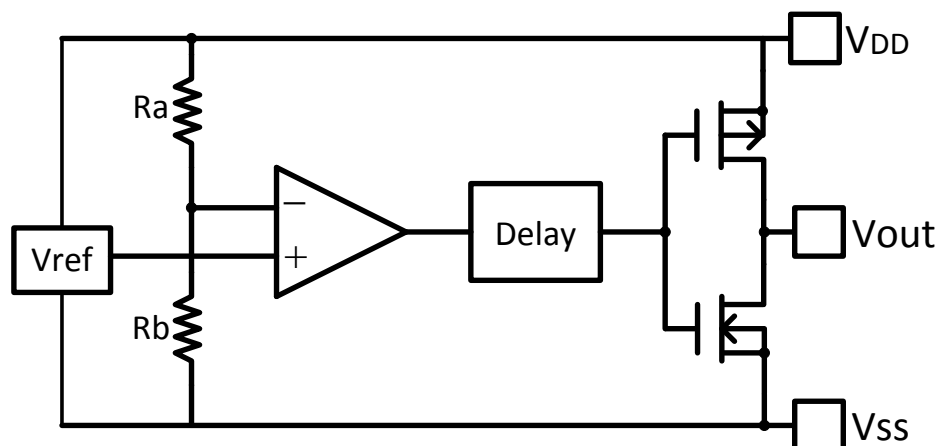

High precision low temperature co-efficiency reference voltage is applied to the negative input of a comparator. Input voltage, divided by resistor array of Ra and Rb, is applied to the positive input of the comparator. Output of the comparator passes a delay circuit and a series of buffer to drive the output CMOS pair.

$$V_{DET} = V_{REF} * (1 + R_a/R_b)$$

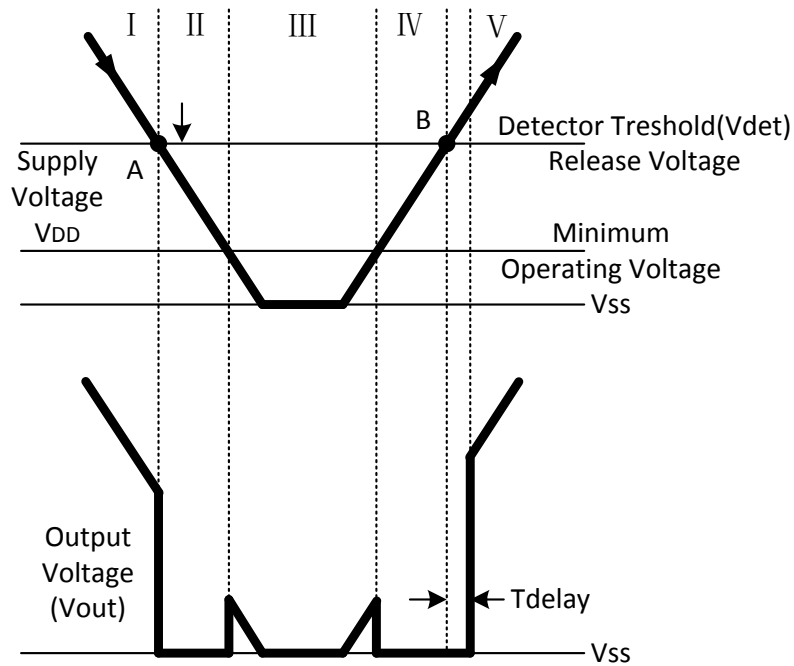

No.	Operation status	Output status
I	VDD > Vdet	Output voltage is equal to the supply voltage
II	VDD drops below Vdet	Output voltage equals to GND level
III	VDD drops further below VDDL	Output voltage is undefined
IV	VDD rises above VDDL	Output voltage equals to GND level
V	VDD rises above Vdet	Output voltage equals to supply voltage after Tdelay

## TEST CIRCUITS

(1) Supply current test circuit

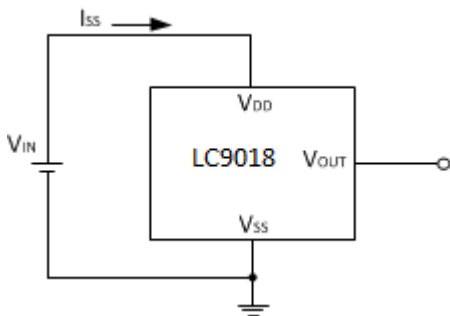

(2) Detector threshold test circuit

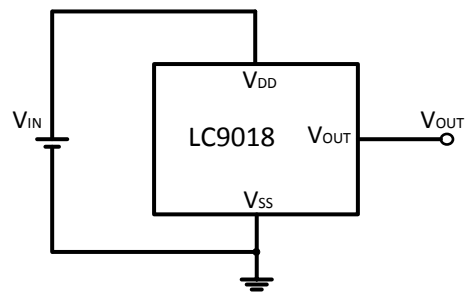

(3) NCH Drive Output Current Test Circuit

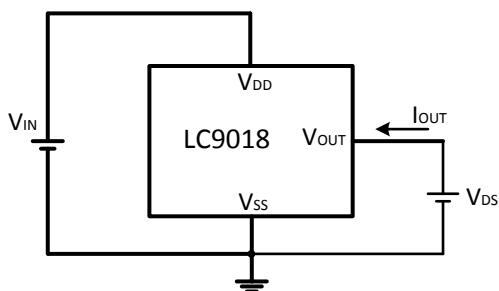

(4) PCH Drive Output Current Test Circuit

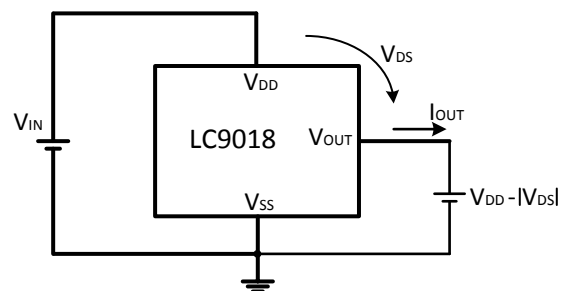

## TYPICAL PERFORMANCE CHARACTERISTICS

1) Supply current vs. Input voltage

Detector threshold=2.93V

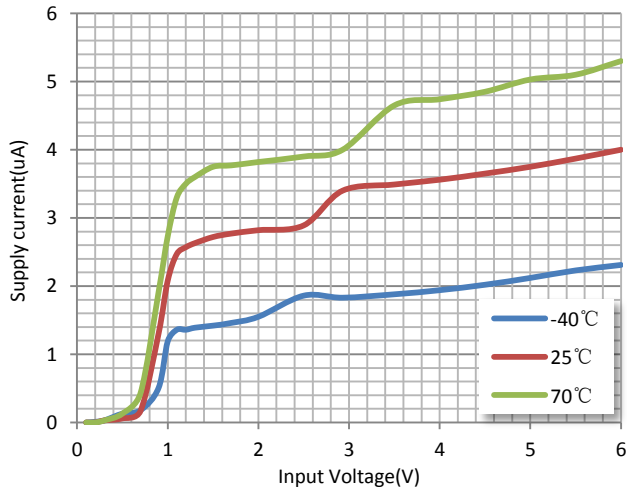

2) Detector Threshold vs. Temperature

Detector threshold=2.93V

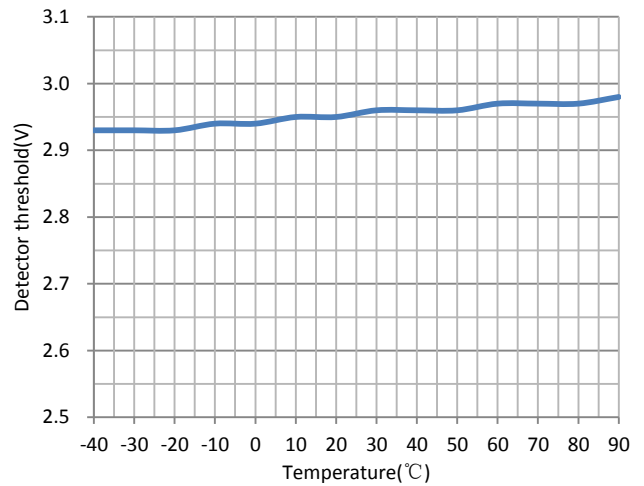

3) Nch Driver Output Current vs. VDS

Detector threshold=2.93V

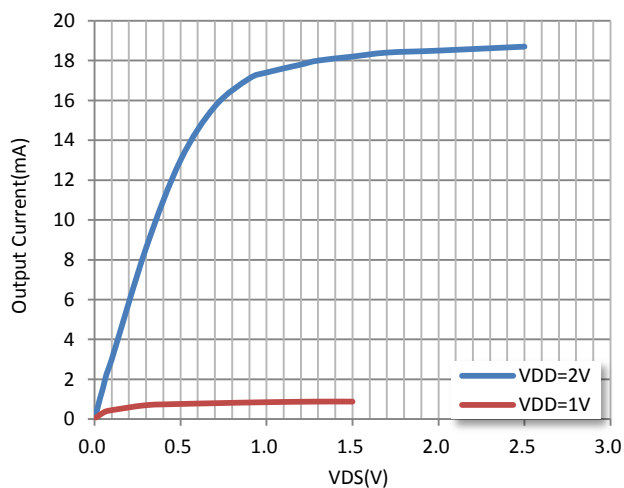

4) NCH Driver Output Current vs. Input Voltage

Detector threshold=2.93V

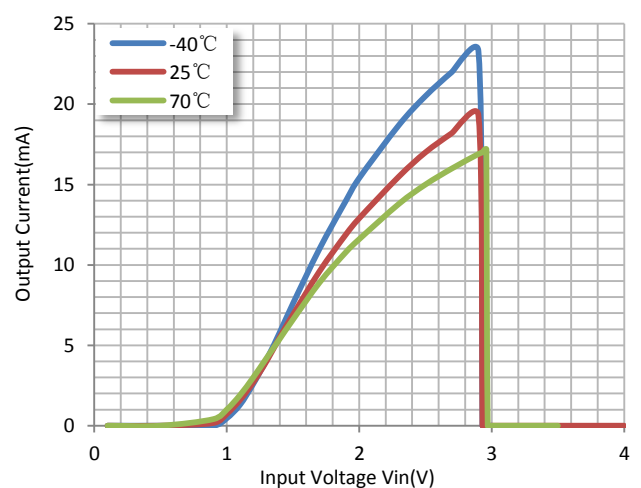

5) PCH Driver Output Current vs. Input Current

Detector threshold=2.93V

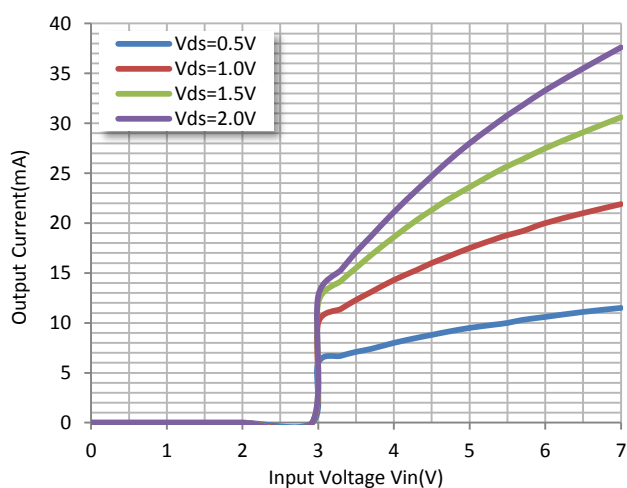

## PACKAGE LINE

Package	TSOT-23	Devices per reel	3000pcs						
Package dimension:									
<p>The drawing shows two views of the TSOT-23 package. The left view is a top-down perspective showing the package body with dimensions A (total height), B (width of the lead frame), C (total width), D (width of the package body), and E (width of the lead frame). The right view is a side profile showing the package body with dimensions F (width of the top lead), G (height of the top lead), H (width of the bottom lead), and K (width of the package body).</p>									
	<b>A</b>	<b>B</b>	<b>C</b>	<b>D</b>	<b>E</b>	<b>F</b>	<b>G</b>	<b>H</b>	<b>K</b>
出厂标准	2.4±0.15	0.95±0.05	2.9±0.1	1.3±0.1	0.40±0.1	0.15±0.08	0.4±0.1	0.07±0.07	1.00±0.05
Unit: mm									