

# LITIX™ Basic

TLD1120EL

1 Channel High-Side Current Source



<b>Package</b>	PG-SSOP-14
<b>Marking</b>	TLD1120

## 1 Overview

### Applications

- Exterior LED lighting applications such as tail/brake light, turn indicator, position light, side marker,...
- Interior LED lighting applications such as ambient lighting, interior illumination and dash board lighting.

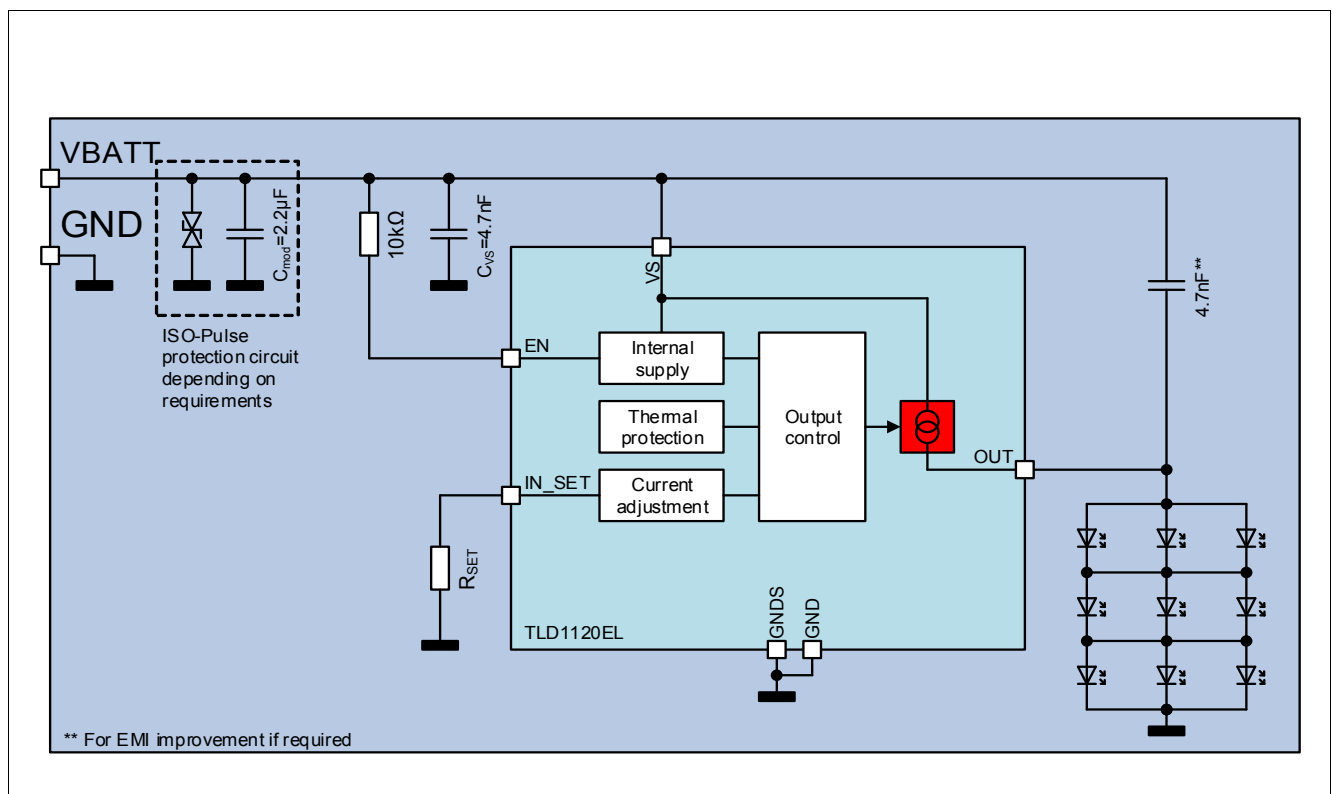

Application Diagram with TLD1120EL

## Overview

### Basic Features

- 1 Channel device with integrated output stage (current source), optimized to drive LEDs with output current up to 360 mA
- Low current consumption in sleep mode
- PWM-operation supported via VS- and EN-pin
- Output current adjustable via external low power resistor and possibility to connect PTC resistor for LED protection during over temperature conditions
- Reverse polarity protection and overload protection
- Undervoltage detection
- Wide temperature range:  $-40^{\circ}\text{C} < T_j < 150^{\circ}\text{C}$
- PG-SSOP-14 package with exposed heatslug

### Description

The LITIX™ Basic TLD1120EL is a one channel high side driver IC with integrated output stage. It is designed to control LEDs with a current up to 360 mA. In typical automotive applications the device is capable to drive i.e. 3 red LEDs with a current up to 180 mA, which is limited by thermal cooling aspects. The output current is controlled practically independent of load and supply voltage changes.

**Table 1 Product Summary**

Parameter	Symbol	Value
Operating voltage range	$V_{S(\text{nom})}$	5.5 V ... 40 V
Maximum voltage	$V_{S(\text{max})}$ $V_{\text{OUT}(\text{max})}$	40 V
Nominal output (load) current	$I_{\text{OUT}(\text{nom})}$	180 mA when using a supply voltage range of 8 V - 18 V (e.g. Automotive car battery). Currents up to $I_{\text{OUT}(\text{max})}$ possible in applications with low thermal resistance $R_{\text{thJA}}$
Maximum output (load) current	$I_{\text{OUT}(\text{max})}$	360 mA; depending on thermal resistance $R_{\text{thJA}}$
Output current accuracy at $R_{\text{SET}} = 12 \text{ k}\Omega$	$k_{\text{LT}}$	$2250 \pm 7\%$
Current consumption in sleep mode	$I_{S(\text{sleep,typ})}$	0.1 $\mu\text{A}$

### Protective Functions

- ESD protection
- Under voltage lock out
- Over Load protection
- Over Temperature protection
- Reverse Polarity protection

Block Diagram

## 2 Block Diagram

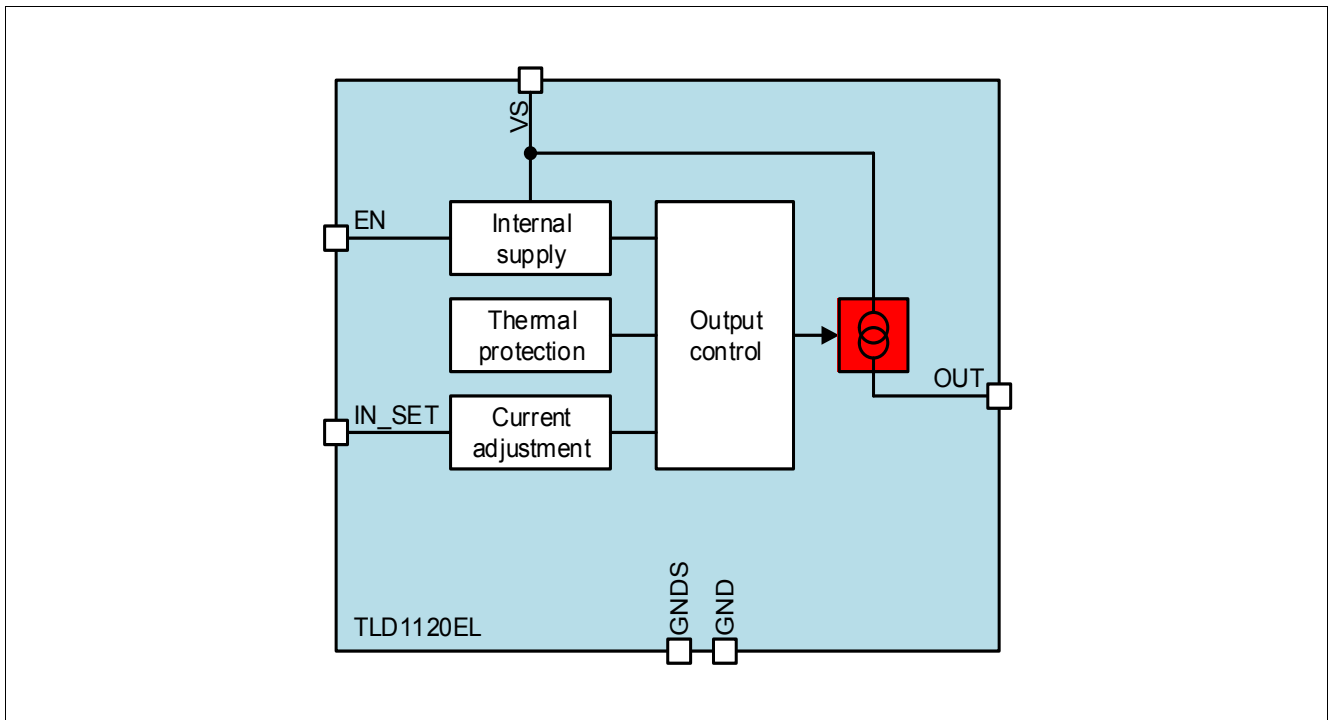

Figure 1 Basic Block Diagram

### 3 Pin Configuration

#### 3.1 Pin Assignment

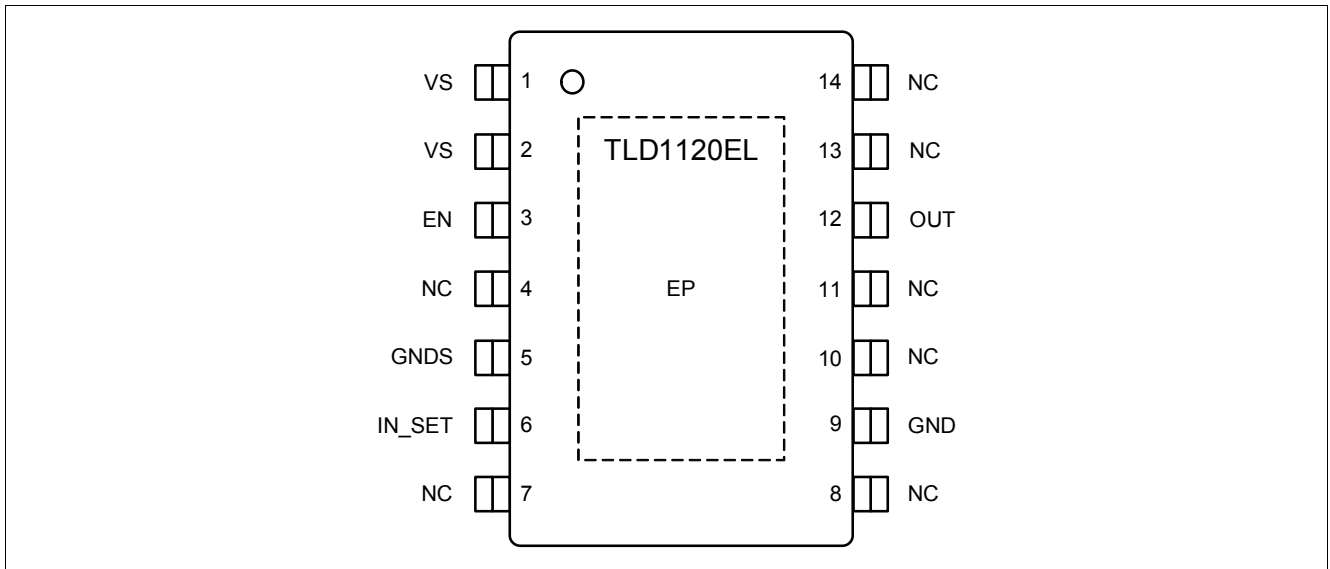

Figure 2 Pin Configuration

Pin Configuration

3.2 Pin Definitions and Functions

Pin	Symbol	Input/ Output	Function
1, 2	VS	–	<b>Supply Voltage;</b> battery supply, connect a decoupling capacitor (100 nF - 1 μF) to GND
3	EN	I	<b>Enable pin</b>
4	NC	–	<b>Pin not connected</b>
5	GNDS	–	<sup>1)</sup> <b>GNDS;</b> Signal GND, connect to GND
6	IN_SET	I/O	<b>Input / SET pin;</b> Connect a low power resistor to adjust the output current
7	NC	–	<b>Pin not connected</b>
8	NC	–	<b>Pin not connected</b>
9	GND	–	<sup>1)</sup> <b>Ground</b>
10	NC	–	<b>Pin not connected</b>
11	NC	–	<b>Pin not connected</b>
12	OUT	O	<b>Output</b>
13	NC	–	<b>Pin not connected</b>
14	NC	–	<b>Pin not connected</b>
Exposed Pad	GND	–	<sup>1)</sup> <b>Exposed Pad;</b> connect to GND in application

1) Connect all GND-pins together.

General Product Characteristics

## 4 General Product Characteristics

### 4.1 Absolute Maximum Ratings

#### Absolute Maximum Ratings <sup>1)</sup>

$T_j = -40^{\circ}\text{C}$  to  $+150^{\circ}\text{C}$ ; all voltages with respect to ground, positive current flowing into pin for input pins (I), positive currents flowing out of the I/O and output pins (O) (unless otherwise specified)

Pos.	Parameter	Symbol	Limit Values		Unit	Conditions
			Min.	Max.		
<b>Voltages</b>						
4.1.1	Supply voltage	$V_S$	-16	40	V	-
4.1.2	Input voltage EN	$V_{EN}$	-16	40	V	-
4.1.3	Input voltage EN related to $V_S$	$V_{EN(VS)}$	$V_S - 40$	$V_S + 16$	V	-
4.1.4	Input voltage EN related to $V_{OUT}$ $V_{EN} - V_{OUT}$	$V_{EN} - V_{OUT}$	-16	40	V	-
4.1.5	Output voltage	$V_{OUT}$	-1	40	V	-
4.1.6	Power stage voltage $V_{PS} = V_S - V_{OUT}$	$V_{PS}$	-16	40	V	-
4.1.7	IN_SET voltage	$V_{IN\_SET}$	-0.3	6	V	-
<b>Currents</b>						
4.1.8	IN_SET current	$I_{IN\_SET}$	-	2	mA	-
4.1.9	Output current	$I_{OUT}$	-	390	mA	-
<b>Temperatures</b>						
4.1.10	Junction temperature	$T_j$	-40	150	$^{\circ}\text{C}$	-
4.1.11	Storage temperature	$T_{stg}$	-55	150	$^{\circ}\text{C}$	-
<b>ESD Susceptibility</b>						
4.1.12	ESD resistivity to GND	$V_{ESD}$	-2	2	kV	Human Body Model (100 pF via 1.5 k $\Omega$ ) <sup>2)</sup>
4.1.13	ESD resistivity all pins to GND	$V_{ESD}$	-500	500	V	CDM <sup>3)</sup>
4.1.14	ESD resistivity corner pins to GND	$V_{ESD}$	-750	750	V	CDM <sup>3)</sup>

1) Not subject to production test, specified by design

2) ESD susceptibility, Human Body Model "HBM" according to ANSI/ESDA/JEDEC JS-001-2011

3) ESD susceptibility, Charged Device Model "CDM" according to JESD22-C101E

*Note: Stresses above the ones listed here may cause permanent damage to the device. Exposure to absolute maximum rating conditions for extended periods may affect device reliability.*

*Note: Integrated protection functions are designed to prevent IC destruction under fault conditions described in the data sheet. Fault conditions are considered as "outside" normal operating range. Protection functions are not designed for continuous repetitive operation.*

General Product Characteristics

4.2 Functional Range

Pos.	Parameter	Symbol	Limit Values		Unit	Conditions
			Min.	Max.		
4.2.15	Supply voltage range for normal operation	$V_{S(nom)}$	5.5	40	V	–
4.2.16	Power on reset threshold	$V_{S(POR)}$	–	5	V	$V_{EN} = V_S$ $R_{SET} = 12\text{ k}\Omega$ $I_{OUT} = 80\% I_{OUT(nom)}$ $V_{OUT} = 2.5\text{ V}$
4.2.17	Junction temperature	$T_j$	-40	150	°C	–

Note: Within the functional range the IC operates as described in the circuit description. The electrical characteristics are specified within the conditions given in the related electrical characteristics table.

4.3 Thermal Resistance

Pos.	Parameter	Symbol	Limit Values			Unit	Conditions
			Min.	Typ.	Max.		
4.3.1	Junction to Case	$R_{thJC}$	–	8	10	K/W	<sup>1) 2)</sup>
4.3.2	Junction to Ambient 1s0p board	$R_{thJA1}$	–	61	–	K/W	<sup>1) 3)</sup> $T_a = 85\text{ °C}$ $T_a = 135\text{ °C}$
4.3.3	Junction to Ambient 2s2p board	$R_{thJA2}$	–	45	–	K/W	<sup>1) 4)</sup> $T_a = 85\text{ °C}$ $T_a = 135\text{ °C}$

- 1) Not subject to production test, specified by design. Based on simulation results.
- 2) Specified  $R_{thJC}$  value is simulated at natural convection on a cold plate setup (all pins and the exposed Pad are fixed to ambient temperature).  $T_a = 85\text{ °C}$ , Total power dissipation 1.5 W.
- 3) The  $R_{thJA}$  values are according to Jedec JESD51-3 at natural convection on 1s0p FR4 board. The product (chip + package) was simulated on a 76.2 x 114.3 x 1.5 mm<sup>3</sup> board with 70 μm Cu, 300 mm<sup>2</sup> cooling area. Total power dissipation 1.5 W distributed statically and homogeneously over power stage.
- 4) The  $R_{thJA}$  values are according to Jedec JESD51-5,-7 at natural convection on 2s2p FR4 board. The product (chip + package) was simulated on a 76.2 x 114.3 x 1.5 mm<sup>3</sup> board with 2 inner copper layers (outside 2 x 70 μm Cu, inner 2 x 35 μm Cu). Where applicable, a thermal via array under the exposed pad contacted the first inner copper layer. Total power dissipation 1.5 W distributed statically and homogeneously over power stage.

EN Pin

## 5 EN Pin

The EN pin is a dual function pin:



**Figure 3** Block Diagram EN pin

Note: The current consumption at the EN-pin  $I_{EN}$  needs to be added to the total device current consumption. The total current consumption is the sum of the currents at the VS-pin  $I_S$  and the EN-pin  $I_{EN}$ .

### 5.1 EN Function

If the voltage at the pin EN is below a threshold of  $V_{EN(off)}$  the LITIX™ Basic IC will enter Sleep mode. In this state all internal functions are switched off, the current consumption is reduced to  $I_{S(sleep)}$ . A voltage above  $V_{EN(on)}$  at this pin enables the device after the Power on reset time  $t_{POR}$ .



**Figure 4** Power on reset



EN Pin

### 5.2 Internal Supply Pin

The EN pin can be used to supply the internal logic. There are two typical application conditions, where this feature can be used:

- 1) In “DC/DC control Buck” configurations, where the voltage  $V_S$  can be below 5.5V.
- 2) In configurations, where a PWM signal is applied at the Vbatt pin of a light module. The buffer capacitor  $C_{BUF}$  is used to supply the LITIX™ Basic IC during Vbatt low ( $V_S$  low) periods. This feature can be used to minimize the turn-on time to the values specified in **Pos. 7.2.11**. Otherwise, the power-on reset delay time  $t_{POR}$  (**Pos. 5.4.4**) has to be considered.

The capacitor can be calculated using the following formula:

$$C_{BUF} = t_{LOW(max)} \cdot \frac{I_{EN(LS)}}{V_S - V_{D1} - V_{S(POR)}} \quad (1)$$

See also a typical application drawing in **Chapter 8**.

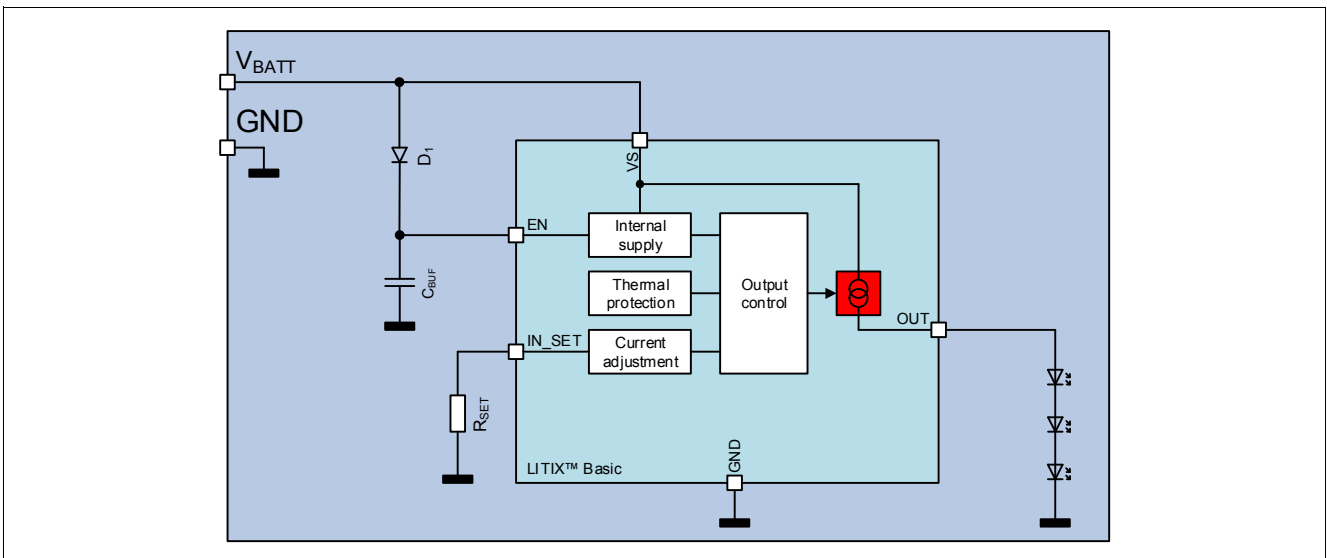

Figure 5 External circuit when applying a fast PWM signal on V<sub>BATT</sub>

EN Pin



**Figure 6** Typical waveforms when applying a fast PWM signal on  $V_{BATT}$

The parameter  $t_{ON(VS)}$  is defined at [Pos. 7.2.11](#). The parameter  $t_{OFF(VS)}$  depends on the load and supply voltage  $V_{BATT}$  characteristics.

### 5.3 EN Unused

In case of an unused EN pin, there are two different ways to connect it:

#### 5.3.1 EN - Pull Up to VS

The EN pin can be connected with a pull up resistor (e.g. 10 k $\Omega$ ) to  $V_S$  potential. In this configuration the LITIX™ Basic IC is always enabled.

#### 5.3.2 EN - Direct Connection to VS

The EN pin can be connected directly to the VS pin (IC always enabled). This configuration has the advantage (compared to the configuration described in [Chapter 5.3.1](#)) that no additional external component is required.

## 5.4 Electrical Characteristics Internal Supply / EN Pin

### Electrical Characteristics Internal Supply / EN pin

Unless otherwise specified,  $V_S = 5.5\text{ V to }40\text{ V}$ ,  $T_j = -40^\circ\text{C to }+150^\circ\text{C}$ ,  $R_{SET} = 12\text{ k}\Omega$  all voltages with respect to ground, positive current flowing into pin for input pins (I), positive currents flowing out of the I/O and output pins (O) (unless otherwise specified)

Pos.	Parameter	Symbol	Limit Values			Unit	Conditions
			Min.	Typ.	Max.		
5.4.1	Current consumption, sleep mode	$I_{S(\text{sleep})}$	-	0.1	2	$\mu\text{A}$	<sup>1)</sup> $V_{EN} = 0.5\text{ V}$ $T_j < 85^\circ\text{C}$ $V_S = 18\text{ V}$ $V_{OUT} = 3.6\text{ V}$
5.4.2	Current consumption, active mode	$I_{S(\text{on})}$	-	-	-	$\text{mA}$	<sup>2)</sup> $I_{IN\_SET} = 0\text{ }\mu\text{A}$ $T_j < 105^\circ\text{C}$ $V_S = 18\text{ V}$ $V_{OUT} = 3.6\text{ V}$ $V_{EN} = 5.5\text{ V}$ $V_{EN} = 18\text{ V}$ <sup>1)</sup> $R_{EN} = 10\text{ k}\Omega$ between VS and EN-pin
5.4.3	Current consumption, device disabled via IN_SET	$I_{S(\text{dis,IN\_SET})}$	-	-	-	$\text{mA}$	<sup>2)</sup> $V_S = 18\text{ V}$ $T_j < 105^\circ\text{C}$ $V_{IN\_SET} = 5\text{ V}$ $V_{EN} = 5.5\text{ V}$ $V_{EN} = 18\text{ V}$ <sup>1)</sup> $R_{EN} = 10\text{ k}\Omega$ between VS and EN-pin
5.4.4	Power-on reset delay time <sup>3)</sup>	$t_{POR}$	-	-	25	$\mu\text{s}$	<sup>1)</sup> $V_S = V_{EN} = 0 \rightarrow 13.5\text{ V}$ $V_{OUT(\text{nom})} = 3.6 \pm 0.3\text{ V}$ $I_{OUT} = 80\% I_{OUT(\text{nom})}$
5.4.5	Required supply voltage for output activation	$V_{S(\text{on})}$	-	-	4	$\text{V}$	$V_{EN} = 5.5\text{ V}$ $V_{OUT} = 3\text{ V}$ $I_{OUT} = 50\% I_{OUT(\text{nom})}$
5.4.6	Required supply voltage for current control	$V_{S(\text{CC})}$	-	-	5.2	$\text{V}$	$V_{EN} = 5.5\text{ V}$ $V_{OUT} = 3.6\text{ V}$ $I_{OUT} \geq 90\% I_{OUT(\text{nom})}$
5.4.7	EN turn on threshold	$V_{EN(\text{on})}$	-	-	2.5	$\text{V}$	-
5.4.8	EN turn off threshold	$V_{EN(\text{off})}$	0.8	-	-	$\text{V}$	-
5.4.9	EN input current during low supply voltage	$I_{EN(\text{LS})}$	-	-	1.8	$\text{mA}$	<sup>1)</sup> $V_S = 4.5\text{ V}$ $T_j < 105^\circ\text{C}$ $V_{EN} = 5.5\text{ V}$
5.4.10	EN high input current	$I_{EN(\text{H})}$	-	-	-	$\text{mA}$	$T_j < 105^\circ\text{C}$ $V_S = 13.5\text{ V}, V_{EN} = 5.5\text{ V}$ $V_S = 18\text{ V}, V_{EN} = 5.5\text{ V}$ $V_S = V_{EN} = 18\text{ V}$ <sup>1)</sup> $V_S = 18\text{ V}, R_{EN} = 10\text{ k}\Omega$ between VS and EN-pin

1) Not subject to production test, specified by design

---

**EN Pin**

- 2) The total device current consumption is the sum of the currents  $I_S$  and  $I_{EN(H)}$ , please refer to **Pos. 5.4.10**
- 3) See also **Figure 4**

IN\_SET Pin

## 6 IN\_SET Pin

The IN\_SET pin is a multiple function pin for output current definition and input:

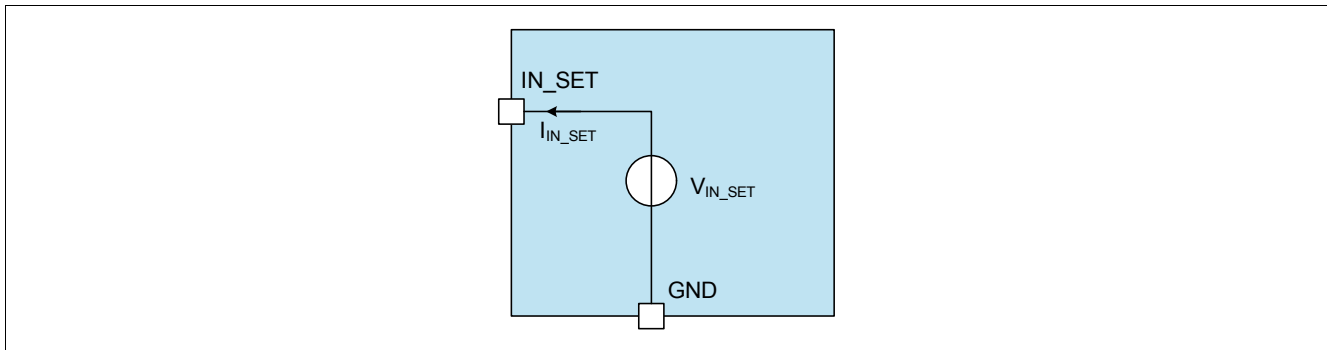

Figure 7 Block Diagram IN\_SET pin

### 6.1 Output Current Adjustment via RSET

The current adjustment can be done by placing a low power resistor ( $R_{SET}$ ) at the IN\_SET pin to ground. The dimensioning of the resistor can be done using the formula below:

$$R_{SET} = \frac{k}{I_{OUT}} \quad (2)$$

The gain factor  $k$  ( $R_{SET}$  \* output current) is specified in [Pos. 7.2.4](#) and [Pos. 7.2.5](#). The current through the  $R_{SET}$  is defined by the resistor itself and the reference voltage  $V_{IN\_SET(ref)}$ , which is applied to the IN\_SET during supplied device.

### 6.2 Input Pin

The IN\_SET pin can be connected via  $R_{SET}$  to the open-drain output of a  $\mu C$  or to an external NMOS transistor as described in [Figure 8](#). This signal can be used to turn off the output stage of the IC. A minimum IN\_SET current of  $I_{IN\_SET(act)}$  is required to turn on the output stage. This feature is implemented to prevent glimming of LEDs caused by leakage currents on the IN\_SET pin, see [Figure 10](#) for details.

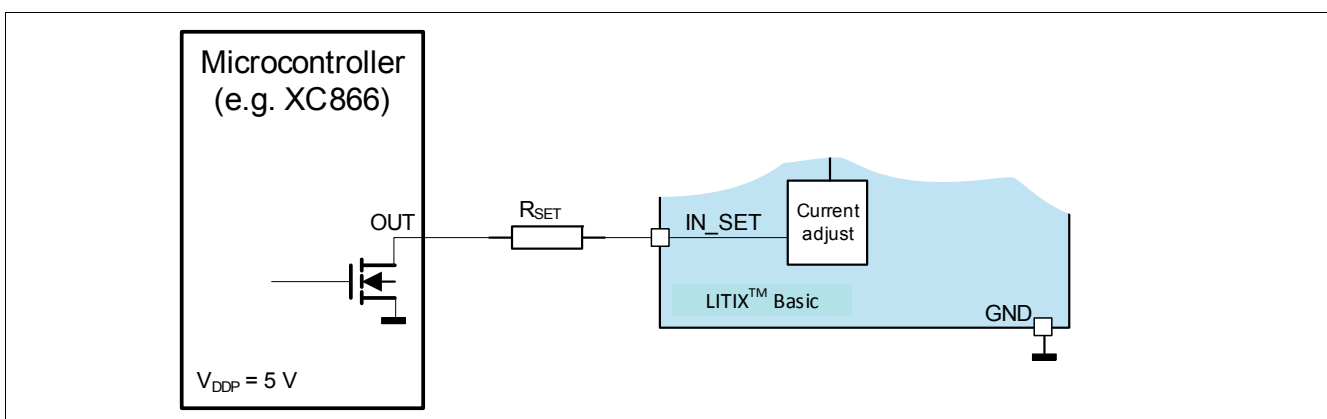

Figure 8 Schematics IN\_SET interface to  $\mu C$

The resulting switching times are shown in [Figure 9](#):

IN\_SET Pin

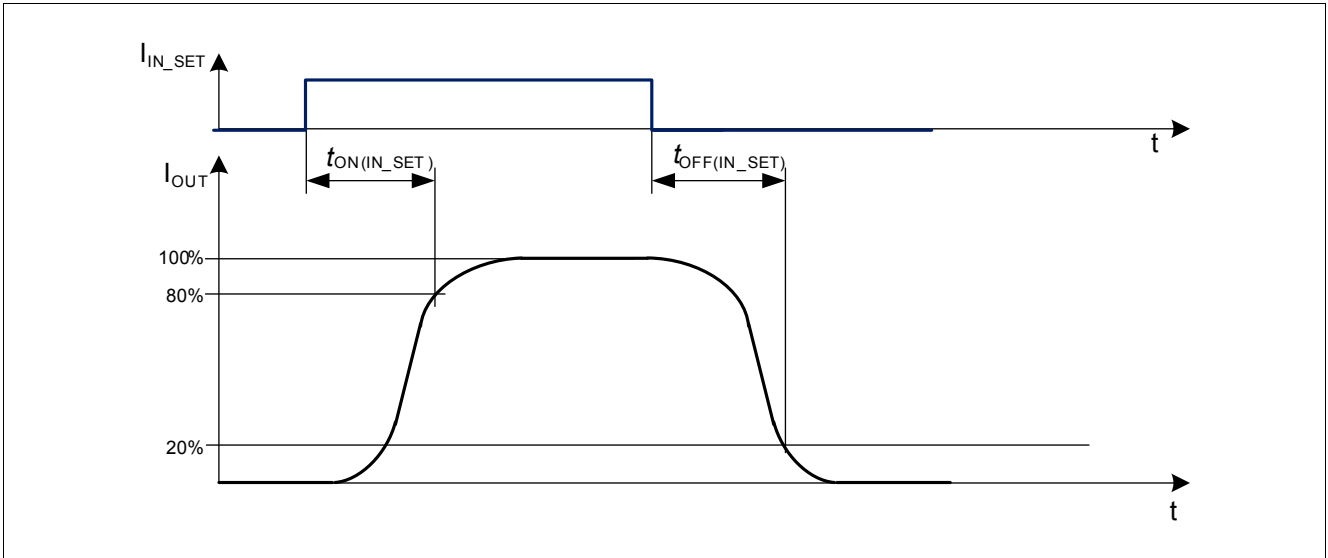

Figure 9 Switching times via IN\_SET

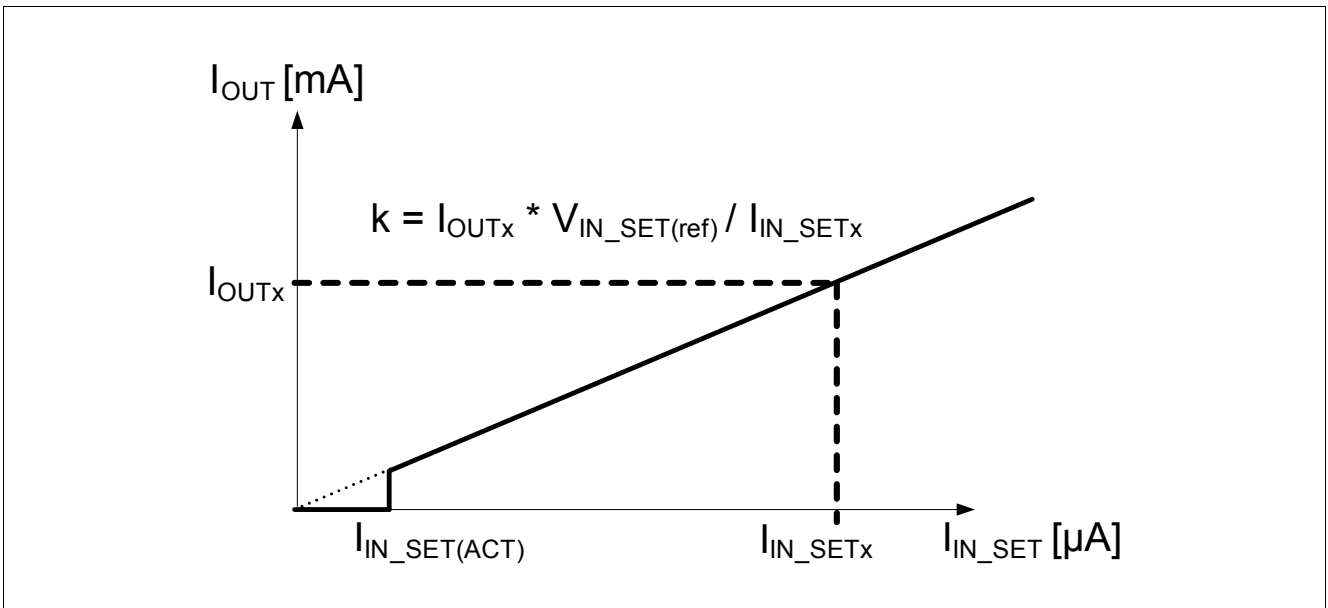

Figure 10  $I_{OUT}$  versus  $I_{INSET}$

IN\_SET Pin

### 6.3 Electrical Characteristics IN\_SET Pin

#### Electrical Characteristics IN\_SET pin

Unless otherwise specified,  $V_S = 5.5\text{ V to }40\text{ V}$ ,  $T_j = -40^\circ\text{C to }+150^\circ\text{C}$ ,  $R_{SET} = 12\text{ k}\Omega$ , all voltages with respect to ground, positive current flowing into pin for input pins (I), positive currents flowing out of the I/O and output pins (O) (unless otherwise specified)

Pos.	Parameter	Symbol	Limit Values			Unit	Conditions
			Min.	Typ.	Max.		
6.3.1	IN_SET reference voltage	$V_{IN\_SET(ref)}$	1.19	1.23	1.27	V	<sup>1)</sup> $V_{OUT} = 3.6\text{ V}$ $T_j = 25\dots115\text{ }^\circ\text{C}$
6.3.2	IN_SET activation current without turn on of output stage	$I_{IN\_SET(act)}$	2	–	15	$\mu\text{A}$	See <a href="#">Figure 10</a>

1) Not subject to production test, specified by design

Power Stage

## 7 Power Stage

The output stage is realized as high side current source with a current of 360 mA. During off state the leakage current at the output stage is minimized in order to prevent a slightly glowing LED.

The maximum current of the channel is limited by the power dissipation and used PCB cooling areas (which results in the applications  $R_{thJA}$ ).

For an operating current control loop the supply and output voltages according to the following parameters have to be considered:

- Required supply voltage for current control  $V_{S(CC)}$ , **Pos. 5.4.6**
- Voltage drop over output stage during current control  $V_{PS(CC)}$ , **Pos. 7.2.6**
- Required output voltage for current control  $V_{OUT(CC)}$ , **Pos. 7.2.7**

### 7.1 Protection

The device provides embedded protective functions, which are designed to prevent IC destruction under fault conditions described in this data sheet. Fault conditions are considered as “outside” normal operating range. Protective functions are neither designed for continuous nor for repetitive operation.

#### 7.1.1 Over Load Behavior

An over load detection circuit is integrated in the LITIX™ Basic IC. It is realized by a temperature monitoring of the output stage (OUT).

As soon as the junction temperature exceeds the current reduction temperature threshold  $T_{j(CRT)}$  the output current will be reduced by the device by reducing the  $IN\_SET$  reference voltage  $V_{IN\_SET(ref)}$ . This feature avoids LED’s flickering during static output overload conditions. Furthermore, it protects LEDs against over temperature, which are mounted thermally close to the device. If the device temperature still increases, the output current decreases close to 0 A. As soon as the device cools down the output current rises again.

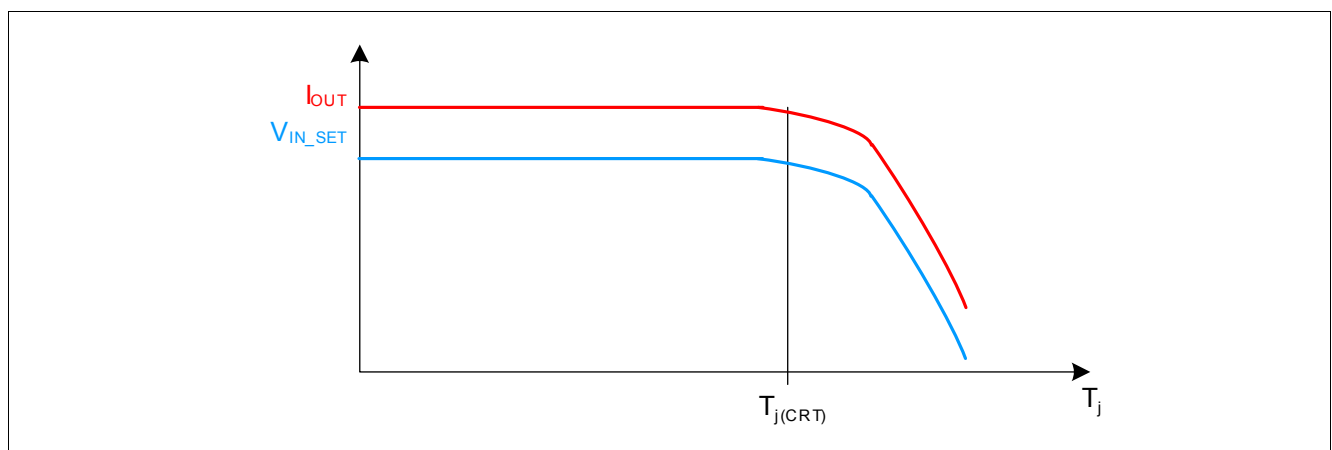

**Figure 11 Output current reduction at high temperature**

*Note: This high temperature output current reduction is realized by reducing the  $IN\_SET$  reference voltage (Pos. 6.3.1). In case of very high power loss applied to the device and very high junction temperature the output current may drop down to  $I_{OUT} = 0$  mA, after a slight cooling down the current increases again.*

#### 7.1.2 Reverse Battery Protection

The TLD1120EL has an integrated reverse battery protection feature. This feature protects the driver IC itself, but also connected LEDs. The output reverse current is limited to  $I_{OUTx(rev)}$  by the reverse battery protection.



## Power Stage

Note: Due to the reverse battery protection a reverse protection diode for the light module may be obsolete. In case of high ISO-pulse requirements and only minor protecting components like capacitors a reverse protection diode may be reasonable. The external protection circuit needs to be verified in the application.

## 7.2 Electrical Characteristics Power Stage

### Electrical Characteristics Power Stage

Unless otherwise specified:  $V_S = 5.5\text{ V to }18\text{ V}$ ,  $T_j = -40^\circ\text{C to }+150^\circ\text{C}$ ,  $V_{OUT} = 3.6\text{ V}$ , all voltages with respect to ground, positive current flowing into pin for input pins (I), positive currents flowing out of the I/O and output pins (O) (unless otherwise specified)

Pos.	Parameter	Symbol	Limit Values			Unit	Conditions
			Min.	Typ.	Max.		
7.2.1	Output leakage current	$I_{OUT(leak)}$	-	-	21 9	$\mu\text{A}$	$V_{EN} = 5.5\text{ V}$ $I_{IN\_SET} = 0\ \mu\text{A}$ $V_{OUT} = 2.5\text{ V}$ $T_j = 150^\circ\text{C}$ 1) $T_j = 85^\circ\text{C}$
7.2.2	Output leakage current in boost over battery setup	$-I_{OUT(leak,B2B)}$	-	-	150	$\mu\text{A}$	1) $V_{EN} = 5.5\text{ V}$ $I_{IN\_SET} = 0\ \mu\text{A}$ $V_{OUT} = V_S = 40\text{ V}$
7.2.3	Reverse output current	$-I_{OUT(rev)}$	-	-	3	$\mu\text{A}$	1) $V_S = -16\text{ V}$ Output load: LED with break down voltage < $-0.6\text{ V}$
7.2.4	Output current accuracy limited temperature range	$k_{LT}$	2092 1935	2250 2250	2408 2565		1) $T_j = 25\dots115^\circ\text{C}$ $V_S = 8\dots18\text{ V}$ $V_{PS} = 2\text{ V}$ $R_{SET} = 6\dots12\text{ k}\Omega$ $R_{SET} = 30\text{ k}\Omega$
7.2.5	Output current accuracy over temperature	$k_{ALL}$	2092 1935	2250 2250	2408 2565		1) $T_j = -40\dots115^\circ\text{C}$ $V_S = 8\dots18\text{ V}$ $V_{PS} = 2\text{ V}$ $R_{SET} = 6\dots12\text{ k}\Omega$ $R_{SET} = 30\text{ k}\Omega$
7.2.6	Voltage drop over power stage during current control $V_{PS(CC)} = V_S - V_{OUT}$	$V_{PS(CC)}$	0.75	-	-	V	1) $V_S = 13.5\text{ V}$ $R_{SET} = 12\text{ k}\Omega$ $I_{OUT} \geq 90\%$ of $(k_{LT(typ)}/R_{SET})$
7.2.7	Required output voltage for current control	$V_{OUT(CC)}$	2.3	-	-	V	1) $V_S = 13.5\text{ V}$ $R_{SET} = 12\text{ k}\Omega$ $I_{OUT} \geq 90\%$ of $(k_{LT(typ)}/R_{SET})$
7.2.8	Maximum output current	$I_{OUT(max)}$	360	-	-	mA	$R_{SET} = 4.7\text{ k}\Omega$ The maximum output current is limited by the thermal conditions. Please refer to <b>Pos. 4.3.1 - Pos. 4.3.3</b>
7.2.9	IN_SET turn on time	$t_{ON(IN\_SET)}$	-	-	15	$\mu\text{s}$	$V_S = 13.5\text{ V}$ $I_{IN\_SET} = 0 \rightarrow 100\ \mu\text{A}$ $I_{OUT} = 80\%$ of $(k_{LT(typ)}/R_{SET})$

Power Stage

Electrical Characteristics Power Stage (cont'd)

Unless otherwise specified:  $V_S = 5.5\text{ V}$  to  $18\text{ V}$ ,  $T_j = -40^\circ\text{C}$  to  $+150^\circ\text{C}$ ,  $V_{OUT} = 3.6\text{ V}$ , all voltages with respect to ground, positive current flowing into pin for input pins (I), positive currents flowing out of the I/O and output pins (O) (unless otherwise specified)

Pos.	Parameter	Symbol	Limit Values			Unit	Conditions
			Min.	Typ.	Max.		
7.2.10	IN_SET turn off time	$t_{OFF(IN\_SET)}$	–	–	10	$\mu\text{s}$	$V_S = 13.5\text{ V}$ $I_{IN\_SET} = 100 \rightarrow 0\ \mu\text{A}$ $I_{OUT} = 20\%$ of $(k_{LT(typ)}/R_{SET})$
7.2.11	VS turn on time	$t_{ON(VS)}$	–	–	20	$\mu\text{s}$	<sup>1) 2)</sup> $V_{EN} = 5.5\text{ V}$ $R_{SET} = 12\text{ k}\Omega$ $V_S = 0 \rightarrow 13.5\text{ V}$ $I_{OUT} = 80\%$ of $(k_{LT(typ)}/R_{SET})$
7.2.12	Current reduction temperature threshold	$T_{j(CRT)}$	–	140	–	$^\circ\text{C}$	<sup>1)</sup> $I_{OUT} = 95\%$ of $(k_{LT(typ)}/R_{SET})$
7.2.13	Output current during current reduction at high temperature	$I_{OUT(CRT)}$	85% of $(k_{LT(typ)}/R_{SET})$	–	–	A	<sup>1)</sup> $R_{SET} = 12\text{ k}\Omega$ $T_j = 150\text{ }^\circ\text{C}$

- 1) Not subject to production test, specified by design
- 2) see also [Figure 6](#)

Application Information

8 Application Information

Note: The following information is given as a hint for the implementation of the device only and shall not be regarded as a description or warranty of a certain functionality, condition or quality of the device.

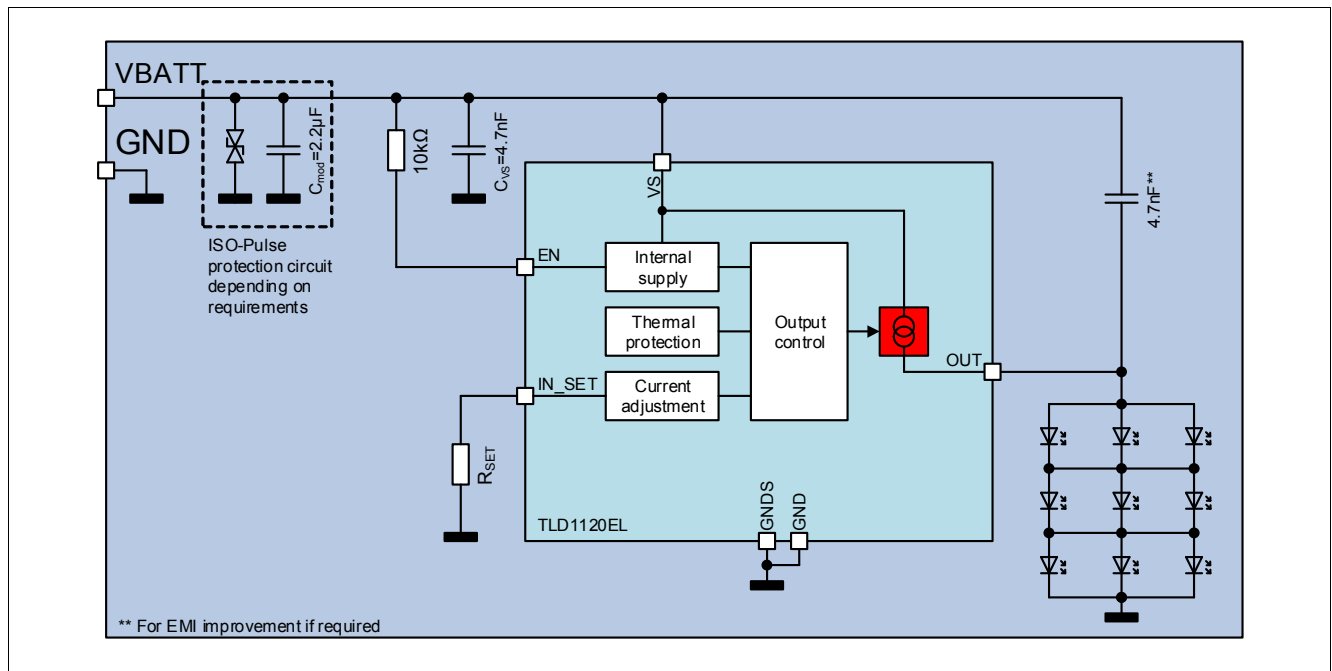

Figure 12 Application Diagram

Note: This is a very simplified example of an application circuit. In case of high ISO-pulse requirements a reverse protection diode may be used for LED protection. The function must be verified in the real application.

8.1 Further Application Information

- For further information you may contact <http://www.infineon.com/>

## 9 Package Outlines

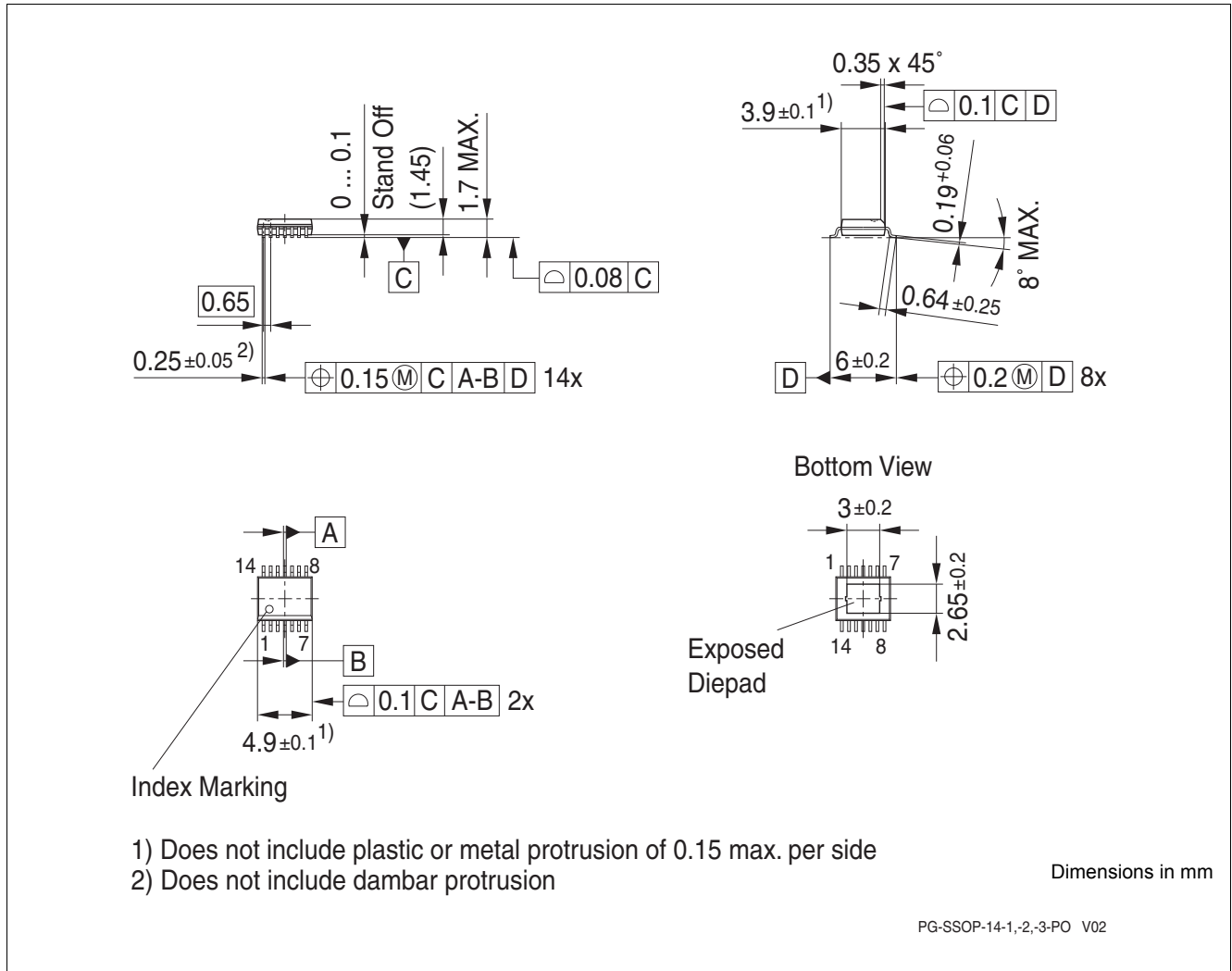

Figure 13 PG-SSOP-14

### Green Product (RoHS compliant)

To meet the world-wide customer requirements for environmentally friendly products and to be compliant with government regulations the device is available as a green product. Green products are RoHS-Compliant (i.e Pb-free finish on leads and suitable for Pb-free soldering according to IPC/JEDEC J-STD-020).

For further information on alternative packages, please visit our website:  
<http://www.infineon.com/packages>.

Revision History

## 10 Revision History

Revision	Date	Changes
1.0	2013-08-08	Initial revision of data sheet
1.1	2015-03-19	Updated parameters $K_{LT}$ and $K_{ALL}$ in the chapter Power Stage
1.2	2018-04-26	Updated to latest template
1.2	2018-04-26	Updated application drawing
1.2	2018-04-26	Updated package marking
1.2	2018-04-26	Updated package figure

## Table of Contents

<b>1</b>	<b>Overview</b> .....	<b>1</b>
<b>2</b>	<b>Block Diagram</b> .....	<b>3</b>
<b>3</b>	<b>Pin Configuration</b> .....	<b>4</b>
3.1	Pin Assignment .....	4
3.2	Pin Definitions and Functions .....	5
<b>4</b>	<b>General Product Characteristics</b> .....	<b>6</b>
4.1	Absolute Maximum Ratings .....	6
4.2	Functional Range .....	7
4.3	Thermal Resistance .....	7
<b>5</b>	<b>EN Pin</b> .....	<b>8</b>
5.1	EN Function .....	8
5.2	Internal Supply Pin .....	9
5.3	EN Unused .....	10
5.3.1	EN - Pull Up to VS .....	10
5.3.2	EN - Direct Connection to VS .....	10
5.4	Electrical Characteristics Internal Supply / EN Pin .....	11
<b>6</b>	<b>IN_SET Pin</b> .....	<b>13</b>
6.1	Output Current Adjustment via RSET .....	13
6.2	Input Pin .....	13
6.3	Electrical Characteristics IN_SET Pin .....	15
<b>7</b>	<b>Power Stage</b> .....	<b>16</b>
7.1	Protection .....	16
7.1.1	Over Load Behavior .....	16
7.1.2	Reverse Battery Protection .....	16
7.2	Electrical Characteristics Power Stage .....	17
<b>8</b>	<b>Application Information</b> .....	<b>19</b>
8.1	Further Application Information .....	19
<b>9</b>	<b>Package Outlines</b> .....	<b>20</b>
<b>10</b>	<b>Revision History</b> .....	<b>21</b>
	<b>Table of Contents</b> .....	<b>22</b>

## Trademarks

All referenced product or service names and trademarks are the property of their respective owners.

**Edition 2018-04-26**

**Published by**

**Infineon Technologies AG**

**81726 Munich, Germany**

**© 2018 Infineon Technologies AG.**

**All Rights Reserved.**

**Do you have a question about any aspect of this document?**

**Email: [erratum@infineon.com](mailto:erratum@infineon.com)**

**Document reference  
TLD1120EL**

## IMPORTANT NOTICE

The information given in this document shall in no event be regarded as a guarantee of conditions or characteristics ("Beschaffenhheitsgarantie").

With respect to any examples, hints or any typical values stated herein and/or any information regarding the application of the product, Infineon Technologies hereby disclaims any and all warranties and liabilities of any kind, including without limitation warranties of non-infringement of intellectual property rights of any third party.

In addition, any information given in this document is subject to customer's compliance with its obligations stated in this document and any applicable legal requirements, norms and standards concerning customer's products and any use of the product of Infineon Technologies in customer's applications.

The data contained in this document is exclusively intended for technically trained staff. It is the responsibility of customer's technical departments to evaluate the suitability of the product for the intended application and the completeness of the product information given in this document with respect to such application.

For further information on technology, delivery terms and conditions and prices, please contact the nearest Infineon Technologies Office ([www.infineon.com](http://www.infineon.com)).

## WARNINGS

Due to technical requirements products may contain dangerous substances. For information on the types in question please contact your nearest Infineon Technologies office.

Except as otherwise explicitly approved by Infineon Technologies in a written document signed by authorized representatives of Infineon Technologies, Infineon Technologies' products may not be used in any applications where a failure of the product or any consequences of the use thereof can reasonably be expected to result in personal injury.