



## Dynamic Differential Hall Effect Sensor

TLE4926C-HT E6547

### Data Sheet Version 1.1

#### Features

- High sensitivity
- Single chip solution
- Symmetrical thresholds
- High resistance to Piezo effects
- South and north pole pre-induction possible
- Low cut-off frequency
- Digital output signal
- Advanced performance by dynamic self calibration principle
- Two-wire and three-wire configuration possible
- Wide operating temperature range
- Fast start-up time
- Large operating air-gaps
- Reverse voltage protection at Vs- PIN
- Short- circuit and over temperature protection of output
- Digital output signal (voltage interface)
- Module style package with two integrated capacitors:
  - 4.7nF between Q and GND
  - 47nF<sup>1</sup> between V<sub>S</sub> and GND: Needed for micro cuts in power supply



Type	Marking	Ordering Code	Package
TLE4926C-HT E6547	26D8	SP000718258	PG-SSO-3-92

<sup>1</sup> value of capacitor: 47nF±10%; (excluded drift due to temperature and over lifetime); ceramic: X8R; maximum voltage: 50V.

## General Information

The TLE4926C-HT E6547 is an active Hall sensor suited to detect the motion and position of ferromagnetic and permanent magnet structures. An additional self-calibration module has been implemented to achieve optimum accuracy during normal running operation. It comes in a three-pin package for the supply voltage and an open drain output.

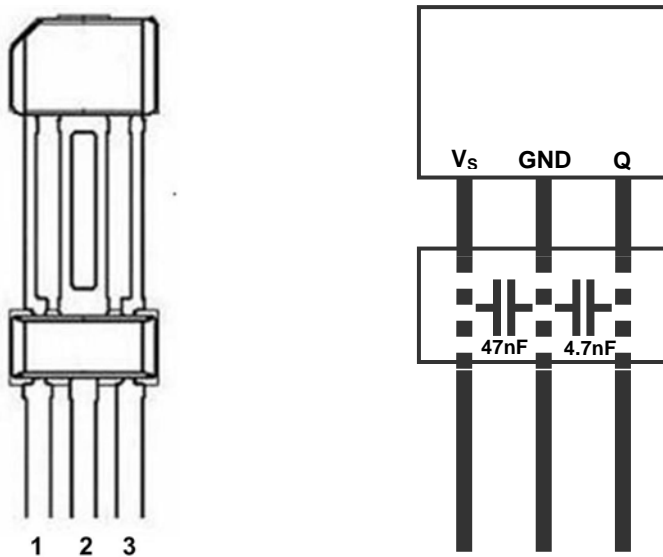


Figure 1: Pin configuration PG-SSO-3-92

## Pin definition and Function

Pin No.	Symbol	Function
1	$V_s$	Supply Voltage
2	GND	Ground
3	Q	Open Drain Output

## Functional Description

The differential Hall sensor IC detects the motion and position of ferromagnetic and permanent magnet structures by measuring the differential flux density of the magnetic field. To detect ferromagnetic objects the magnetic field must be provided by a back biasing permanent magnet (south or north pole of the magnet attached to the rear unmarked side of the IC package).



Offset cancellation is achieved by advanced digital signal processing. Immediately after power-on motion is detected (start-up mode). After a few transitions the sensor has finished self-calibration and switches to a high-accuracy mode (running mode). In running mode switching occurs at signal zero-crossing of the arithmetic mean of max and min value of magnetic differential signal.  $\Delta B$  is defined as difference between hall plate 1 and hall plate 2.

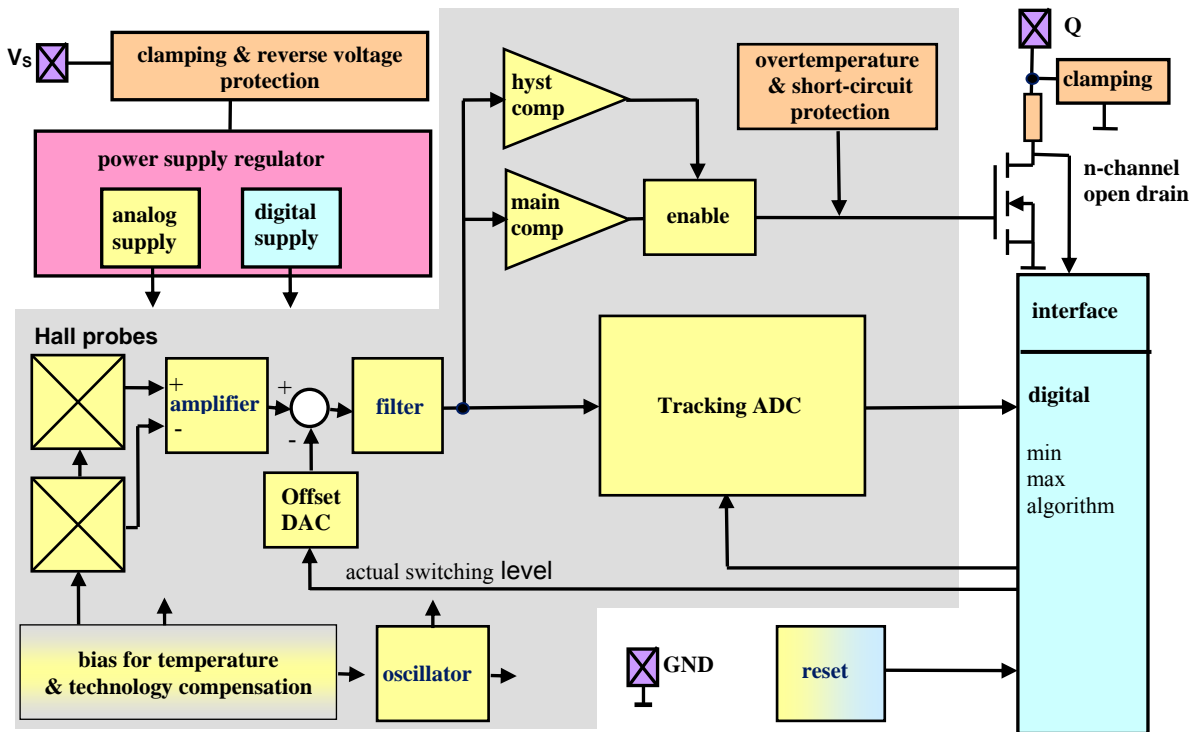


Figure 2: Block diagram of TLE4926C-HT E6547

### Circuit Description

The TLE4926C-HT E6547 is comprised of a supply voltage regulator, a pair of hall probes, spaced at 2.5mm, differential amplifier, noise-shaping filter, comparator, advanced digital signal processor (DSP), A/D and D/A converter and an open drain output.

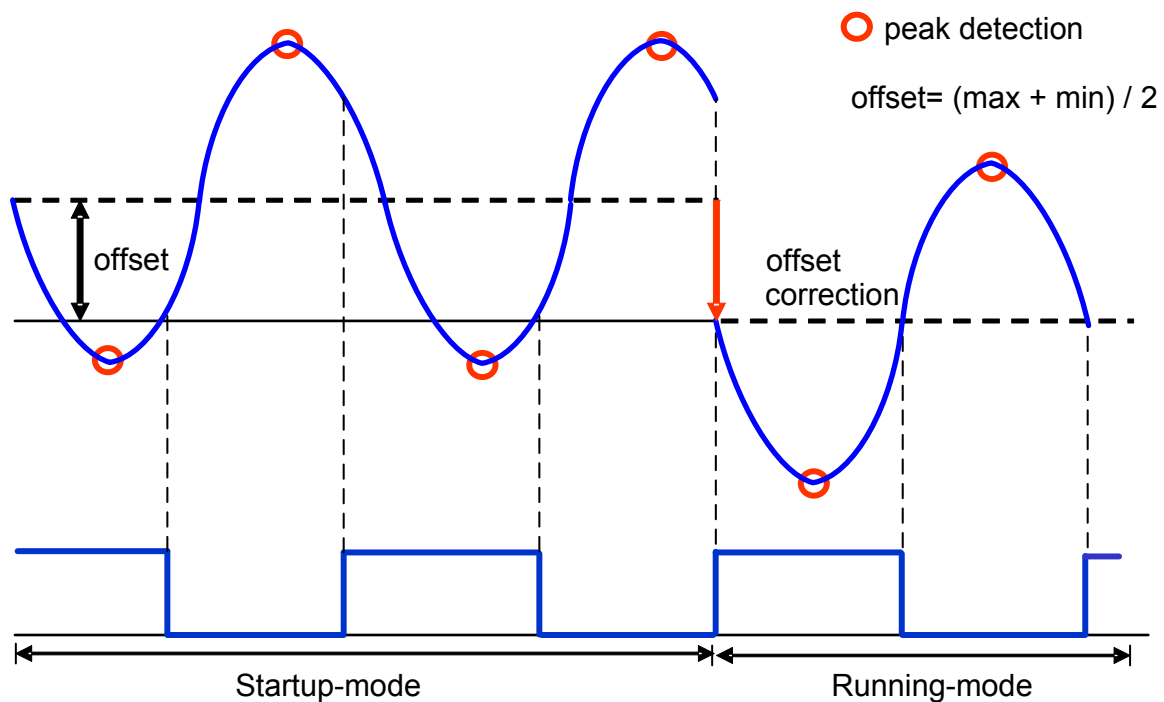
#### Startup mode:

The differential signal is digitized in the A/D converter and fed into the dsp part of the circuit. There a rising or falling transition is detected and the output stage is triggered accordingly. As the signal is not offset compensated at this time, the output does not necessarily switch at zero-crossing of the magnetic signal. Signal peaks are also detected in the digital circuit and their arithmetic mean value can be calculated. The offset of this mean value is determined and fed into the offset

cancellation DAC. This procedure can be repeated with increasing accuracy. After few increments the IC is switched into the high accuracy running mode.

*Running mode:*

In running mode the output is triggered by the comparator. An offset cancellation feedback loop is formed by the A/D converter, dsp and offset cancellation D/A converter. In running mode switching always occurs at zero-crossing. It is only affected by the (small) remaining offset of the comparator and by the remaining propagation delay time of the signal path, mainly determined by the noise-shaping filter. Nevertheless signals below a defined threshold are not detected to avoid unwanted parasitic switching.



**Figure 3: Startup of the device**

At transition from startup-mode to running mode switching timing is moving from low-accuracy to high accuracy zero-crossing.

## 1.1 Absolute Maximum Ratings

No.	Parameter	Symbol	min	Typ	max	Unit	Remarks
1.1.1	Supply voltage	$V_S$	-18 -24 -26 -28		18 24 26 28	V V V V	- 1h with $R_{Series} \geq 200\Omega^2$ 5min with $R_{Series} \geq 200\Omega^2$ 1min with $R_{Series} \geq 200\Omega^2$
1.1.2	Supply current	$I_S$	-10		25	mA	-
1.1.3	Output OFF voltage	$V_Q$	-0.3 -18 -18 -1.0		18 24 26 -	V V V V	- 1h with $R_{Load} \geq 500\Omega$ 5min with $R_{Load} \geq 500\Omega$ 1h (protected by internal series resistor)
1.1.4	Output ON voltage	$V_Q$	- - -		16 18 24	V V V	Current internal limited by short circuit protection (72h @ $T_A < 40^\circ\text{C}$ ). Current internal limited by short circuit protection (1h @ $T_A < 40^\circ\text{C}$ ). Current internal limited by short circuit protection (1min @ $T_A < 40^\circ\text{C}$ ).
1.1.5	Continuous output current	$I_Q$	-50		50	mA	-
1.1.6	Junction temperature	$T_j$	-40		155 165 175 195	$^\circ\text{C}$ $^\circ\text{C}$ $^\circ\text{C}$ $^\circ\text{C}$	- 5000h (not additive) 2500h (not additive) 500 h (not additive) 10 x1 h (additive to the other life times).
1.1.7	Storage temperature	$T_S$	-40		150	$^\circ\text{C}$	-
1.1.8	Thermal resistance junction-air for PG-SSO-3-92	$R_{th JA}$			190	K/W	Lower values are possible with overmoulded devices.

*Note: Stresses above those listed here may cause permanent damage to the device. Exposure to absolute maximum rating conditions for extended periods may affect device reliability.*

<sup>2</sup> Accumulated life time.

## 1.2 ESD Protection

No.	Parameter	Symbol		max	Unit	Remarks
1.2.1	ESD – protection PG-SSO-3-92	$V_{ESD}$		$\pm 6$	kV	According to standard EIA/JESD22-A114-B Human Body Model (HBM 1500 Ohm/100pF)

## 2.1 Operating Range

No.	Parameter	Symbol	min	typ	max	Unit	Remarks
2.1.1	Supply voltage	$V_S$	3.2		18	V	Continuous
					24	V	1h with $R_{Series} \geq 200\Omega$
					26	V	5min with $R_{Series} \geq 200\Omega$ . Extended limits for parameters in characteristics.
			3			V	During test pulse 4. Limited performance possible
2.1.2	Supply voltage ripple	$V_{SAC}$			6	$V_{pp}$	$V_S=13V$ ; $0 < f < 50kHz$
2.1.3	Continuous output OFF voltage	$V_Q$	0		18	V	Continuous
					24	V	1h with $R_{Load} \geq 500\Omega$
2.1.4	Continuous output ON current	$I_Q$	0		20	mA	$V_{Qmax}=0.6V$
2.1.5	Power on time	$t_{on}$			1.0	ms	Time to achieve specified accuracy After power on the output of the IC is always in high-state. After internal resets output is locked <sup>3</sup> .

<sup>3</sup> Output of the IC is locked in present state (high-state or low-state) after an internal reset is launched. This reset happens typically every 780ms when there is no output switching in either case. See also 2.2.14. A voltage reset causes a release of the output and output is in high state after power on again.

2.1.6	Operating junction temperature	$T_j$	-40			°C	-
					155	°C	5000 h (not additive)
					165	°C	2500 h (not additive)
					175	°C	500 h (not additive) reduced signal quality permissible (e.g. jitter)

*Note: Unless otherwise noted, all temperatures refer to junction temperature. For the supply voltage lower than 28V ( $R_{Series} \geq 200\Omega$ ) and junction temperature lower than 195°C the magnetic and AC/DC characteristics can exceed the specification limits.*

## 2.2 AC/DC Characteristics

Over operating range, unless otherwise specified. Typical values correspond to  $V_S=12V$  and  $T_A=25^\circ C$

No.	Parameter	Symbol	min	typ	max	Unit	Remarks
2.2.1	Supply current	$I_S$	3	6.8	9	mA	-
2.2.2	Supply current @ 3.2V	$I_{SVmin}$	3	6.7	8.5	mA	$V_S=3.2V$
2.2.3	Supply current @ 24V	$I_{Smax}$	3	7	9.5	mA	$V_S=24V$ $R_{Series} \geq 200\Omega$
2.2.4	Output saturation voltage	$V_{Qsat}$		0.25	0.6	V	$I_Q=20mA$
2.2.5	Output leakage current	$I_{Qleak}$		0.1	10	$\mu A$	$V_Q=18V$
2.2.6	Current limit for short-Circuit protection	$I_{Qshort}$	30	60	80	mA	-
2.2.7	Junction temperature limit for output protection	$T_{prot}$	195	210	230	°C	-
2.2.8	Output rise time	$t_r^4$	4	12	20	$\mu s$	$V_{Load} = 4.5$ to $24V$ $R_{Load} = 1.2k\Omega$ ; $C_{Load} = 4.7nF$ included in package.

<sup>4</sup> value of capacitor:  $4.7nF \pm 10\%$ ; (excluded drift due to temperature); ceramic: X8R; maximum voltage: 50V. The rise time is defined as the time between the 10 and 90% value.

2.2.9	Output fall time	$t_f^5$	0.5 0.65	0.9 1.15	1.3 1.65	$\mu\text{s}$ $\mu\text{s}$	$V_{\text{Load}} = 5\text{V}$ $V_{\text{Load}} = 12\text{V}$ $R_{\text{Load}} = 1.2\text{k}\Omega$ ; $C_{\text{Load}} = 4.7\text{nF}$ included in package
2.2.10	delay time Falling edge Rising edge	$t_d$	7	12.5	18 <sup>6</sup> 20 25 <sup>7</sup>	$\mu\text{s}$ $\mu\text{s}$	Only valid for $T_j=25^\circ\text{C}$ . $T_j=-40^\circ\text{C} - T_j=175^\circ\text{C}$ $T_j=-40^\circ\text{C} - T_j=175^\circ\text{C}$ Higher magnetic slopes and overshoots reduce $t_d$ , because the signal is filtered internal. <sup>8</sup>
2.2.11	Temperature drift of delay time of output to magnetic edge	$\Delta t_d$	-6	3 <sup>9</sup>	6	$\mu\text{s}$	Time over specified temperature range; not additional to $t_d$
2.2.12	Frequency range	f	0.001		8	kHz	Operation below $1\text{Hz}^{10}$
2.2.13	Oscillator frequency	$f_{\text{OSC}}$		1.34		MHz	-
2.2.14	Offset recalibration time after last output change	$t_{\text{reset}}$	625	780	970	ms	Output locked to state before recalibration
2.2.15	Clamping voltage $V_{\text{S-clamp}}$	$V_{\text{S-clamp}}$	24	27.5		V	1 mA through clamping device
2.2.16	Clamping voltage Q-pin	$V_{\text{Q-clamp}}$	24	27.5		V	1 mA through clamping device
2.2.17	Analog reset voltage	$V_{\text{sReset}}$		2.35	2.9	V	-

*Note: The listed AC/DC and magnetic characteristics are ensured over the operating range of the integrated circuit. Typical characteristics specify mean values expected over the production spread. If not other specified, typical characteristics apply at  $T_j = 25^\circ\text{C}$  and  $V_S = 12\text{V}$ .*

<sup>5</sup> see footnote 4.

<sup>6</sup> only valid for the falling edge.

<sup>7</sup> Not subject to production test-verified by design/characterisation

<sup>8</sup> measured with a sinusoidal-field with  $10\text{mTpp}$  and a frequency of  $1\text{kHz}$ .

<sup>9</sup> related to  $T_j = 175^\circ\text{C}$ .

<sup>10</sup> output will switch if magnetic signal is changing more that  $2x |\Delta B_{\text{min}}|$  within offset recalibration time even below  $1\text{Hz}$  once per magnetic edge, increased phase error is possible



## 2.3 Magnetic Characteristics in Running Mode

No.	Parameter	Symbol	min	typ	max	Unit	Remarks
2.3.1	Bias preinduction	$B_0$	-500		500	mT	-
2.3.2	Differential bias induction	$\Delta B_0$	-30		30	mT	-
2.3.3	Minimum signal amplitude	$ \Delta B_{\min} $ <sup>11</sup>	0.55		1.5	mT	
2.3.4	Maximum signal amplitude	$ \Delta B_{\max} $			100	mT	Additional to $B_0$ <sup>12</sup>
2.3.5	Resistivity against mechanical stress (piezo)	$ \Delta B_{\min} $	-0.2		0.2	mT	F= 2N

*Note: The listed characteristics are ensured over the operating range of the integrated circuit. Typical characteristics specify mean values expected over the production spread. If not otherwise specified, typical characteristics apply at  $T_j=25^\circ\text{C}$  and the given supply voltage.*

## 3.1 Self-calibration Characteristics

No.	Parameter	Symbol	min	typ	max	Unit	Remarks
3.1.1	No. of magnetic edges for first output switching	$n_{\text{Start}}$			2	-	latest 2 <sup>nd</sup> magnetic edge will cause output switching
3.1.2	No. of magnetic edges to enter calibrated mode	$n_{\text{Calib}}$			6	-	Low phase accuracy permitted. See 3.1.7 7 <sup>th</sup> edge with high accuracy. Valid for sinusoidal signal without noise influence
3.1.3	Duty cycle in running mode <sup>13</sup>	Dty	45	50	55	%	$\Delta B_{\text{pp}} = 10\text{mT}$ ideal sinusoidal input signal ( $T_j=25^\circ\text{C}$ )
			40	50	60	%	$\Delta B_{\text{pp}} = 10\text{mT}$ ideal sinusoidal input signal ( $-40^\circ\text{C} \leq T_j < 175^\circ\text{C}$ )

<sup>11</sup>  $|\Delta B_{\min}|$  refers to 50 % criteria: 50 % of output pulses are lost, sinusoidal input signal

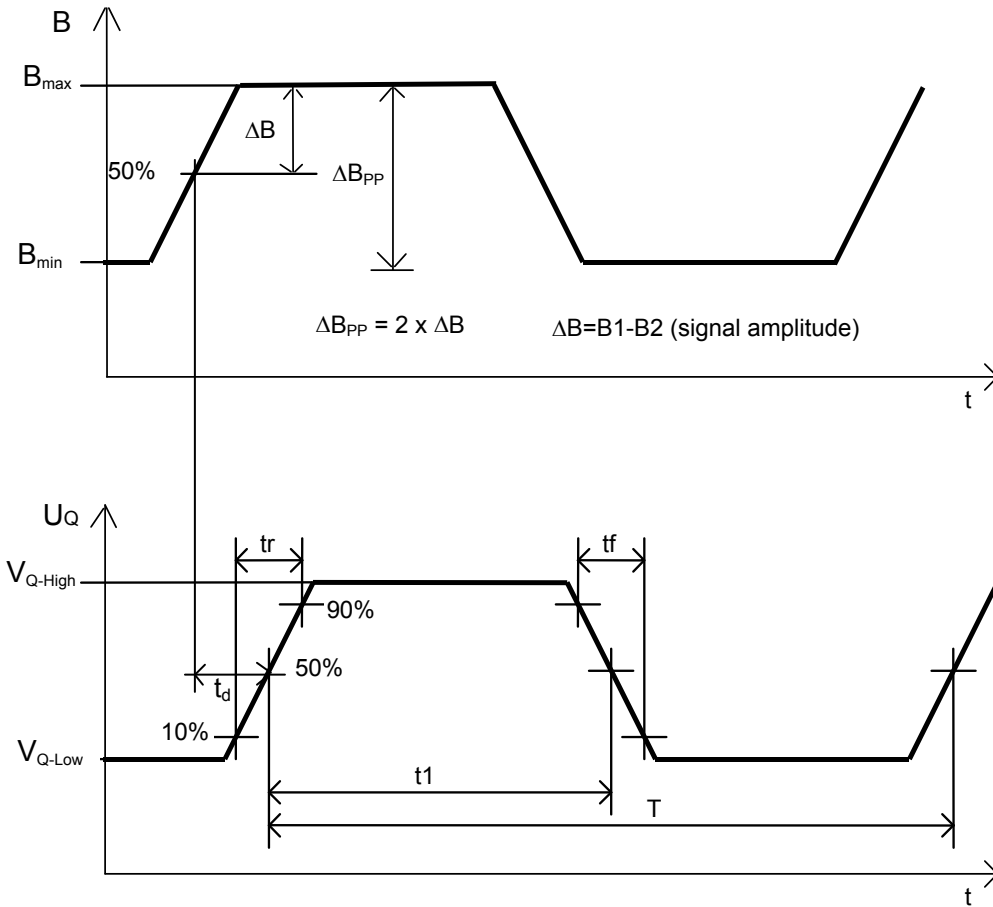
<sup>12</sup> exceeding this limit might result in decreased duty cycle performance. With higher values the internal measured signal will be clipped. This will decrease the phase accuracy.

<sup>13</sup> this corresponds to a  $\Delta B_0 = 0\text{mT}$  (magnetic offset).

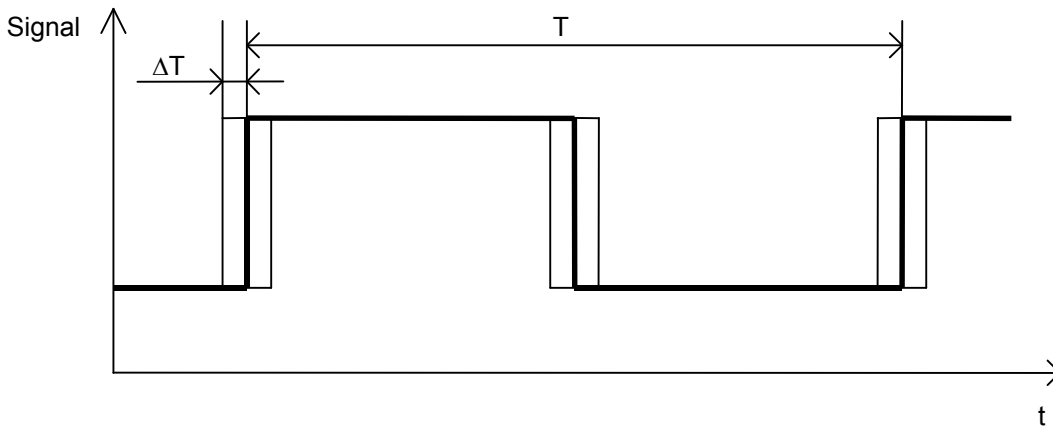
3.1.4	Signal jitter in running mode; 1 sigma value <sup>6</sup>	$\sigma 1$		$\leq \pm 0.11^{14}$		%	$\Delta B_{pp} = 10\text{mT}$ ideal sinusoidal input signal; $T_j < 150^\circ\text{C}$
		$\sigma 2$		$\leq \pm 0.16$		%	$\Delta B_{pp} = 10\text{mT}$ ideal sinusoidal input signal; $150^\circ\text{C} \leq T_j < 175^\circ\text{C}$
3.1.5	Signal Jitter in running mode at power supply of $V_s = 13\text{V}$ and ripple $\pm 3\text{V}$ ; 1 sigma value <sup>6</sup>	$\sigma 3$		$\leq \pm 0.11$		%	$\Delta B_{pp} = 10\text{mT}$ ideal sinusoidal input signal; $T_j < 150^\circ\text{C}$
3.1.6	Effective noise value of the magnetic switching points, 1 sigma value	$B_{\text{neff}}$		25		$\mu\text{T}$	$T_j = 25^\circ\text{C}$ ; The magnetic noise is normal distributed, nearly independent to frequency and without sampling noise or digital noise effects. The typical value represents the rms-value here and corresponds therefore to $1\sigma$ probability of normal distribution. Consequently a $3\sigma$ value corresponds to 0.3% probability of appearance.
							70
3.1.7	Uncalibrated phase error Magnetic edge 1-2 After 3 <sup>rd</sup> edge Magnetic edge 1-3					°	Related to calibrated switching behaviour. $\Delta B_{pp} = 10\text{mT}$ ideal sinusoidal input signal <sup>15</sup> Magnetic fields close to $2x  \Delta B_{\text{min}} $

<sup>14</sup> depends largely on  $|\Delta B_{\text{min}}|$  magnetic signal steepness and also on frequency.

<sup>15</sup> smaller phase errors are possible at higher signal amplitudes, because sinus signal changes to a more rectangle signal.



**Figure 4 Switching direction**



$$\sigma_1 \dots \sigma_3 = \frac{1}{T} \cdot \sqrt{\frac{1}{(n-1)} \cdot \sum (\Delta T)^2}$$

measurement condition:  $n \geq 1000$

**Figure 5 Definition of signal jitter**

## Application Configurations

Two possible applications are shown in **Figure 8** and **Figure 9** (Toothed and Magnet Wheel).

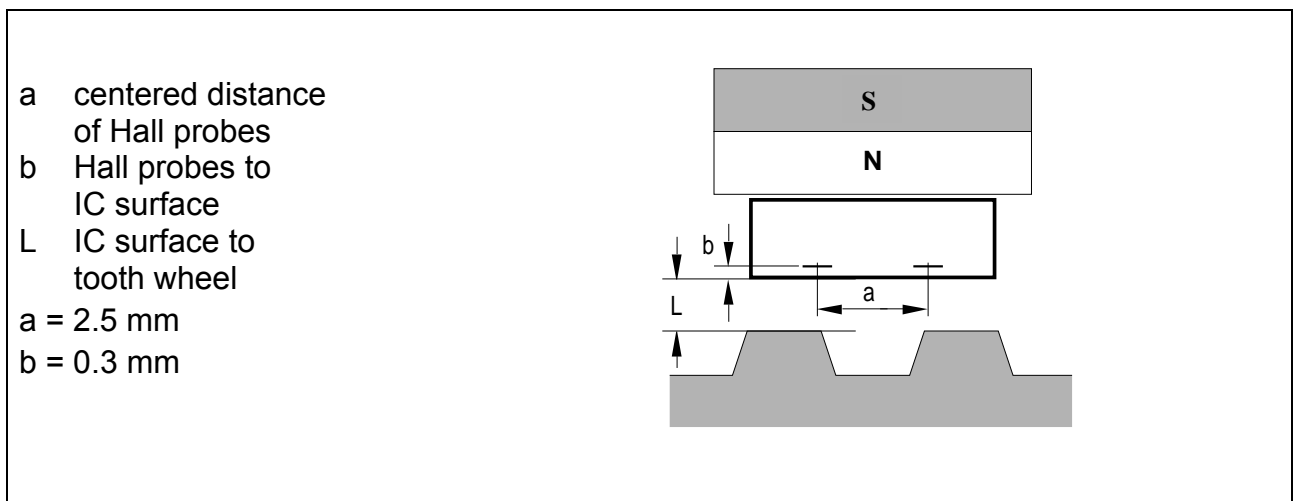
The difference between two-wire and three-wire application is shown in **Figure 10**.

### Gear Tooth Sensing

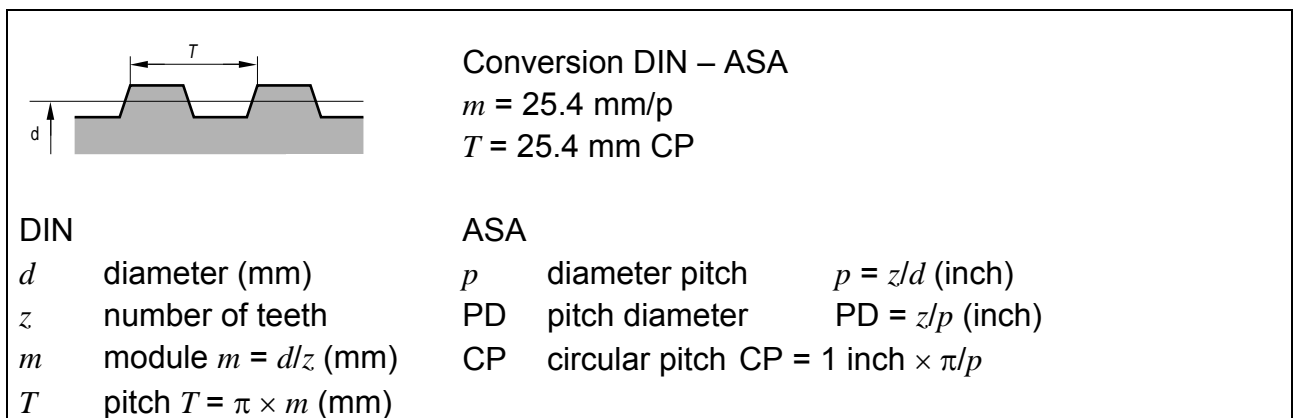
In the case of ferromagnetic toothed wheel application the IC has to be biased by the south or north pole of a permanent magnet (e.g. SmCO<sub>5</sub> (Vacuumschmelze VX145)) with the dimensions 8 mm × 5 mm × 3 mm) which should cover both Hall probes.

The maximum air gap depends on

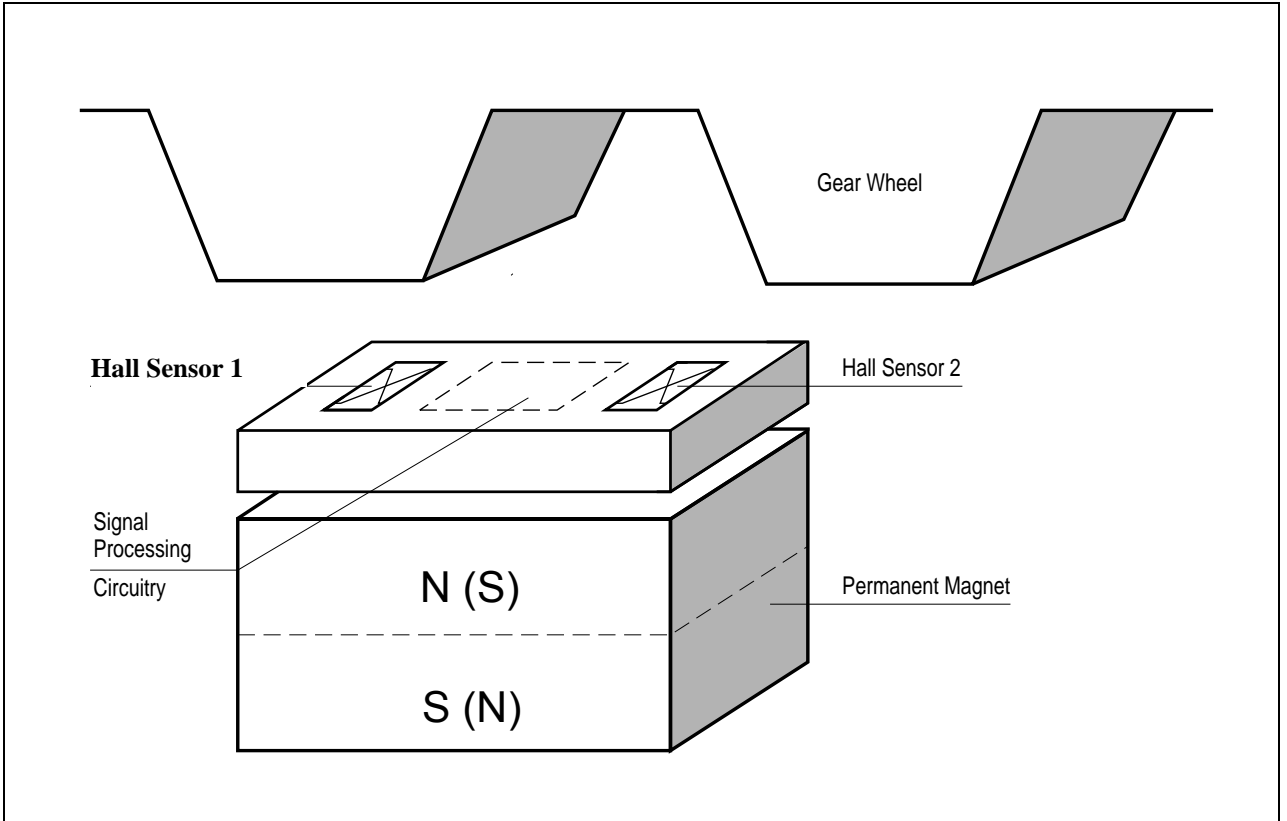
- the magnetic field strength (magnet used; pre-induction) and
- the toothed wheel that is used (dimensions, material, etc.; resulting differential field).



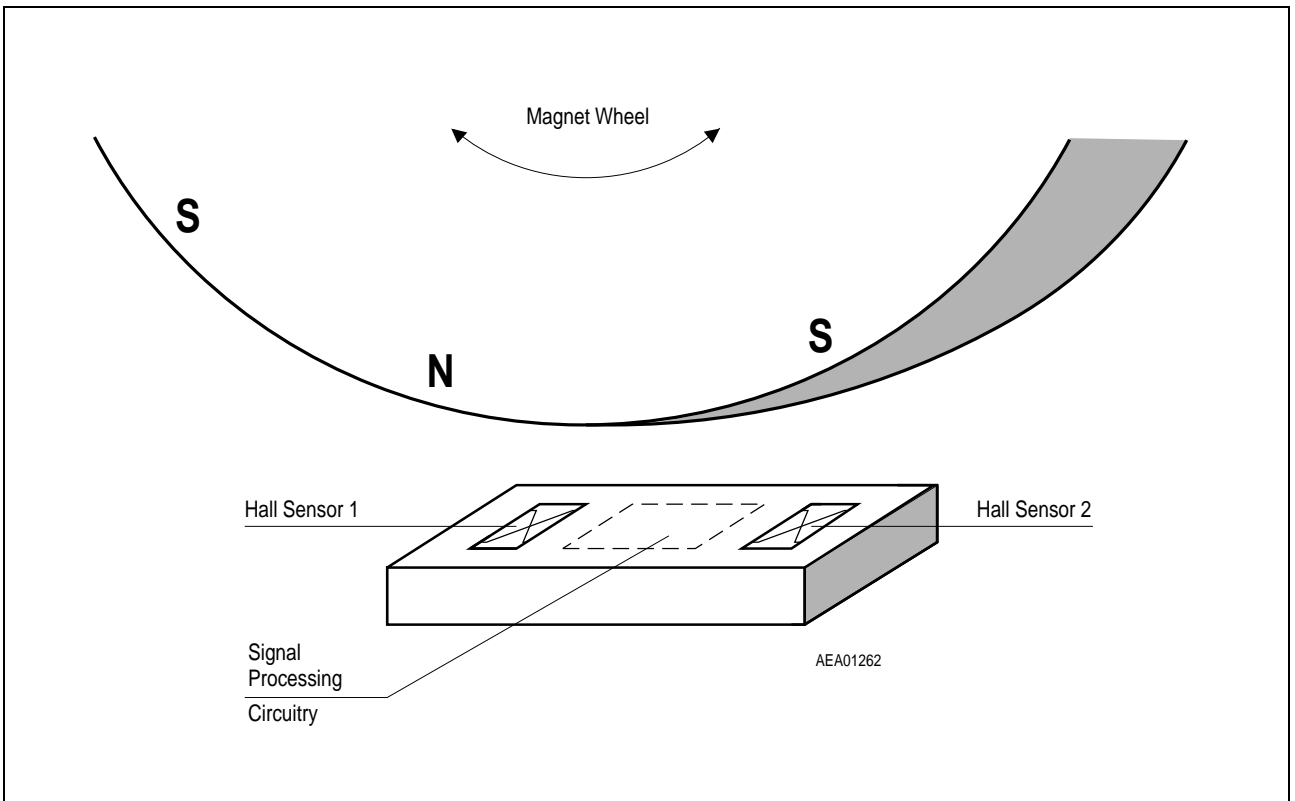
**Figure 6** Sensor spacing



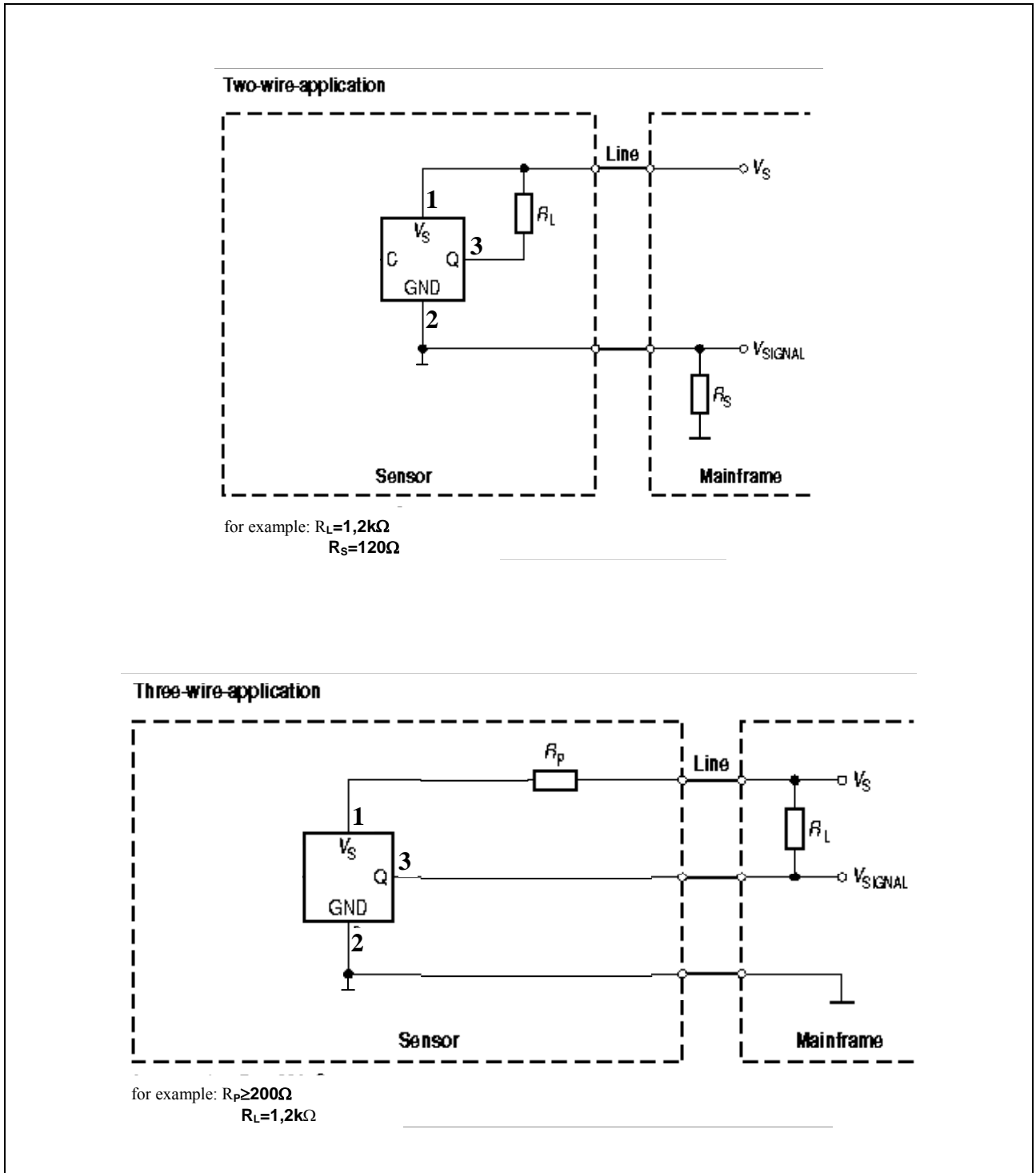
**Figure 7** Toothed wheel dimensions



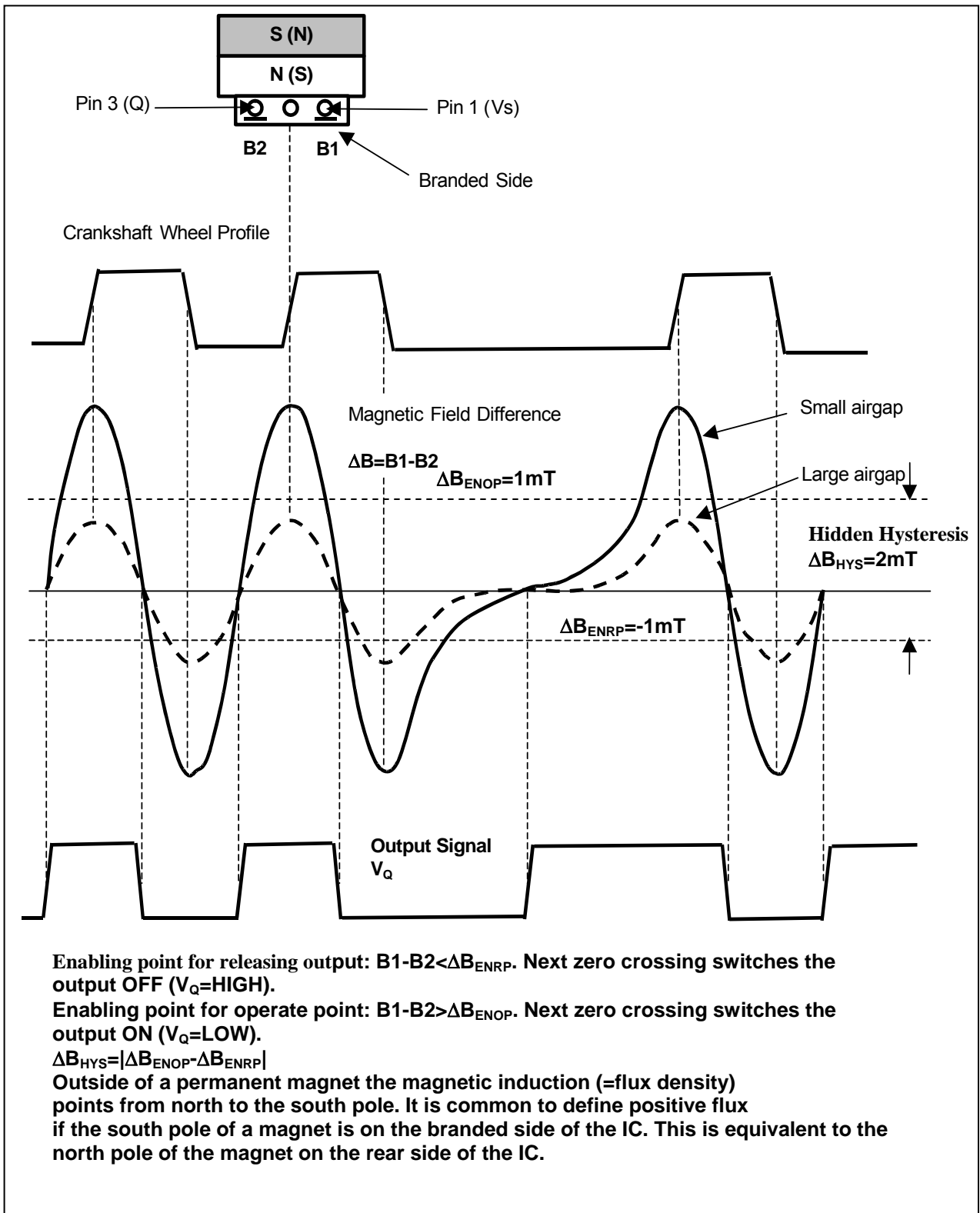
**Figure 8** TLE4926C-HT E6547, with ferromagnetic toothed wheel



**Figure 9** TLE4926C-HT E6547, with magnet wheel

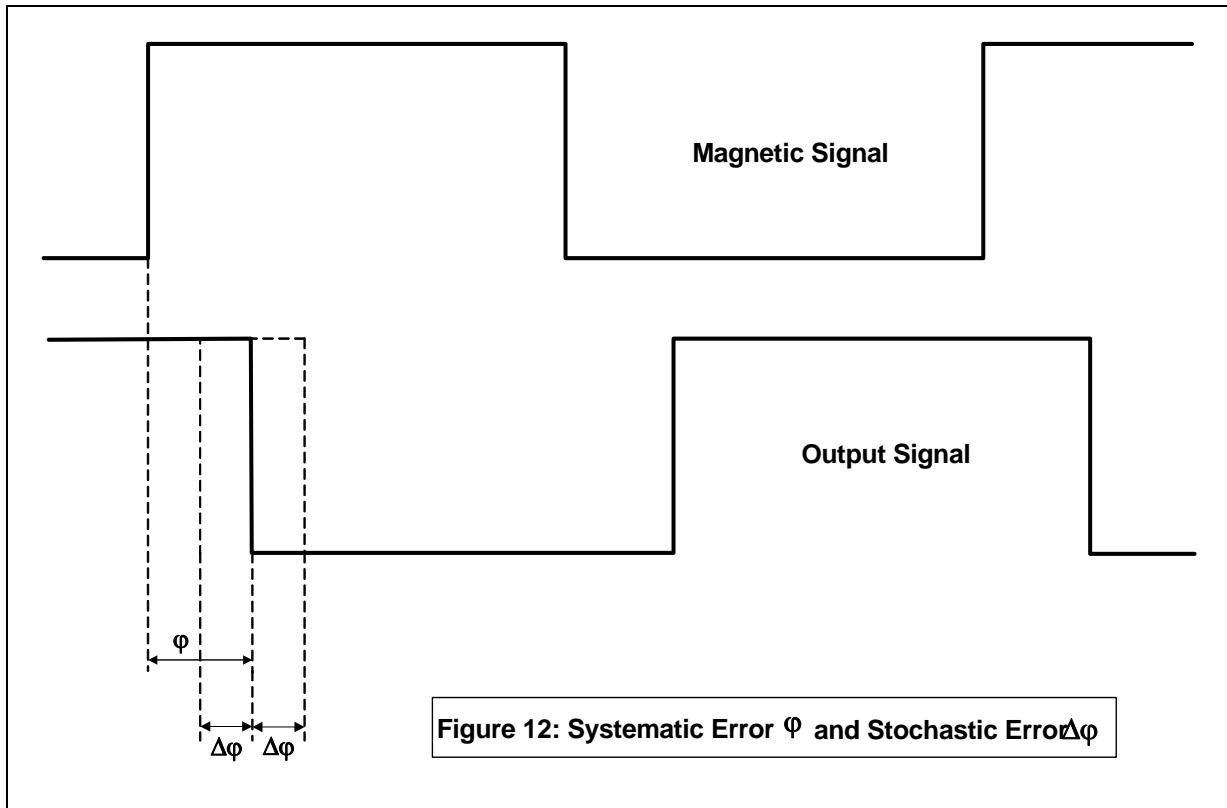


**Figure 10 Application circuits TLE4926C-HT E6547 (capacitors included in package)**



**Figure 11 System operation with hidden hysteresis**

## Appendix: Calculation of mechanical errors:



### Systematic Phase Error $\varphi$

The systematic error comes in because of the delay-time between the threshold point and the time when the output is switching. It can be calculated as follows:

$$\varphi = \frac{360^\circ \cdot n}{60} \cdot t_d$$

- $\varphi$  ... systematic phase error in  $^\circ$
- $n$  ... speed of the camshaft-wheel in  $min^{-1}$
- $t_d$  ... delay time (see specification) in  $sec$



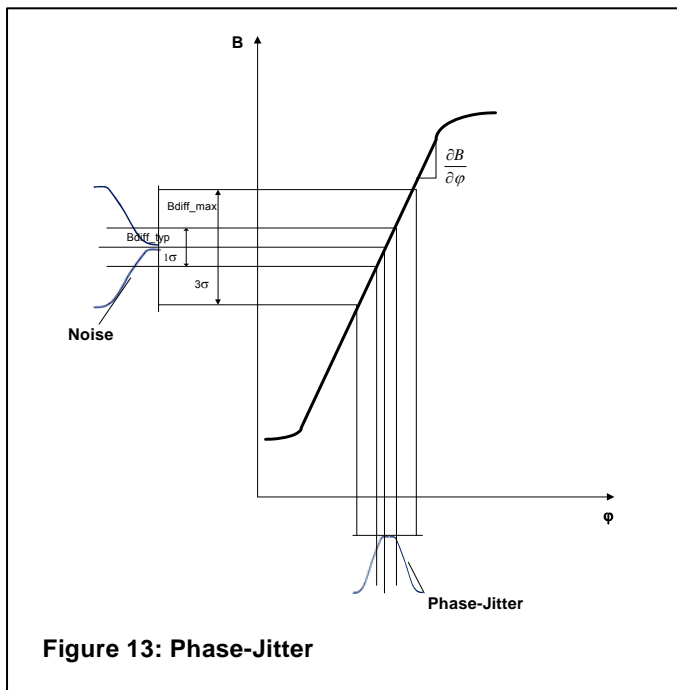
## Systematic Phase Error $\Delta\varphi$

The systematic phase error includes the error due to the variation of the delay time with temperature and the error caused by the resolution of the threshold. It can be calculated in the following way:

$$\Delta\varphi_d = \frac{360^\circ \cdot n}{60} \cdot \Delta t_d$$

- $\Delta\varphi_d$  ... systematic phase error due to the variation of the delay time over temperature in  $^\circ$
- $n$  ... speed of the camshaft wheel in  $min^{-1}$
- $\Delta t_d$  ... variation of delay time over temperature in sec

## Jitter (Repeatability)



The phase jitter is normally caused by the analogue system noise. If there is an update of the offset-DAC due to the algorithm, what could happen after each tooth, then an additional step in the phase occurs (see description of the algorithm). This is not included in the following calculations. The noise is transformed through the slope of the magnetic edge into a phase error. The phase jitter is determined by the two formulas:

$$\varphi_{Jitter\_typ} = \frac{\partial\varphi}{\partial B} \cdot (B_{neff\_typ})$$

$$\varphi_{\text{Jitter\_max}} = \frac{\partial \varphi}{\partial B} \cdot (B_{\text{neff\_max}})$$

$\varphi_{\text{Jitter\_typ}}$	...	typical phase jitter at $T_j=25^\circ\text{C}$ in $^\circ$ (1Sigma)
$\varphi_{\text{Jitter\_max}}$	...	maximum phase jitter at $T_j=175^\circ\text{C}$ in $^\circ$ (3Sigma)
$\frac{\partial \varphi}{\partial B}$	...	inverse of the magnetic slope of the edge in $^\circ/\text{T}$
$B_{\text{neff\_typ}}$	...	typical value of $B_{\text{diff}}$ in $\text{T}$ (1 $\sigma$ -value at $T_j=25^\circ\text{C}$ )
$B_{\text{neff\_max}}$	...	maximum value of $B_{\text{diff}}$ in $\text{T}$ (3 $\sigma$ -value at $T_j=175^\circ\text{C}$ )

## Example:

Assumption:

$n = 4500 \text{ min}^{-1}$
$t_d = 14 \mu\text{s}$
$\Delta t_d = \pm 3 \mu\text{s}$
$\frac{\partial B}{\partial \varphi} = 3 \text{ mT}^\circ$
$B_{\text{neff\_typ}} = \pm 40 \mu\text{T}$ (1 $\sigma$ -value at $T_j=25^\circ\text{C}$ )
$B_{\text{neff\_max}} = \pm 210 \mu\text{T}$ (3 $\sigma$ -value at $T_j=175^\circ\text{C}$ )

Calculation:	$\varphi_d = 0.378^\circ$	...	systematic phase error
	$\Delta\varphi_d = \pm 0.081^\circ$	...	systematic phase error due to delay time
variation	$\varphi_{\text{Jitter\_typ}} = \pm 0.013^\circ$	...	typical phase jitter (1 $\sigma$ -value at $T_j=25^\circ\text{C}$ )
	$\varphi_{\text{Jitter\_max}} = \pm 0.07^\circ$	...	maximum phase jitter (3 $\sigma$ -value at $T_j=175^\circ\text{C}$ )



#### 4.1 Electro Magnetic Compatibility - (values depend on $R_{Series}$ !)

Ref. ISO 7637-2; 2<sup>nd</sup> edition 06/2004; test circuit of figure 14; conducted on supply line

$\Delta B_{PP} = 10\text{mT}$  (ideal sinusoidal signal);  $V_S = 13.5\text{V} \pm 0.5\text{V}$ ,  $f_B = 1000\text{Hz}$ ;  $T = 25^\circ\text{C}$ ;  $R_{Series} \geq 200\Omega$ ;

No.	Parameter	Symbol	Level/typ	Status
4.1.1	Testpulse 1	$V_{EMC}$	IV / -100 V	C
	Testpulse 2a		IV / 50 V	C
	Testpulse 2b		IV / 10 V	C
	Testpulse 3a		IV / -150 V	A <sup>16</sup>
	Testpulse 3b		IV / 100 V	A <sup>16</sup>
	Testpulse 5a		IV / 86.5 V	C
	Testpulse 5b		IV / 86.5V	A <sup>17</sup>

*Note: Test criteria for status A: No missing pulse no additional pulse on the IC output signal plus duty cycle and jitter are in the specification limits.*

*Test criteria for status B: No missing pulse no additional pulse on the IC output signal. (Output signal "OFF" means switching to the voltage of the pull-up resistor).*

*Test criteria for status C: One or more parameter can be out of specification during the exposure but returns automatically to normal operation after exposure is removed.*

*Test criteria for status E: IC destroyed.*

Ref. ISO 7637-3; 1<sup>st</sup> edition 11/1995; test circuit of figure 14; coupling clamp;

$\Delta B_{PP} = 10\text{mT}$  (ideal sinusoidal signal);  $V_S = 13.5\text{V} \pm 0.5\text{V}$ ,  $f_B = 1000\text{Hz}$ ;  $T = 25^\circ\text{C}$ ;  $R_{Series} \geq 200\Omega$ ;

No.	Parameter	Symbol	Level/typ	Status
4.1.2	Testpulse 3a	$V_{EMC}$	IV / -60V	A <sup>16</sup>
	Testpulse 3b		IV / 40V	A <sup>16</sup>

Ref. ISO 11452-3; test circuit of figure 14; measured in TEM-cell;

$\Delta B_{PP} = 4\text{mT}$  (ideal sinusoidal signal);  $V_S = 13.5\text{V} \pm 0,5\text{V}$ ,  $f_B = 200\text{Hz}$ ;  $T = 25^\circ\text{C}$ ;  $R_{Series} \geq 200\Omega$ ;

No.	Parameter	Symbol	Level/max	Remarks
4.1.3	EMC field strength	$E_{TEM-Cell}$	IV / 200V/m	AM=80%, f=1kHz;

*Note: Stresses above those listed here may cause permanent damage to the device. Exposure to absolute maximum rating conditions for extended periods may affect device reliability.*

*Test condition for the trigger window:  $f_{B-field} = 200\text{Hz}$ ,  $B_{pp} = 4\text{mT}$ , vertical limits are  $\pm 10\%$  of  $V_Q$  and horizontal limits are  $\pm 200\mu\text{s}$ .*

<sup>16</sup> Output signal overlaid by burst pulse

<sup>17</sup> Suppressed  $U_s^* = 35\text{V}$

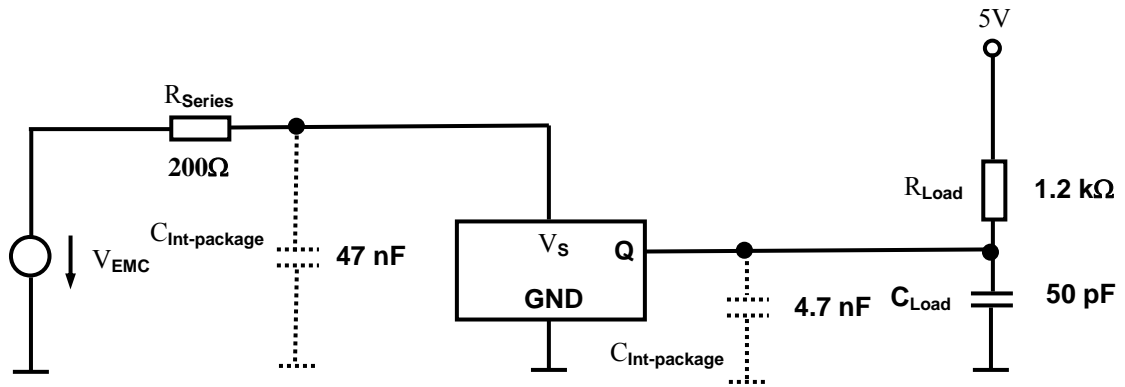
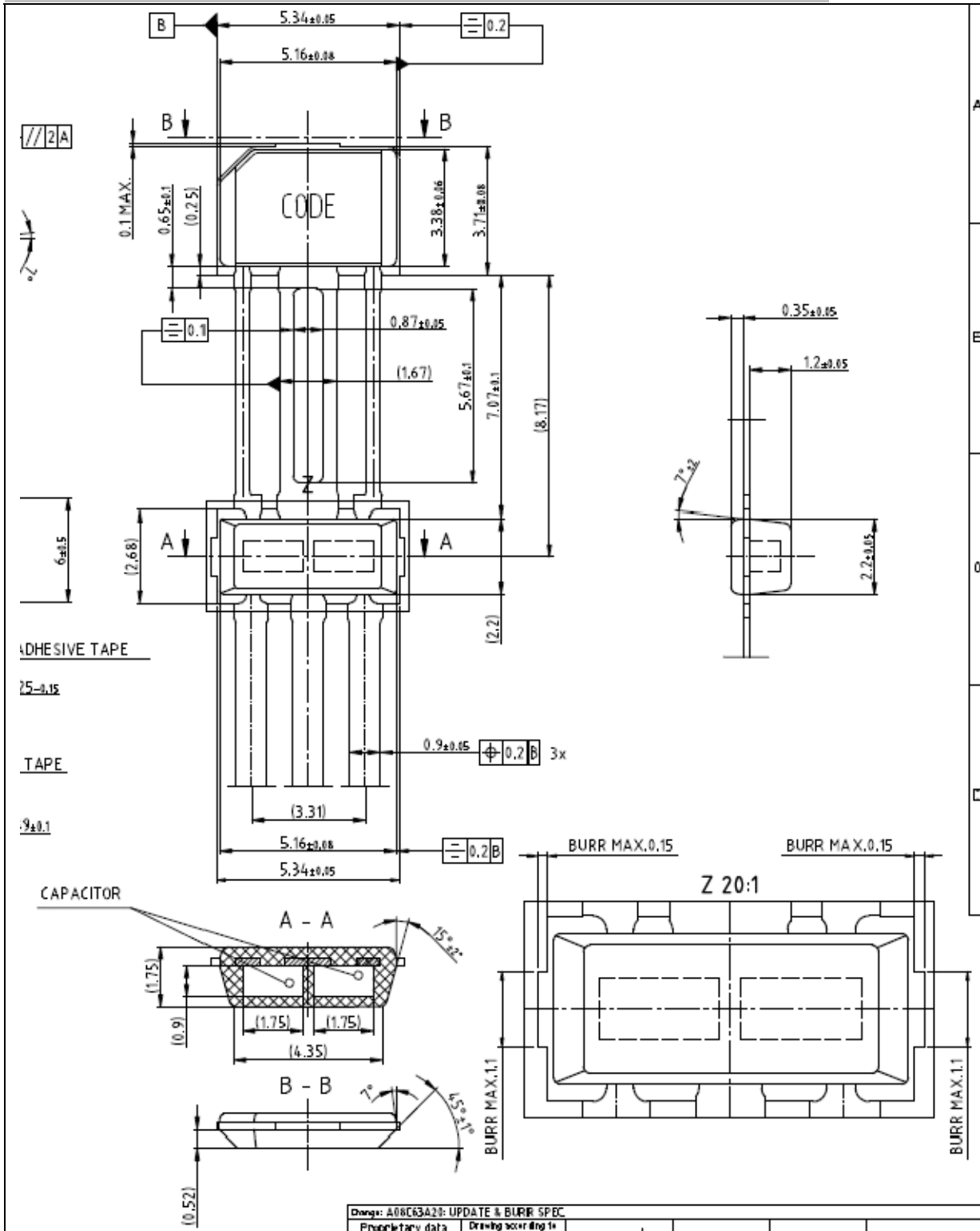
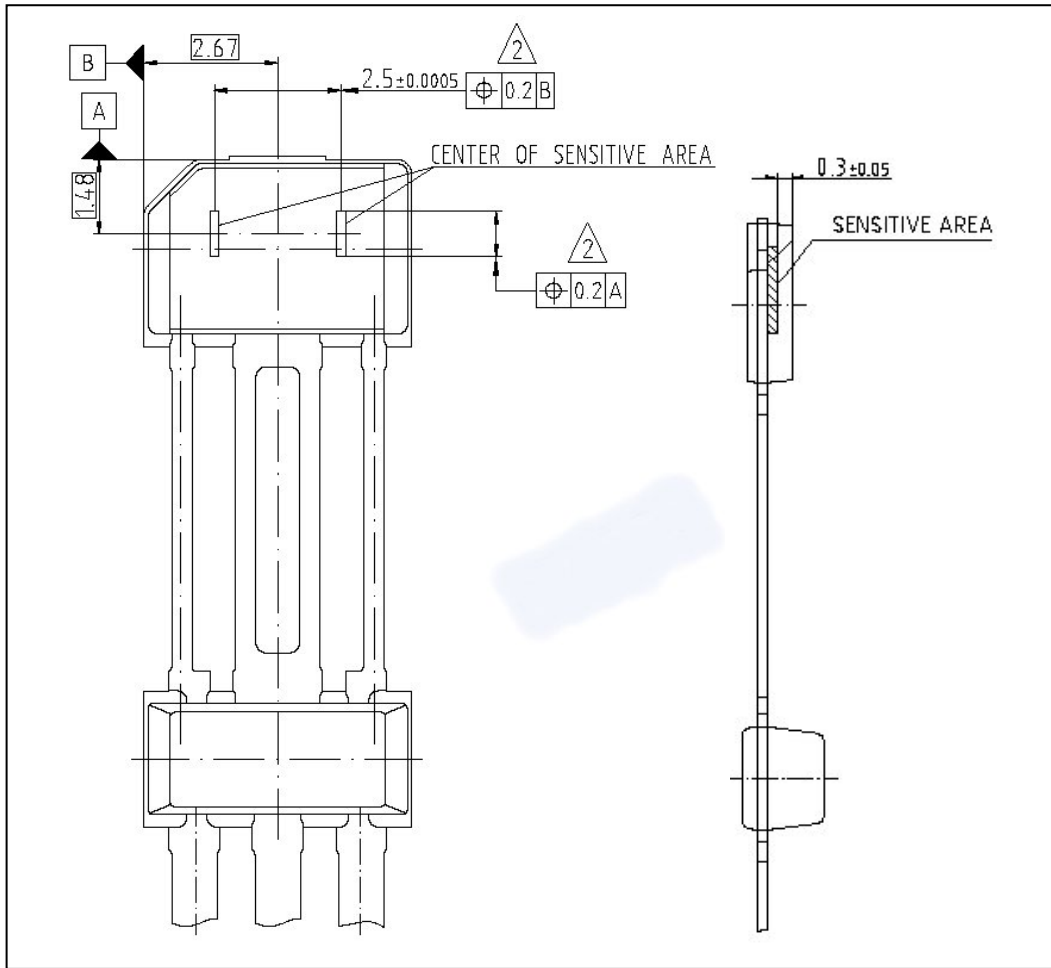


Figure 14: Test circuit for EMC tests

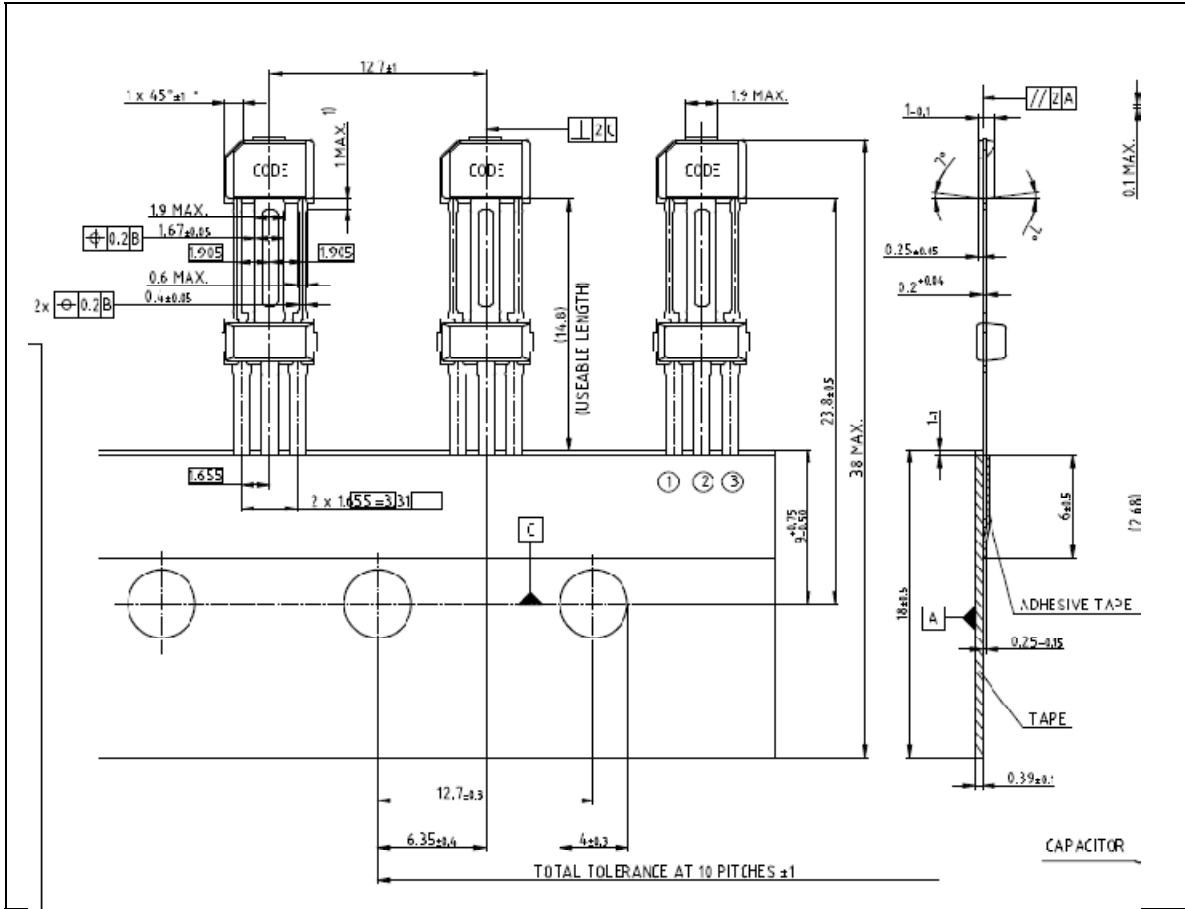
# PG-SSO-3-92 (Plastic Green Single Small Outline)



**Figure 15 Package Dimensions (PG-SSO-3-92)**



**Figure 16** Hall probe spacing in the PG-SSO-3-92 package



**Figure 17** Tape Loading Orientation in the PG-SSO-3-92 package



## **Appendix A: Package information:**

Pure tin covering (green lead plating) is used. Product is RoHS (**R**estriction **o**f **H**azardous **S**ubstances) compliant and marked with letter G in front of the data code marking and may contain a data matrix code on the rear side of the package (see also information note 136/03). Please refer to your key account team or regional sales if you need further information.





Revision History:

February 2011

Version 1.1

<b>Previous Version: 1.0</b>	
Page	Subjects (major changes since last revision)
7	Footnote 4: Maximum capacitor voltage updated

**Infineon Technologies AG**

© Infineon Technologies AIM SC

All Rights Reserved.

<http://www.infineon.com/products/sensors>

**We Listen to Your Comments**

Any information within this document that you feel is wrong, unclear or missing at all?  
Your feedback will help us to continuously improve the quality of this document.  
Please send your proposal (including a reference to this document) to:

**Sensors@infineon.com**

