

20 Programmable LED Driver

FEATURES

- 8-level LED Maximum Current for each LED, max 24.5mA
- Internal ASP with 256x16bit SRAM
- Programmable to Achieve Custom Light Effect
- 256-level Linear/Logarithmic PWM Dimming, 9 bits PWM resolution
- Compatible I²C Interface, V_{IO}: 1.8V ~ 3.3V
- I2C address: 0x2C/0x2D
- Single Power Supply, Voltage Range: 3.0V ~ 4.5V
- QFN 4mmx4mmx0.75mm-28L Package

GENERAL DESCRIPTION

AW9120 integrates a SRAM program-controlled 20 LED driver. 20 LED driver uses common anode current source and PWM dimming. Each LED is 8-level driver current selectable with dimming independently controlled by external MCU or internal 256word*16bit SRAM program.

Compatible I²C interface of 400kHz fast mode is provided. It requires only 3.0V-4.5V single power supply.

APPLICATIONS

Mobile Phones, MID
Portable Media Player
Home Appliances

TYPICAL APPLICATION CIRCUIT

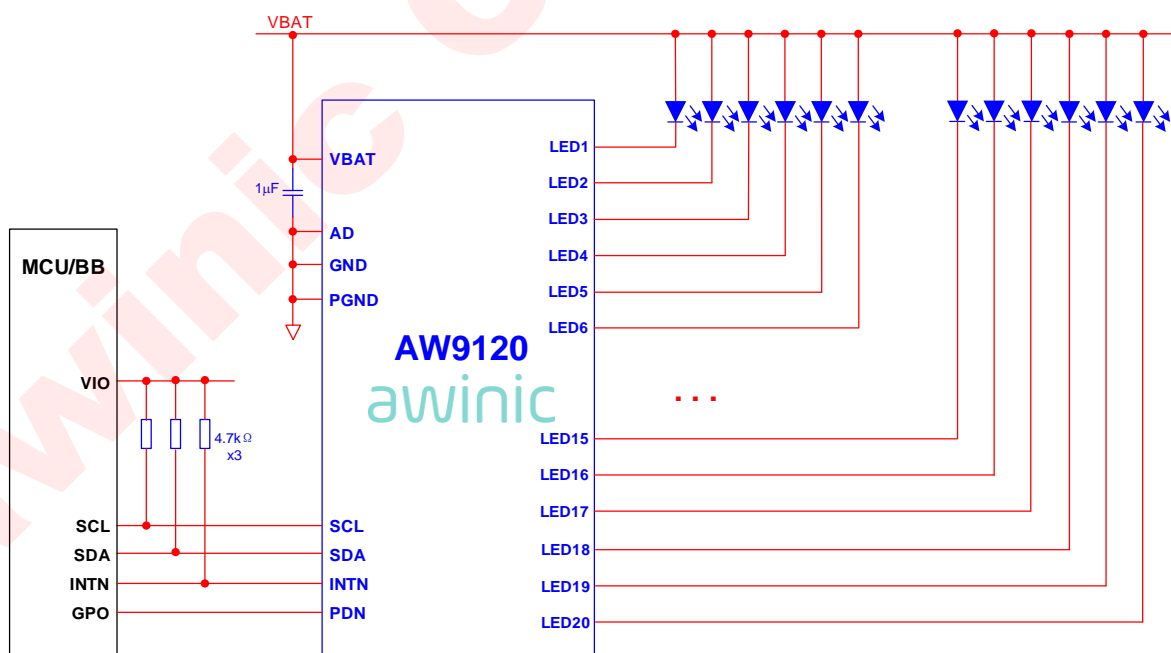

Figure 1 AW9120 Typical Application Circuit

All trademarks are the property of their respective owners.

CONTENT

1	PIN CONFIGURATION AND TOP MARK	4
2	PIN DEFINITION	4
3	FUNCTIONAL BLOCK DIAGRAM	6
4	TYPICAL APPLICATION CIRCUITS	6
5	ORDERING INFORMATION	7
6	ABSOLUTE MAXIMUM RATINGS^(NOTE 3)	7
7	ELECTRICAL CHARACTERISTICS	8
8	I²C INTERFACE TIMING	9
9	FUNCTIONAL DESCRIPTION	10
9.1	WORK MODE	10
9.1.1	POWER ON	10
9.1.2	WORK MODE	10
9.2	RESET	11
9.2.1	HARDWARE RESET	11
9.2.2	SOFTWARE RESET	11
9.3	I ² C INTERFACE	11
9.3.1	DEVICE ADDRESS	11
9.3.2	DATA VALIDATION	11
9.3.3	ACK(ACKNOWLEDGEMENT)	11
9.3.4	I ² C START/STOP	12
9.3.5	WRITE CYCLE	12
9.3.6	READ CYCLE	13
9.4	OSCILLATOR	14
9.5	LED DRIVER	14
9.5.1	LED BRIGHTNESS CONTROLLER	14
9.5.2	LED CONSTANT CURRENT DRIVER	14
9.5.3	ASP	15
10	REGISTER DESCRIPTION	23
10.1	REGISTER CONFIGURATION	23
10.2	GLOBAL REGISTER DESCRIPTION	24
10.2.1	IDRST, CHIP ID AND SOFTWARE RESET	24
10.2.2	GCR, GLOBAL CONTROL REGISTER	24
10.3	LED EFFECT CONTROL REGISTER	24
10.3.1	LER1, LED DRIVER ENABLE REGISTER	24
10.3.2	LER2, LED DRIVER ENABLE REGISTER	24
10.3.3	LCR, LED EFFECT CONFIGURATION REGISTER	24
10.3.4	PMD, PROGRAM MODE REGISTER	25

10.3.5	RMD, PROGRAM RUN MODE REGISTER	25
10.3.6	CTRSR1, LED CONTROL SOURCE SELECTION REGISTER	25
10.3.7	CTRSR2, LED CONTROL SOURCE SELECTION REGISTER	25
10.3.8	IMAX1~IMAX20, LEDX MAXIMUM OUTPUT CURRENT REGISTER.....	25
10.3.9	LISR, LED INTERRUPT STATUS REGISTER.....	26
10.3.10	SADDR, PROGRAM START ADDRESS REGISTER	26
10.3.11	PCR, LED PROGRAM CONTROL POINTER REGISTER	26
10.3.12	CMDR, LED COMMAND REGISTER.....	26
10.3.13	RA/RB/RC/RD,LED INTERNAL PROGRAM REGISTER	26
10.3.14	R1~R8, LED INTERNAL DATA REGISTER	27
10.3.15	GRP, LED GROUP OPERATION REGISTER.....	27
10.3.16	WADDR, LED PROGRAM LOADING ADDRESS REGISTER	27
10.3.17	WDATA, LED PROGRAM LOADING DATA REGISTER	27
10.3.18	WPR, WRITING PROTECTION REGISTER	27
11	TAPE AND REEL INFORMATION.....	28
11.1	CARRIER TAPE.....	28
11.2	PIN1 DIRECTION	28
11.3	REEL.....	29
12	PACKAGE DESCRIPTION	30
13	RECOMMENDED LAND PATTERN.....	30
14	REFLOW.....	31
15	REVISION HISTORY	32
16	DISCLAIMER.....	33

1 PIN CONFIGURATION AND TOP MARK

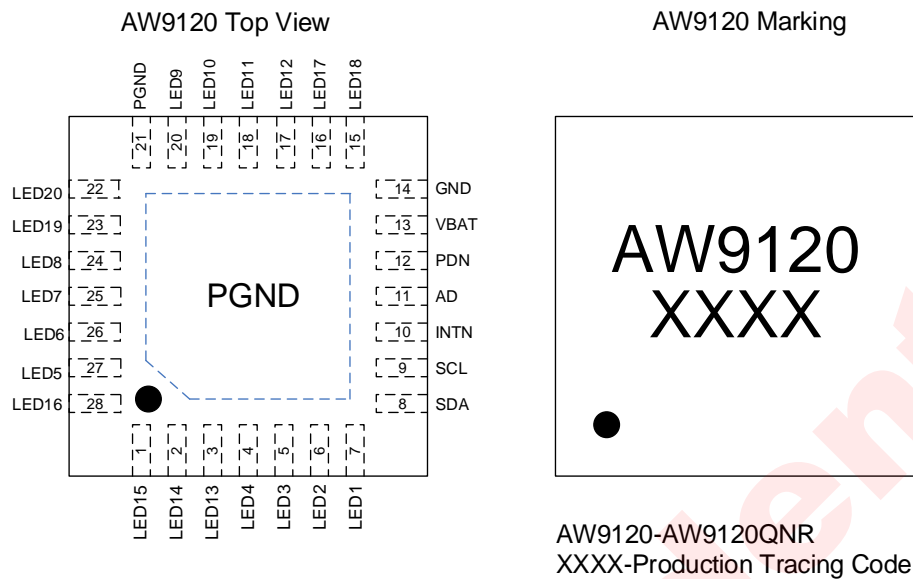

2 PIN DEFINITION

No.	NAME	DESCRIPTION
1	LED15	LED15 cathode driver, anode connected to VBAT
2	LED14	LED14 cathode driver, anode connected to VBAT
3	LED13	LED13 cathode driver, anode connected to VBAT
4	LED4	LED4 cathode driver, anode connected to VBAT
5	LED3	LED3 cathode driver, anode connected to VBAT
6	LED2	LED2 cathode driver, anode connected to VBAT
7	LED1	LED1 cathode driver, anode connected to VBAT
8	SDA	Data I/O of I ² C Interface
9	SCL	Clock input of I ² C Interface
10	INTN	Open-drain Interrupt output, low active. Typically connected to VIO via a 4.7kΩ resistor.
11	AD	I ² C Address Select, internal pull-down resistor
12	PDN	Power-down input , low active, internal 1MΩ pull-down resistor
13	VBAT	Power supply (3.0V to 4.5V)
14	GND	Ground
15	LED18	LED18 cathode driver, anode connected to VBAT
16	LED17	LED17 cathode driver, anode connected to VBAT
17	LED12	LED12 cathode driver, anode connected to VBAT
18	LED11	LED11 cathode driver, anode connected to VBAT
19	LED10	LED10 cathode driver, anode connected to VBAT
20	LED9	LED9 cathode driver, anode connected to VBAT

21	PGND	Ground
22	LED20	LED20 cathode driver, anode connected to VBAT
23	LED19	LED19 cathode driver, anode connected to VBAT
24	LED8	LED8 cathode driver, anode connected to VBAT
25	LED7	LED7 cathode driver, anode connected to VBAT
26	LED6	LED6 cathode driver, anode connected to VBAT
27	LED5	LED5 cathode driver, anode connected to VBAT
28	LED16	LED16 cathode driver, anode connected to VBAT

awinic Confidential

3 FUNCTIONAL BLOCK DIAGRAM

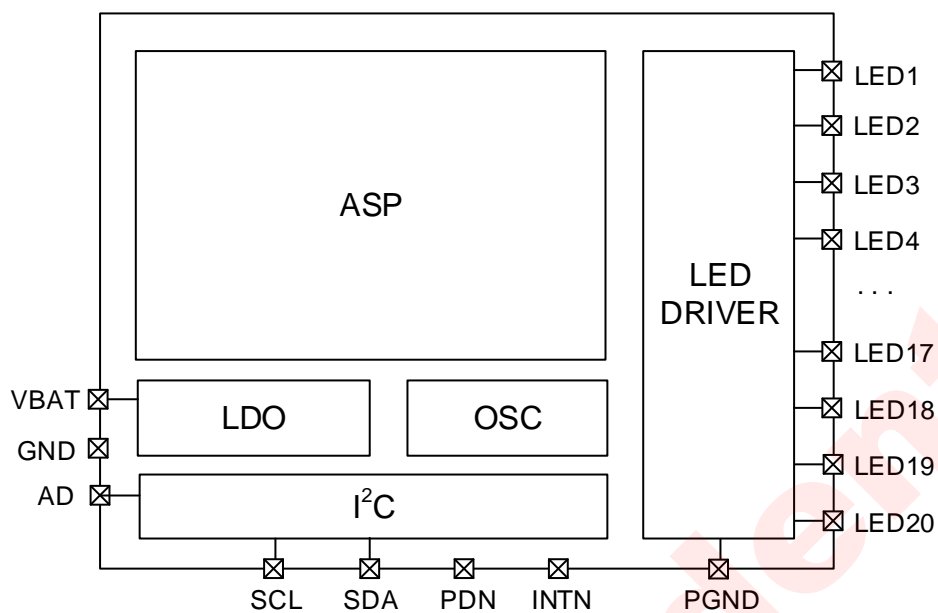

Figure 2 FUNCTIONAL BLOCK DIAGRAM

4 TYPICAL APPLICATION CIRCUITS

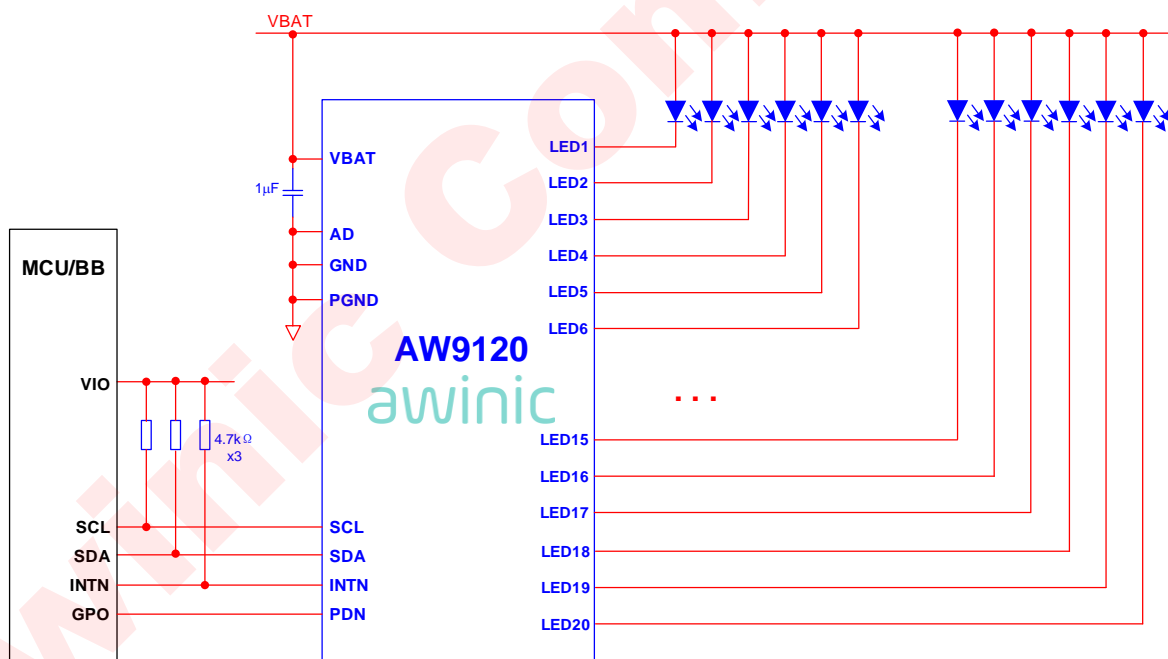
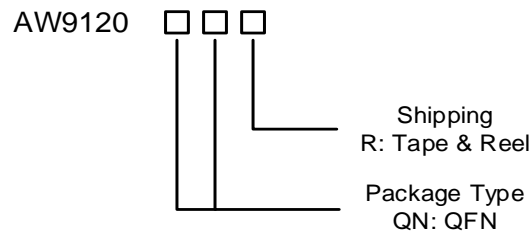

Figure 3 AW9120 Typical Application Circuit

5 ORDERING INFORMATION

Part Number	Temperature	Package	Marking	Moisture Sensitivity Level	Environmental Information	Delivery Form
AW9120QNR	-40°C~85°C	QFN4x4-28L	AW9120	MSL3	ROHS+HF	6000 unit/ Tape and Reel



6 ABSOLUTE MAXIMUM RATINGS^(NOTE 3)

PARAMETERS		RANGE
Supply voltage range V _{BAT}		-0.3V to 5V
Input voltage range	SCL, SDA	-0.3V to 3.6V
	PDN, LED1~LED20	-0.3V to 4.5V
Output voltage range	SDA, INTN	-0.3V to 3.6V
Junction-to-ambient thermal resistance θ_{JA}		45°C/W
Operating free-air temperature range		-40°C to 85°C
Maximum Junction temperature T _{JMAX}		150°C
Storage temperature T _{STG}		-65°C to 150°C
Lead Temperature (Soldering 10 Seconds)		260°C
ESD ^(NOTE 4)		
HBM (human body model)		±4000V
CDM (charge device mode)		±2000V
Latch-up		
Test Condition: JEDEC STANDARD NO.78B DECEMBER 2008		+IT: 450mA -IT: -450mA

NOTE3: Conditions out of those ranges listed in "absolute maximum ratings" may cause permanent damages to the device. In spite of the limits above, functional operation conditions of the device should within the ranges listed in "recommended operating conditions". Exposure to absolute-maximum-rated conditions for prolonged periods may affect device reliability.

NOTE4: The human body model is a 100pF capacitor discharged through a 1.5kΩ resistor into each pin. Test method: MIL-STD-883G Method 3015.

7 ELECTRICAL CHARACTERISTICS

V_{BAT}=3.8V, T_A=25°C for typical values (unless otherwise noted)

PARAMETER		TEST CONDITION	MIN	TYP	MAX	UNIT
V _{BAT}	Power supply	-	3.0		4.5	V
I _{SHUTDOWN}	Current in Shutdown mode	PDN=GND		8	15	μA
I _{STANDBY}	Current in Standby mode	PDN=V _{IO}		130	160	μA
I _{ACTIVE}	Current in Active mode	PDN=V _{IO} , GCR=0x01		0.55	0.8	mA
F _{OSC}	Internal oscillator Frequency accuracy (16MHz)		14.8	16	17.2	MHz
Digital Logical Interface						
V _{IL}	Logic input low level	SDA,SCL,PDN	-0.3		0.45	V
V _{IH}	Logic input high level	SDA,SCL,PDN	0.9			V
I _{IL}	Low level input current	SDA,SCL,PDN		5		nA
I _{IH}	High level input current	SDA,SCL,PDN		5		nA
V _{OL}	Logic output low level	SDA, INTN I _{OUT} =3mA			0.4	V
I _{OL}	Maximum output current	SDA, INTN			10	mA
I _L	Output leakage current	SDA,INTN open drain			1	μA
I²C Interface						
F _{SCL}	I ² C-BUS clock frequency				400	kHz
T _{Deglitch}	SCL deglitch time			200		ns
	SDA deglitch time			250		ns
LED Driver						
I _{MAX}	LED MAX Current	I _{LED} =24.5mA	18.5	24.5	30.5	mA
I _{MATCH}	Matching accuracy	I _{LED} =24.5mA			10	%
V _{DROP}	Drop-out voltage	I _{LED} =24.5mA			300	mV
F _{PWM}	PWM frequency	LCR.FREQ=1	110	122	135	Hz
		LCR.FREQ =0	220	244	270	Hz

NOTE5: the value is tested in default configuration.

8 I²C INTERFACE TIMING

Parameter Name		MIN	TYP	MAX	UNIT
F _{SCL}	Interface Clock frequency			400	kHz
T _{DEGLITCH}	Deglitch time	SCL	200		ns
		SDA	250		ns
T _{HD:STA}	(Repeat-start) Start condition hold time	0.6			μs
T _{LOW}	Low level width of SCL	1.3			μs
T _{HIGH}	High level width of SCL	0.6			μs
T _{SU:STA}	(Repeat-start) Start condition setup time	0.6			μs
T _{HD:DAT}	Data hold time	0			μs
T _{SU:DAT}	Data setup time	0.1			μs
T _R	Rising time of SDA and SCL			0.3	μs
T _F	Falling time of SDA and SCL			0.3	μs
T _{SU:STO}	Stop condition setup time	0.6			μs
T _{BUF}	Time between start and stop condition	1.3			μs

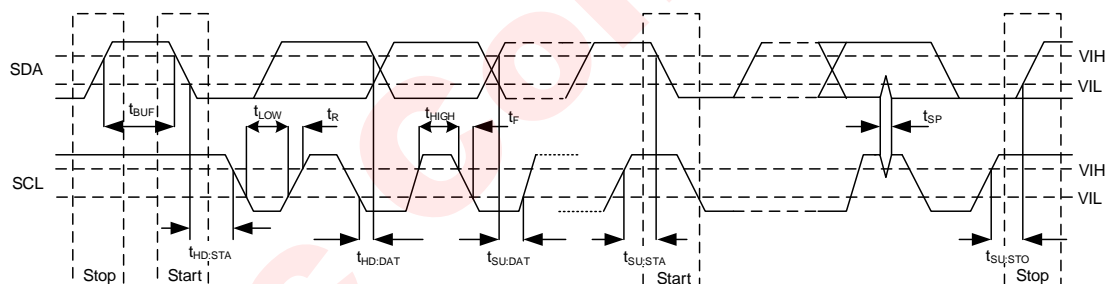

9 FUNCTIONAL DESCRIPTION

9.1 WORK MODE

9.1.1 Power On

After power-up, about 100 μ s delay is required before PDN set to high, otherwise, the device may work incorrectly. The minimal wait time for I²C communication is 5ms, during this period, some internal modules (such as LDO) start to work and reach a stable state.

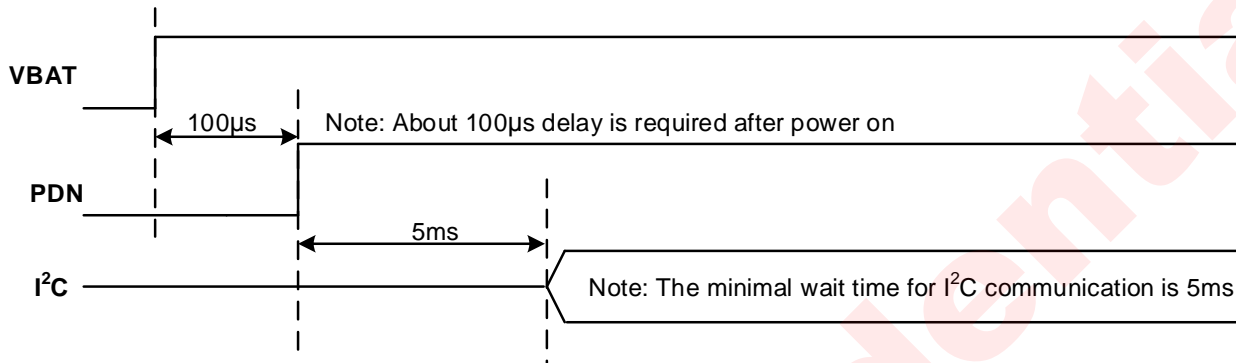

Figure 4 AW9120 Power On

9.1.2 Work Mode

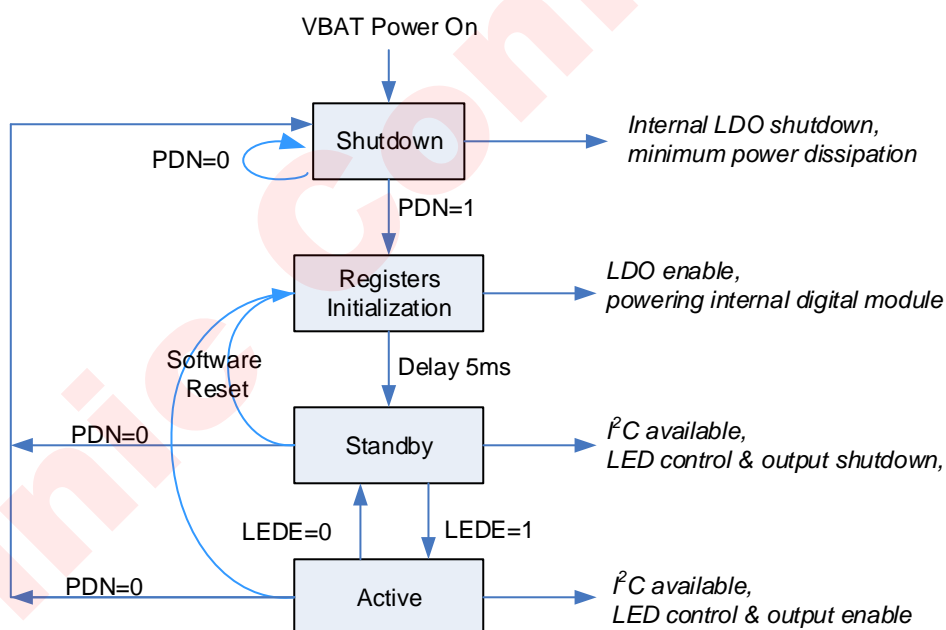

Figure 5 AW9120 Work Mode

After VBAT powered on, if PDN pin is low, the AW9120 is in shut-down mode, the current consumption is less than 15 μ A. When PDN pin becomes high, the internal LDO is activated, and a power-on reset (POR) signal is generated to initialize all internal registers, the device enters standby mode, this is a low power consumption mode, when all circuit functions are disabled. In standby mode, I²C interface is active, all internal configuration register can be written. If control bit GCR.LEDE is written high, the device enters the active mode.

9.2 RESET

9.2.1 Hardware Reset

When PDN pin changes from low to high, the power-up reset (POR) signal is generated, all internal registers are reset.

9.2.2 Software Reset

Writing 0x55AA to register IDRST via I²C interface will activate a software reset to reset all internal registers.

9.3 I²C INTERFACE

AW9120 supports the I²C serial bus and data transmission protocol in fast mode at 400kHz. It operates as a slave on the I²C bus. Connections to the bus are made via the open-drain I/O pins SCL and SDA. The pull-up resistor can be selected in the range of 1k~10kΩ and the typical value is 4.7kΩ. AW9120 can support different high level (1.8V~3.3V) of this I²C interface.

9.3.1 Device Address

The I²C device address (7-bit, followed by the R/W bit(Read=1/Write=0)) of AW9120 is 0x2C/0x2D.

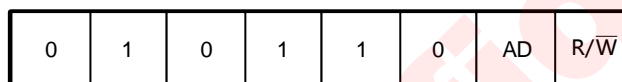

Figure 6 Device Address Configuration

9.3.2 Data Validation

When SCL is high level, SDA level must be constant. SDA can be changed only when SCL is low level.

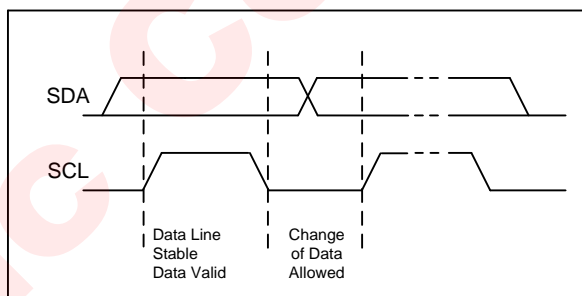

Figure 7 Data Validation Diagram

9.3.3 ACK(Acknowledgement)

ACK means the successful transfer of I²C bus data. After master sends 8bits data, SDA must be released; SDA is pulled to GND by slave device when slave acknowledges.

When master reads, AW9120 sends 8bit data, releases the SDA and waits for ACK from master. If ACK is send and I²C stop is not send by master, AW9120 sends the next data. If ACK is not send by master, AW9120 stops to send data and waits for I²C stop.

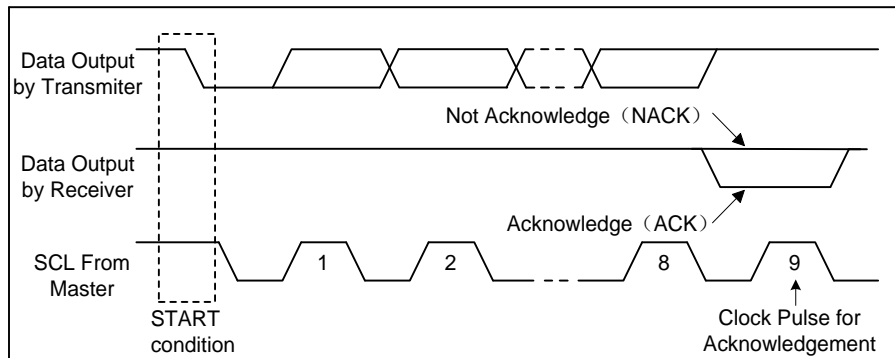

Figure 8 I²C ACK Timing

9.3.4 I²C Start/Stop

I²C start: SDA changes from high level to low level when SCL is high level.

I²C stop: SDA changes from low level to high level when SCL is high level.

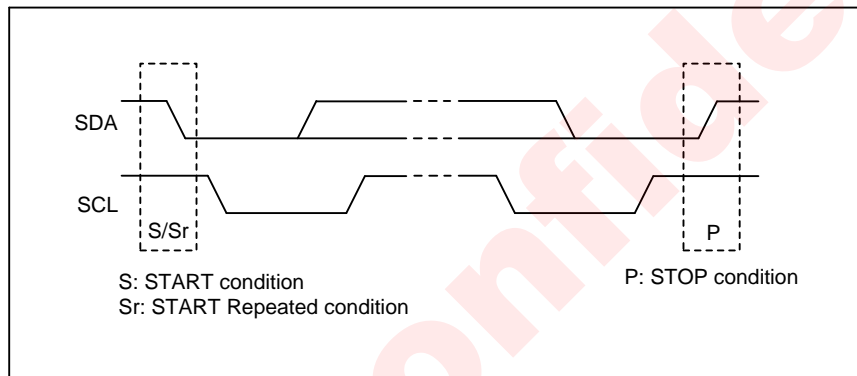

Figure 9 I²C Start/Stop Condition Timing

9.3.5 Write Cycle

One data bit is transferred during each clock pulse. Data is sampled during the high state of the serial clock (SCL). Consequently, throughout the clock's high period, the data should remain stable. Any changes on the SDA line during the high state of the SCL and in the middle of a transaction, aborts the current transaction. New data should be sent during the low SCL state. This protocol permits a single data line to transfer both command/control information and data using the synchronous serial clock.

Each data transaction is composed of a Start Condition, a number of byte transfers (set by the software) and a Stop Condition to terminate the transaction. Every byte written to the SDA bus must be 8 bits long and is transferred with the most significant bit first. After each byte, an Acknowledge signal must follow.

In a write process, the following steps should be followed:

- Master device generates START condition. The "START" signal is generated by lowering the SDA signal while the SCL signal is high.
- Master device sends slave address (7-bit) and the data direction bit (R/W = 0).
- Slave device sends acknowledge signal if the slave address is correct.
- Master sends control register address (8-bit)
- Slave sends acknowledge signal
- Master sends data high 8Bit to be written to the addressed register
- Slave sends acknowledge signal

- h) Master sends data low 8Bit to be written to the addressed register
- i) Slave sends acknowledge signal
- j) Master generates STOP condition to indicate write cycle end

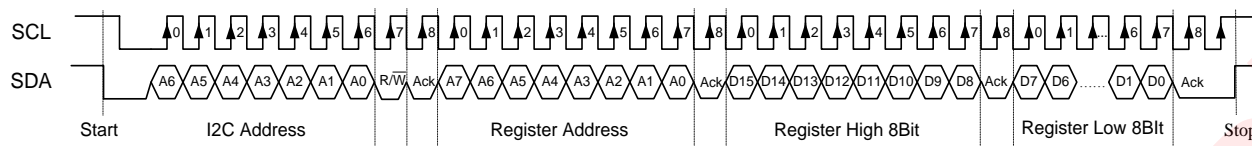

Figure 10 AW9120 I2C Write Timing

9.3.6 Read Cycle

In a read cycle, the following steps should be followed:

- a) Master device generates START condition
- b) Master device sends slave address (7-bit) and the data direction bit (R/W = 0).
- c) Slave device sends acknowledge signal if the slave address is correct.
- d) Master sends control register address (8-bit)
- e) Slave sends acknowledge signal
- f) Master generates STOP condition followed with START condition or REPEAT START condition
- g) Master device sends slave address (7-bit) and the data direction bit (R/W = 1).
- h) Slave device sends acknowledge signal if the slave address is correct.
- i) Slave sends data high 8Bit from addressed register.
- j) Master sends acknowledge signal
- k) Slave sends data low 8Bit from addressed register.
- l) If the master device sends acknowledge signal, the slave device will increase the control register address by one, then send the next data from the new addressed register. If master sends no acknowledge signal, the slave device stop to send data and wait for STOP condition.
- m) If the master device generates STOP condition, the read cycle is ended.

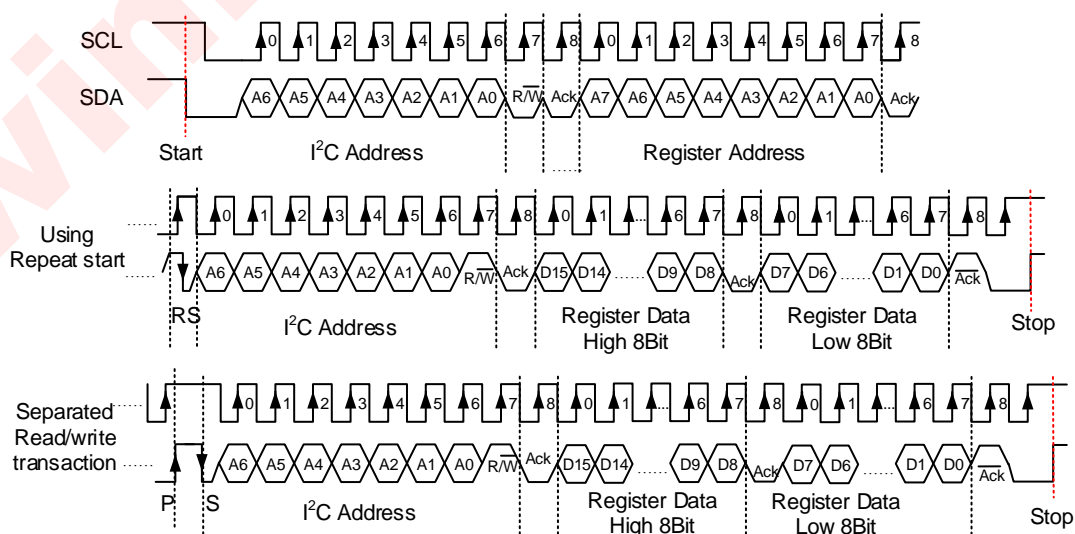

Figure 11 AW9120 I2C Read Timing

9.4 OSCILLATOR

An internal oscillator provides clock for both capacitive touch detecting and LED controlling circuit. If register bit GCR.LEDE is high, the OSC starts to work, the start-up time is about 5 μ s. When the register bit GCR.LEDE are low, the internal OSC stops.

9.5 LED DRIVER

LED driver provide 20 current sources to drive LEDs, a dedicated Application-Specific-Processor (ASP) is designed to produce versatile lighting effect for mobile devices.

If the control bit GCR.LEDE is 0, LED driver circuit is in reset state, all 20 LED outputs are disabled. If control bit GCR.LEDE is 1, the LED driver circuit is enabled, the control bit LER.LENx (x=1 to 20) configure the corresponding LED channel is active or not.

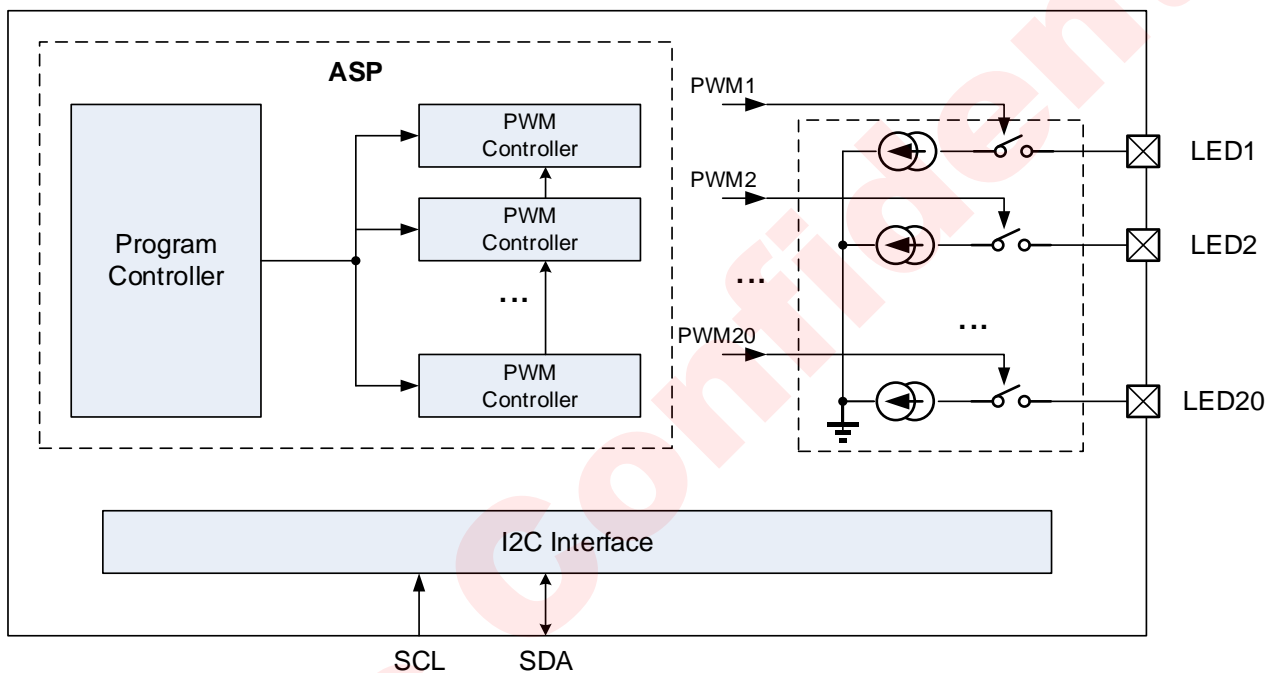

Figure 12 AW9120 LED Dimming Control Module Diagram

9.5.1 LED brightness controller

Pulse Width Modulation (PWM) is used to adjust the brightness of LED, 256 level brightness with 9bit resolution is adapted. The PWM frequency can be configured between 122Hz or 245Hz by control bit LCR.FREQ.

The ASP generates the PWM signal with dedicated and highly efficient dimming control instruction for all 20 independent LED constant current source. By programming, user-defined complicated lighting effect could be produced.

The LED control instruction executed by ASP could come from LED SRAM or external I²C register. The register CTRS can choose every LED channel to be controlled by SRAM program or by I²C register.

- CTRS[n] = 0, LED n controller is controlled by the internal SRAM instruction;
- CTRS[n] = 1, LED n controller is controlled by the external I²C register.

9.5.2 LED Constant current driver

For each LED, the maximum output constant current is 24.5mA, with 8 level adjustable by register IMAXn (n=1~20).

9.5.3 ASP

ASP module is consist of one program controller and 20 PWM controllers.

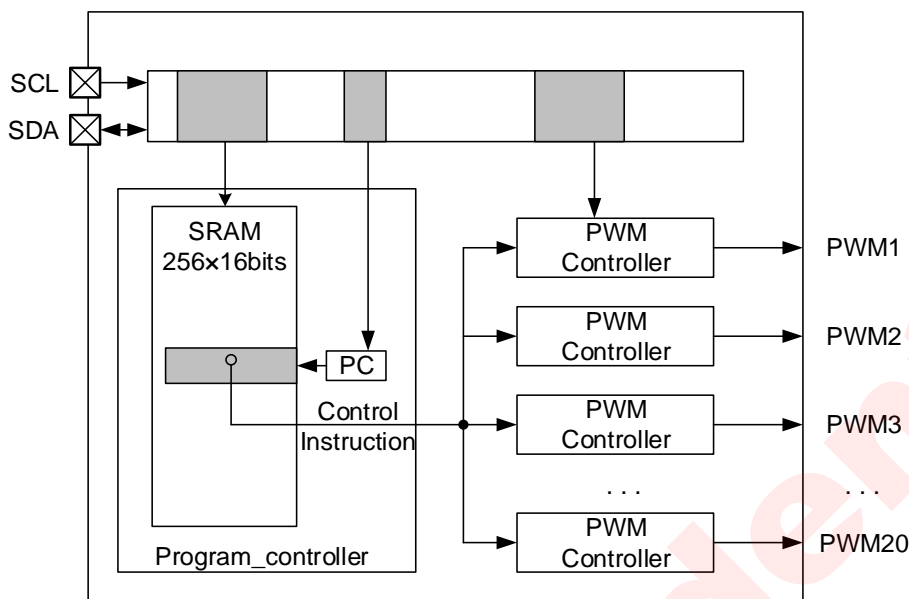

Figure 13 ASP Structure Diagram

9.5.3.1 Program Controller

The program controller is clocked by 32kHz internal clock, each instruction is executed in one clock cycle. The program controller is consist of a program SRAM, an algorithmic logic unit (ALU) and other internal registers. The 256x16bit internal SRAM is used to store LED lighting effect program loaded through I²C interface, the I²C interface also can start or stop the program execution. There are 4 internal registers RA/RB/RC/RD participating ALU operation so as to generate complicated program control such as repeating and looping. Except for that, there are 8 8bit temporary data registers(R1~R8) and 5 special function registers. Their internal address and function description is shown in the table below.

Table 1 Address allocation of internal data register in ASP

Register	Address(HEX)	Description
R1	00	R1 data temporary register, 8bit, I ² C readable
R2	01	R2 data temporary register, 8bit, I ² C readable
R3	02	R3 data temporary register, 8bit, I ² C readable
R4	03	R4 data temporary register, 8bit, I ² C readable
R5	04	R5 data temporary register, 8bit, I ² C readable
R6	05	R6 data temporary register, 8bit, I ² C readable
R7	06	R7 data temporary register, 8bit, I ² C readable
R8	07	R8 data temporary register, 8bit, I ² C reading
GMSK1	0d	Global control mask register(M8~M1)
GMSK2	0e	Global control mask register(M12~M9)
GMSK3	0f	Global control mask register(M20~M13)

Table 2 Special function registers definition

Register	B7	B6	B5	B4	B3	B2	B1	B0	Description
GMSK1	M8	M7	M6	M5	M4	M3	M2	M1	Mask control for global control

GMSK2					M12	M11	M10	M9	instruction. When Mn=1, LEDn will not be affected by global control instruction.
GMSK3	M20	M19	M18	M17	M16	M15	M16	M13	

9.5.3.2 PWM Controller

The PWM controller is execution unit of LED control instruction. There are 20 PWM controllers receiving the LED effect instruction from SRAM, and generate 8bit PWM code, which will be convert to 9bit duty cycle control code by logarithmic I transformation. If LCR.LOGLN=00, the transformation is natural logarithm(\log_e). If LCR.LOGLN=01, the transformation is logarithm of 10 (\log_{10}), otherwise the 8b-to-9b transformation of PWM code is linear.

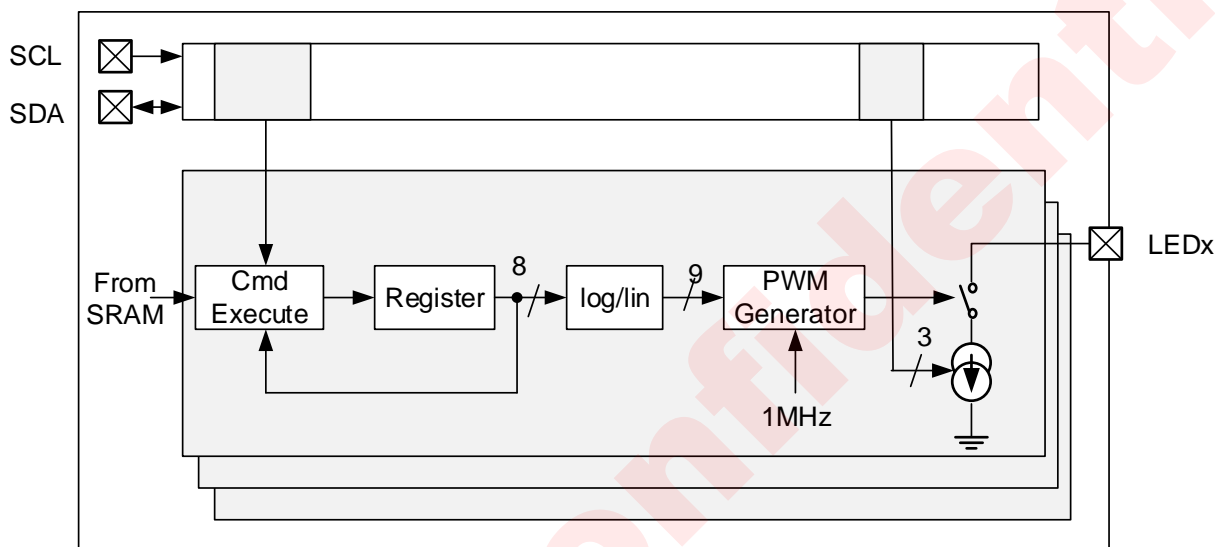

Figure 14 PWM Controller Schematic Diagram

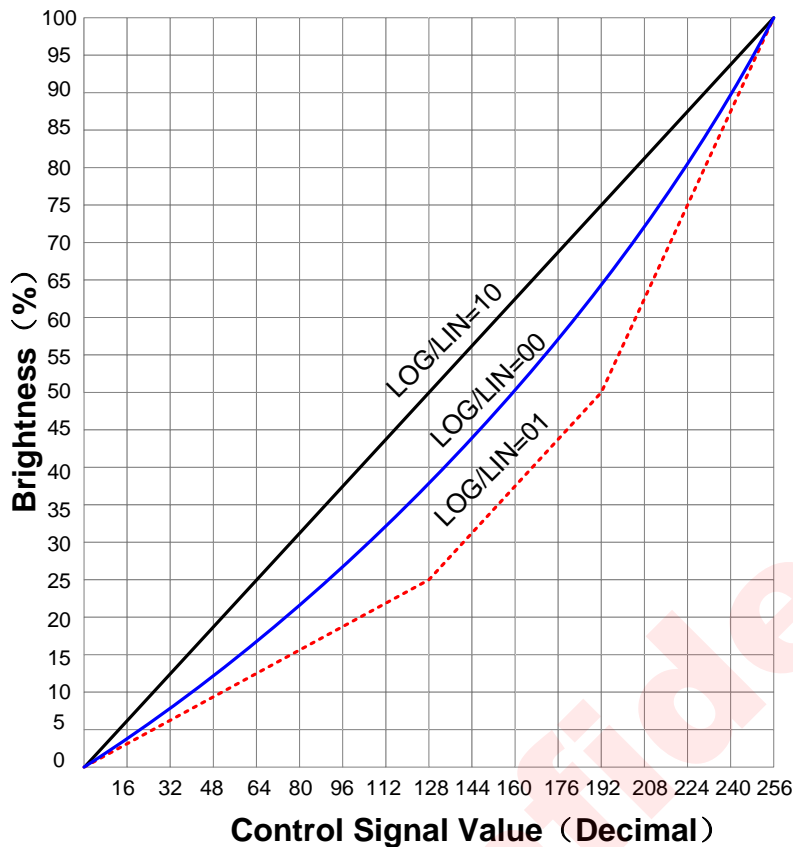

Figure 15 8bit-to-9bit PWM code transformation curve

9.5.3.3 Program Loading and execution

a) Program loading

It is recommended to load SRAM program only when control bit PMD.PROGMMD is 00. In this state, the internal program can be read/write through I²C interface. When loading program, please write the SRAM loading address in register WADDR(0x7E) at first, and then write the 16bit LED effect instruction to register WDATA(0x7F). Continuously loading program is supported, after a 16b instruction is written through register WDATA, the value of WADDR will automatically plus by 1.

b) Program execution

Register bit PMD.PROGMMD[1:0] controls the loading and execution mode of SRAM program.

When register bit IPMD.PROGMMD[1:0]=00, program execution is shut down, SRAM program and program pointer(PC) are permitted to be loaded.

When IPMD.PROGMMD[1:0] is written to be 01 from another value, current program will stop, and PC will be reload by register SADDR, and then executes the SRAM program starting from the address of PC

When Register bit PMD.PROGMMD[1:0] =10, the SRAM program will be executed by the mode defined by register bit RMD.RUNMD[1:0]

Table 3 Program running mode control register

RMD.RUNMD	Function Description
0 0	Hold mode. Program stop and PC hold after one instruction is finished.

0 1	Single step mode, only used for debugging. Once writing 01 to RUNMD, only one instruction will be executed with PC+1, and then RMD.RUNMD is cleared (return to hold mode)
1 0	Continuously running mode, program starts from the address of PC.
1 1	Repeating mode, only used for debugging. Once writing 11 to RUNMD, current instruction will be executed without PC+1, and then RMD.RUNMD is cleared (return to hold mode)

9.5.3.4 SRAM program Instruction

There are 27 commands in ASP instruction set, including LED control command, data operation and transfer command, wait and branch control command. The Rx,Ry and Rz in instruction list means the internal register RA, RB, RC and RD, each of them can participate the ALU operation as source or destination register.

Table 4 LED Effect Instruction

Command	15	14	13	12	11	10	9	8	7	6	5	4	3	2	1	0
JP	0	0	0	0	0	0	0	0	ADDR[7:0]							
NOP	0	0	0	0	0	0	0	1	-	-	-	-	-	-	-	-
----	0	0	0	0	0	0	1	X								
JPZ Addr	0	0	0	0	0	1	0	0	ADDR[7:0]							
JPNZ Addr	0	0	0	0	0	1	0	1	ADDR[7:0]							
JPS Addr	0	0	0	0	0	1	1	0	ADDR[7:0]							
JPNS Addr	0	0	0	0	0	1	1	1	ADDR[7:0]							
LD Rz Im	0	0	0	0	1	0	Rz		Im[7:0]							
CMPI Rz Im	0	0	0	0	1	1	Rz		Im[7:0]							
ANDR Rz Im	0	0	0	1	0	0	Rz		Im[7:0]							
ORR Rz Im	0	0	0	1	0	1	Rz		Im[7:0]							
RDR Rz Addr	0	0	0	1	1	0	Rz		ADDR[7:0]							
WDR Rz Addr	0	0	0	1	1	1	Rz		ADDR[7:0]							
ADDI Rz Im	0	0	1	0	0	0	Rz		Im[7:0]							
AUBI Rz Im	0	0	1	0	0	1	Rz		Im[7:0]							
ADDR Rx Ry	0	0	1	0	1	0	Rz		-	-	-	-	Rx		Ry	
SUBR Rx Ry	0	0	1	0	1	1	Rz		-	-	-	-	Rx		Ry	
CMPR Rx Ry	0	0	1	1	0	0	0	0	-	-	-	-	Rx		Ry	
----	0	0	1	1	0	0	X	X								
END Int Rst	0	0	1	1	0	1	0	0	-	-	-	-	-	-	Int	Rst
INTN_MASKOFF	0	0	1	1	0	1	1	0	-	-	-	-	-	-	-	-
INTN_MASKON	0	0	1	1	0	1	1	1	-	-	-	-	-	-	-	-
WAITI Pre Time	0	0	1	1	1	Pre	T[9:0]									
SETPWMR Rx Ry	0	1	0	0	0	0	0	-	-	0	0	0	Rx		Ry	
RAMPR Dir Rx Ry	0	1	0	0	0	0	1	Dir	-	0	0	0	Rx		Ry	
SETSTEPTMRR Pre Rx Ry	0	1	0	0	0	1	0	-	Pre	0	0	0	Rx		Ry	

SETSTEPTMRI Pre Ch Im	1	0	0	Ch[4:0]	Pre	-	Im[5:0]
SETPWMI Ch Im	1	0	1	Ch[4:0]			Im[7:0]
RAMPI Dir Ch Im	1	1	Dir	Ch[4:0]			Im[7:0]

a) Special LED Control Command

There are 3 types of LED control command.

- **SETPWM:** set the brightness level (0~255)for specified LED channel;
- **RAMP:** set the specified LED channel fade in or fade out for expected step(0~255)
- **SETSTEP:** set the fading slope for specified LED channel;

All control parameter in above commands can either come from specified register (RA~RD), or from immediate data contained in command..

All LED control command supports broadcast mode, one instruction may send to multiple or all LEDs

When SRAM program running, if Ch field or value of Rx in LED control command is '11111', the current command is active for all LED with setting of CTRSR.bitn=0. If Ch field or value of Rx in LED control command is '11110', the current command is only active for those channel with setting of GMSKx=0.

When LED instruction is come from I²C interface directly, it is recommended to use only the command with immediate data. If the Ch field in command is "11111", the current command is only active for those LED with STRSR.bitn=1..

Table 5 LED Control Instruction explanation

Instruction	Description
Register Parameter	
SETPWMR Rx Ry	Set the PWM brightness level with parameter in register Rx: LED channel number, 0~19 for LED 1~ LED 20 respectively Ry: Brightness level, 0~255
RAMPR Dir Rx Ry	Set the Fade-in/Fade-out for specified step with parameter in register Dir: 1: Fade-in; 0: Fade-out Rx: LED channel number, 0~19 for LED 1~ LED 20 respectively Ry: the step number of Fade-in/Fade-out
SETSTEPTMRR Pre Rx Ry	Set the RAMP slope with parameter in register Pre: basic time unit, 0: 0.5ms; 1: 16ms Rx: LED channel number, 0~19 for LED 1~ LED 20 respectively Ry: RAMP step time = (Ry+1)*Pre
Immediate Data	
SETPWMI Ch Im	Set the PWM brightness level with immediate parameter Ch: LED channel number, 0~19 for LED 1~ LED 20 respectively Im: Brightness level, 0~255
RAMPI Dir Ch Im	Set the Fade-in/Fade-out for specified steps with immediate parameter Dir: 1: Fade-in; 0: Fade-out Ch: LED channel number, 0~19 for LED 1~ LED 20 respectively Im: the steps of Fade-in/Fade-out
SETSTEPTMRI Pre Ch Im	Set the RAMP step time with immediate parameter Pre: basic unit of time, 0: 0.5ms; 1: 16ms Ch: LED channel number, 0~19 for LED 1~ LED 20 respectively Im: RAMP step time = (Im +1)*Pre, 0~63

Table 6 Program Control and operation Instruction

Instruction	Encoding	Description
branch Instruction		
JP Addr	0x00xx	Immediate Jump, jump to PC = Addr
JPZ Addr	0x04xx	Conditional Jump, If Rz is 0, jump to PC = Addr
JPNZ Addr	0x05xx	Conditional Jump, If Rz is not 0, jump to PC = Addr
JPS Addr	0x06xx	Conditional Jump, If Rz < 0, jump to PC = Addr
JPNS Addr	0x07xx	Conditional Jump, If Rz >= 0, jump to PC = Addr
Data Transfer Instruction		
LD Rz Im	0x08xx - 0x0bxx	Rz = Im
RDR Rz Addr	0x18xx - 0x1bxx	Rz = *Addr
WDR Rz Addr	0x1cxx - 0x1fxx	*Addr = Rz
Computation Instruction		
CMPI Rz Im	0x0cxx - 0x0fxx	Rz – Im, only change S/Z flag
CMPR Rx Ry	0x30xx	Rx – Ry, only change S/Z flag
ANDR Rz Im	0x10xx - 0x13xx	Rz = Rz & Im, affect S/Z flag
ORR Rz Im	0x14xx - 0x17xx	Rz = Rz Im, affect S/Z flag
ADDI Rz Im	0x20xx - 0x23xx	Rz = Rz + Im, affect S/Z flag
SUBI Rz Im	0x24xx - 0x27xx	Rz = Rz – Im, affect S/Z flag
ADDR Rz Rx Ry	0x28xx - 0x2bxx	Rz = Rz + Ry, affect S/Z flag
SUBR Rz Rx Ry	0x28xx - 0x2bxx	Rz = Rz – Ry, affect S/Z flag
Control Instruction		
END Int Rst	0x34xx	Program end with optionally reset register RMD and generate interrupt

		Int= 0: no interrupt after instruction executed; Int= 1: generate interrupt after instruction executed Rst=0: PC add 1 after instruction executed; Rst=1: Reload PC with SADDR after instruction executed
INTN_MASKOFF	0x36xx	Unmask internal interrupt
INTN_MASKON	0x37xx	Mask internal interrupt
WAITI Pre Time	0x38xx - 0x3fxx	Wait for specified time Pre: time of basic waiting cycle, 0: 0.5ms; 1: 16ms Time: number of waiting cycle, max value is 1023, wait time=Pre*Time

9.5.3.5 Example

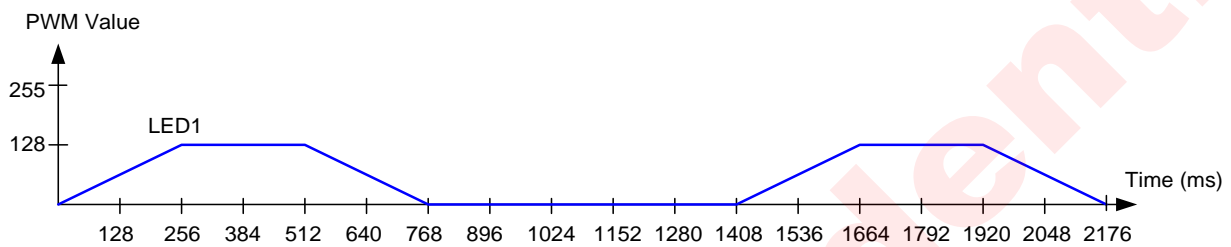

Figure 16 LED Effect Programming Diagram

Table 7 Reference Instruction of LED Effect Programming

PC	Assemble Instruction	Machine Code	explanation
0	SETSTEPTMRI 0x00 0x1F 0x03	0x9F03	RAMPI step time: 2ms
1	SETPWMI 0x1F 0x00	0xBF00	ALL LED turn off
	START:		Address Label "START" (02H)
2	RAMPI 0x01 0x00 0x80	0xE080	LED1 fade in, 128 steps breath
3	WAITI 0x01 0x20	0x3C20	Wait 512ms
4	RAMPI 0x00 0x00 0x80	0xC080	LED1 fade out, 128 steps breath
5	WAITI 0x01 0x38	0x3C38	Wait 896ms
6	JP START	0x0002	Jump to START, PC=2

Step1: Power On, configure register

- VBAT power on, 4.2V
- Pull PDN to 3V
- Wait 5ms
- GCR = 0x0001 // enable LED module
- LER = 0x0001 // enable LED1
- IMAX1 = 0x0001 // IMAX = 3.5mA
- PMD.PROGRMD = 00 //hold mode
- RMD.RUNMD = 00 //hold mode

Step2: Load Instruction to SRAM

- WADDR = 0x0000 // load program starting at address =0x0000
- WDATA = 0x9F03
- WDATA = 0xBF00
- WDATA = 0xE080
- WDATA = 0x3C20

- WDATA = 0xC080
- WDATA = 0x3C38
- WDATA = 0x0002

Step3: Run

- SADDR = 0x0000
- RMD.RUNMD = 10 // execution mode change to run mode,
- PMD.PROGMD = 01 // start program from 0x0000

awinic Confidential

10 REGISTER DESCRIPTION

10.1 REGISTER CONFIGURATION

Address	Register	15	14	13	12	11	10	9	8	7	6	5	4	3	2	1	0
0x00	IDRST	D15	D14	D13	D12	D11	D10	D9	D8	D7	D6	D5	D4	D3	D2	D1	D0
0x01	GCR	0	0	0	0	0	0	0	0	0	0	0	0	0	0	0	LEDE
0x02~0x4F	-	0	0	0	0	0	0	0	0	0	0	0	0	0	0	0	-
0x50	LER1	0	0	0	0	LE12	LE11	LE10	LE9	LE8	LE7	LE6	LE5	LE4	LE3	LE2	LE1
0x51	LER2	0	0	0	0	0	0	0	0	LE20	LE19	LE18	LE17	LE16	LE15	LE14	LE13
0x52	LCR	0	0	0	0	0	0	0	SRMINI	LIRMD		-		LIE	FREQ	LOG/LIN	
0x53	PROGMD	0	0	0	0	0	0	0	0	0	0	0	0	0	0	PROGMD	
0x54	RUNMD	0	0	0	0	0	0	0	0	0	0	0	0	0	0	RUNMOD	
0x55	CTRS1	0	0	0	0	CS12	CS11	CS10	CS9	CS8	CS7	CS6	CS5	CS4	CS3	CS2	CS1
0x56	CTRS2	0	0	0	0	0	0	0	0	CS20	CS19	CS18	CS17	CS16	CS15	CS14	CS13
0x57	IMAX1	0	IMAX4			0	IMAX3			0	IMAX2			0	IMAX1		
0x58	IMAX2	0	IMAX8			0	IMAX7			0	IMAX6			0	IMAX5		
0x59	IMAX3	0	IMAX12			0	IMAX11			0	IMAX10			0	IMAX9		
0x5A	IMAX4	0	IMAX16			0	IMAX15			0	IMAX14			0	IMAX13		
0x5B	IMAX5	0	IMAX20			0	IMAX19			0	IMAX18			0	IMAX17		
0x5C~0x5D	-	0	0	0	0	0	0	0	0	0	0	0	0	0	0	0	0
0x5E	ISR2	0	0	0	0	0	0	0	0	0	0	0	0	0	0	0	LIS
0x5F	SADDR	0	0	0	0	0	0	0	0	SADDR							
0x60	PCR	0	0	0	0	0	0	0	0	PC							
0x61	CMDR	D15	D14	D13	D12	D11	D10	D9	D8	D7	D6	D5	D4	D3	D2	D1	D0
0x62	RA	0	0	0	0	0	0	0	0	RA							
0x63	RB	0	0	0	0	0	0	0	0	RB							
0x64	RC	0	0	0	0	0	0	0	0	RC							
0x65	RD	0	0	0	0	0	0	0	0	RD							
0x66 ~ 0x6D	R1 ~ R8	0								R1 ~ R8							
6E	GRPR	0	0	0	0	0	GS9	GS8	GS7	GS6	GS5	GS4	GS3	GS2	GS1	D1	D0
7D	WP	WPW								0	0	0	0	0	0	0	0
7E	WADDR	0	0	0	0	0	0	0	0	ADDR							
7F	WDATA	CODE															

10.2 GLOBAL REGISTER DESCRIPTION

10.2.1 IDRST, Chip ID and Software Reset

Address: 0x00, R/W															
15	14	13	12	11	10	9	8	7	6	5	4	3	2	1	0
D15	D14	D13	D12	D11	D10	D9	D8	D7	D6	D5	D4	D3	D2	D1	D0
Bit	Symbol		Description												
15:0	IDRST		Chip ID: 0xB223 Software reset: write 0x55AA to IDRST, reset the whole device.												

10.2.2 GCR, Global Control Register

Address: 0x01, R/W, default: 0x0000															
15	14	13	12	11	10	9	8	7	6	5	4	3	2	1	0
0	0	0	0	0	0	0	0	0	0	0	0	0	0	0	0
Bit	Symbol		Description												
0	LEDE		LED driver function 0: disable LED driver (default) 1: enable LED driver												

10.3 LED Effect Control Register

10.3.1 LER1, LED Driver Enable Register

Address: 0x50, R/W, default: 0x0000															
15	14	13	12	11	10	9	8	7	6	5	4	3	2	1	0
0	0	0	0	LE12	LE11	LE10	LE9	LE8	LE7	LE6	LE5	LE4	LE3	LE2	LE1
Bit	Symbol		Description												
11:0	Lex		LED output enable 0: disable 1: enable												
15:12	-		Reserved, must be 0												

10.3.2 LER2, LED Driver Enable Register

Address: 0x51, R/W, default: 0x0000																
15	14	13	12	11	10	9	8	7	6	5	4	3	2	1	0	
0	0	0	0	0	0	0	0	0	LE20	LE19	LE18	LE17	LE16	LE15	LE14	LE13
Bit	Symbol		Description													
7:0	Lex		LED output enable 0: disable 1: enable													
15:8	-		Reserved, must be 0													

10.3.3 LCR, LED Effect Configuration Register

Address: 0x52, R/W, default: 0x0080															
15	14	13	12	11	10	9	8	7	6	5	4	3	2	1	0
0	0	0	0	0	0	0	SRMINI	LIRMD	-	-	-	LIE	FREQ	LOGLIN	-
Bit	Symbol		Description												
1:0	Log/Lin		Log/Linear dimming mode selection 00: log dimming 1, logI (default) 01: log dimming 2, log10 1x: linear dimming												
2	FREQ		PWM frequency selection 0: 245Hz (default) 1: 122Hz												
3	LIE		LED program end interrupt enable 0: disable interrupt (default) 1: enable interrupt												
5:4	-		-												

7:6	LIRMD	LED effect code run mode after responding to interrupt request 00: hold mode, PC point can be changed, program hold and wait for RMD.RUNMD 01: step mode 10: run mode (default)
8	SRMINI	SRAM reset bit, write 1, reset SRAM; read SRAM status, default is 0.

10.3.4 PMD, Program Mode Register

Address: 0x53, R/W, default: 0x0000															
15	14	13	12	11	10	9	8	7	6	5	4	3	2	1	0
0	0	0	0	0	0	0	0	0	0	0	0	0	0	0	PROGMD
Bit	Symbol		Description												
1:0	PROGMD		Program control mode 00: load program via I ² C interface (default) 01: re-load program and execute. When write 01 to PROGMD[1:0], set PC pointer will be updated with SADDR, then start to run program, and finally PROGMD[1:0] is changed to 10 automatically 10: run program. Under this mode, the control bit RUNMD in register RMD can configure different program running mode for normal operation or debug. 11: undefined												

10.3.5 RMD, Program Run Mode Register

Address: 0x54, R/W, default: 0x0000															
15	14	13	12	11	10	9	8	7	6	5	4	3	2	1	0
0	0	0	0	0	0	0	0	0	0	0	0	0	0	0	RUNMD
Bit	Symbol		Description												
1:0	RUNMD		SRAM program run mode, only active for these LED set with CTRSR.CSx=0 00: hold mode, program stop and hold PC pointer (default) 01: step mode, RUNMD reset, PC+1 after the current program executed 10: run mode, normal program run 11: repeat mode, RUNMD reset, PC hold after the current program executed												

10.3.6 CTRSR1, LED Control Source Selection Register

Address: 0x55, R/W, default: 0x0000															
15	14	13	12	11	10	9	8	7	6	5	4	3	2	1	0
0	0	0	0	CS12	CS11	CS10	CS9	CS8	CS7	CS6	CS5	CS4	CS3	CS2	CS1
Bit	Symbol		Description												
11:0	CSx		LED control source 0: LEDx controlled by SRAM program 1: LEDx controlled by external MCU via I ² C interface												

10.3.7 CTRSR2, LED Control Source Selection Register

Address: 0x56, R/W, default: 0x0000															
15	14	13	12	11	10	9	8	7	6	5	4	3	2	1	0
0	0	0	0	0	0	0	0	CS20	CS19	CS18	CS17	CS16	CS15	CS14	CS13
Bit	Symbol		Description												
7:0	CSx		LED control source 0: LEDx controlled by SRAM program 1: LEDx controlled by external MCU via I ² C interface												

10.3.8 IMAX1~IMAX20, LEDx Maximum Output Current Register

Address: 0x57~0x5B, R/W, default: 0x0000															
15	14	13	12	11	10	9	8	7	6	5	4	3	2	1	0
0	IMAX4			0	IMAX3			0	IMAX2			0	IMAX1		
0	IMAX8			0	IMAX7			0	IMAX6			0	IMAX5		
0	IMAX12			0	IMAX11			0	IMAX10			0	IMAX9		
0	IMAX16			0	IMAX15			0	IMAX14			0	IMAX13		
0	IMAX20			0	IMAX19			0	IMAX18			0	IMAX17		

Bit	Symbol	Description
14:12 10:8 6:4 2:0	IMAXx	LEDx maximum output current selection 000: 0mA (default) 001: 3.5mA 010: 7.0mA 011: 10.5mA 100: 14.0mA 101: 17.5mA 110: 21.0mA 111: 24.5mA

10.3.9 LISR, LED Interrupt Status Register

Address: 0x5E, R(clear by reading), default: 0x0000															
15	14	13	12	11	10	9	8	7	6	5	4	3	2	1	0
0	0	0	0	0	0	0	0	0	0	0	0	0	0	0	LIS
Bit	Symbol	Description													
1	LIS	LED program end interrupt status, set by END instruction with parameter int=1, used for inform external MCU that program has finished. LCR.LIE is the enable bit for LIS. 0: no interrupt 1: interrupt request													

10.3.10 SADDR, Program Start Address Register

Address: 0x5F, R/W, default: 0x0000															
15	14	13	12	11	10	9	8	7	6	5	4	3	2	1	0
0	0	0	0	0	0	0	0	0	0	0	SADDR				
Bit	Symbol	Description													
7:0	SADDR	SRAM program starting address. For reload and run mode, if setting PMD.PROGMD=10, program will jump to PC=SADDR and run again.													

10.3.11 PCR, LED Program Control Pointer Register

Address: 0x60, R/W, default: 0x0000															
15	14	13	12	11	10	9	8	7	6	5	4	3	2	1	0
0	0	0	0	0	0	0	0	PC							
Bit	Symbol	Description													
7:0	PC	SRAM program pointer(PC), can be written by I ² C interface. For normal program execution, set the PC pointer at PMD.PROGMD= 00 mode at first, and then write PMD.PROGMD with 10.													

10.3.12 CMDR, LED Command Register

Address: 0x61, R/W, default: 0x0000															
15	14	13	12	11	10	9	8	7	6	5	4	3	2	1	0
CMD															
Bit	Symbol	Description													
15:0	CMD	External controlled command. Used to send external LED command which is only active for those LED configured with control bit CTRSR.CSx=1. The external controlled command adapted the same instruction with internal ASP.													

10.3.13 RA/RB/RC/RD, LED Internal Program Register

Address: 0x62~0x65, R, default: 0x0000															
15	14	13	12	11	10	9	8	7	6	5	4	3	2	1	0
0	0	0	0	0	0	0	0	RA							
0	0	0	0	0	0	0	0	RB							
0	0	0	0	0	0	0	0	RC							
0	0	0	0	0	0	0	0	RD							
Bit	Symbol	Description													
7:0	RA/RB/RC/RD	LED internal program register, read only, for debug usage.													

10.3.14 R1~R8, LED Internal Data Register

Address: 0x66~0x6D, R, default: 0x0000															
15	14	13	12	11	10	9	8	7	6	5	4	3	2	1	0
0	0	0	0	0	0	0	0								R1
0	0	0	0	0	0	0	0								R2
0	0	0	0	0	0	0	0								R3
0	0	0	0	0	0	0	0								R4
0	0	0	0	0	0	0	0								R5
0	0	0	0	0	0	0	0								R6
0	0	0	0	0	0	0	0								R7
0	0	0	0	0	0	0	0								R8
Bit	Symbol	Description													
7:0	R1~R8	LED internal data register, for debug usage.													

10.3.15 GRP, LED Group Operation Register

Address: 0x6E, R, default: 0x0000															
15	14	13	12	11	10	9	8	7	6	5	4	3	2	1	0
0	0	0	0	0	GS9	GS8	GS7	GS6	GS5	GS4	GS3	GS2	GS1		
Bit	Symbol	Description													
10:2	GS[8:0]	LED channel selection for external group control command. GS[n]=0, LED _n is not included in external LED command with chan=0x1E; GS[n]=1, LED _n is included in external LED command with chan=0x1E;													

10.3.16 WADDR, LED Program Loading Address Register

Address: 0x7E, R/W, default: 0x0000															
15	14	13	12	11	10	9	8	7	6	5	4	3	2	1	0
0	0	0	0	0	0	0	0								ADDR
Bit	Symbol	Description													
7:0	ADDR	SRAM address for program access via I ² C interface													

10.3.17 WDATA, LED Program Loading Data Register

Address: 0x7F, R/W, default: 0x0000															
15	14	13	12	11	10	9	8	7	6	5	4	3	2	1	0
CODE															
Bit	Symbol	Description													
15:0	CODE	SARM data for program access via I ² C interface													

10.3.18 WPR, Writing Protection Register

Address: 0x7D, R/W, default: 0x5500															
15	14	13	12	11	10	9	8	7	6	5	4	3	2	1	0
WPW									0	0	0	0	0	0	0
Bit	Symbol	Description													
15:8	WPW	Writing protection control, If WPW=0x55, all register is writable, otherwise all register except for WPR is not allowed to be written.													

11 TAPE AND REEL INFORMATION

11.1 Carrier Tape (All dimensions are in millimeters)

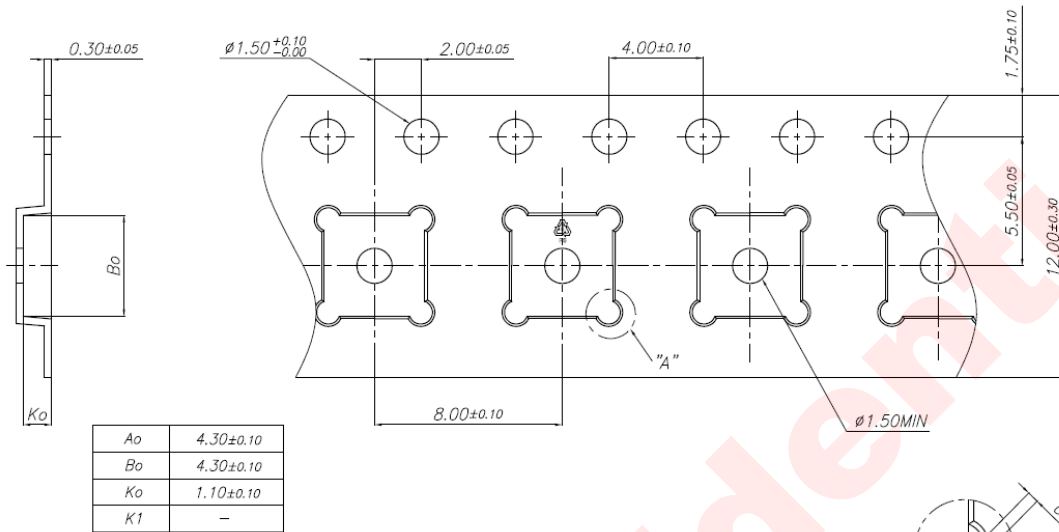

NOTES:

1. 10 sprocket hole pitch cumulative tolerance 0.2/-0.2
2. Camber not to exceed 1mm in 250mm
3. Material: Black conductive Polystyrene
4. Ao and Bo measured on a plane 0.3mm above the bottom of the pocket
5. Ko measured from a plane on the inside bottom of the pocket to the top surface of the carrier.
6. Pocket center position relative to sprocket hole center measured as true position center of pocket, not pocket hole center.
7. Pocket center and pocket hole center must be same position.



P/N: 433062

A SCALE
(2/1)

UNLESS OTHERWISE SPECIFIED: DIMENSIONS ARE IN MILLIMETERS TOLERANCE		THIRD ANGLE PROJECTION		Kostat, Inc.	
DECIMALS	ANGULAR	DESIGN	TITLE		REV. NO.
0.1	± 1°	M.H.KANG	CARRIER TAPE		00
0.01		CHECK	SIZE	DWG. NO.	
0.005			A4	KS-1208-176	
DO NOT SCALE DRAWING		APPROVED	SCALE	RELEASE DATE	SHEET
			5/1	MAR.26.2004	1 of 1

11.2 PIN1 Direction

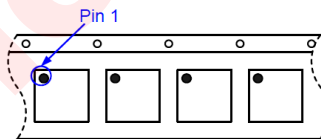

User Direction of Feed

11.3 Reel

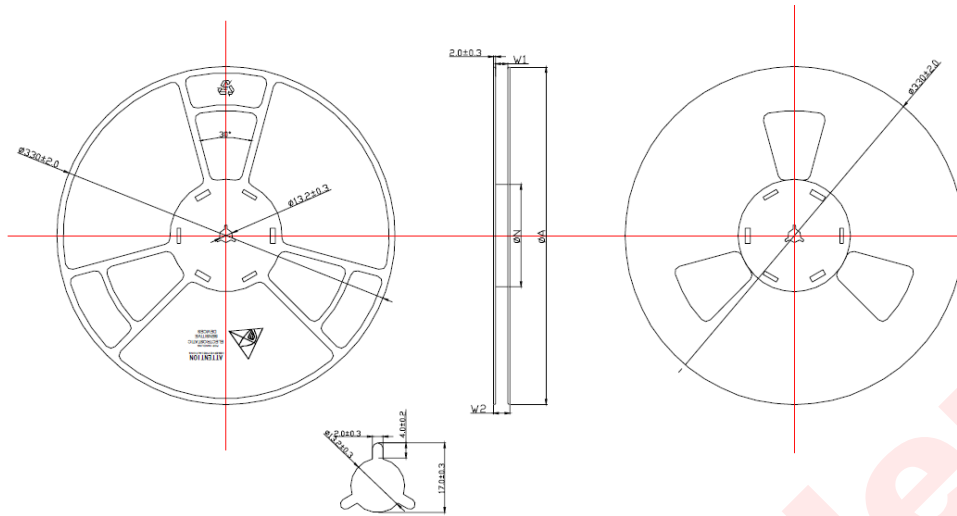

PRODUCT SPECIFICATIONS				
TYPE WIDTH	ϕA	ϕN	W1 (Min)	W2 (Max)
12MM	330 ± 2.0	100 ± 1.0	12.4	19.4

Notes:

1. Material: polystyrene
2. Flatness: maximum permissible 3mm
3. All dimensions are in millimeters
4. Surface resistivity: 10^5 to 10^{11} ohms/sq or less
5. All unmarked tolerance: ± 0.5

12 PACKAGE DESCRIPTION

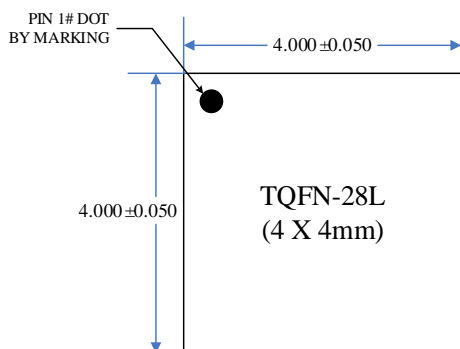

TOP VIEW

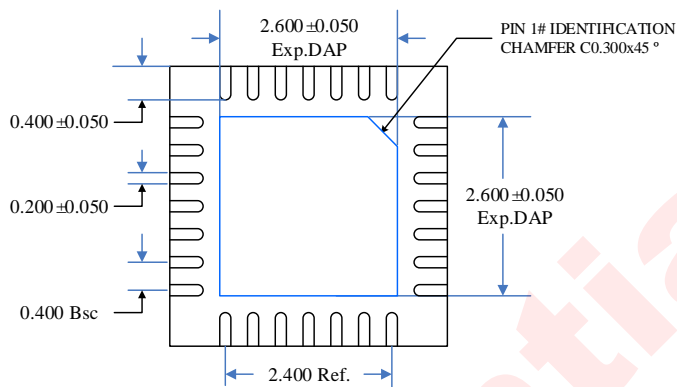

BOTTOM VIEW



SIDE VIEW

Note : All dimensions are in millimeters

13 RECOMMENDED LAND PATTERN

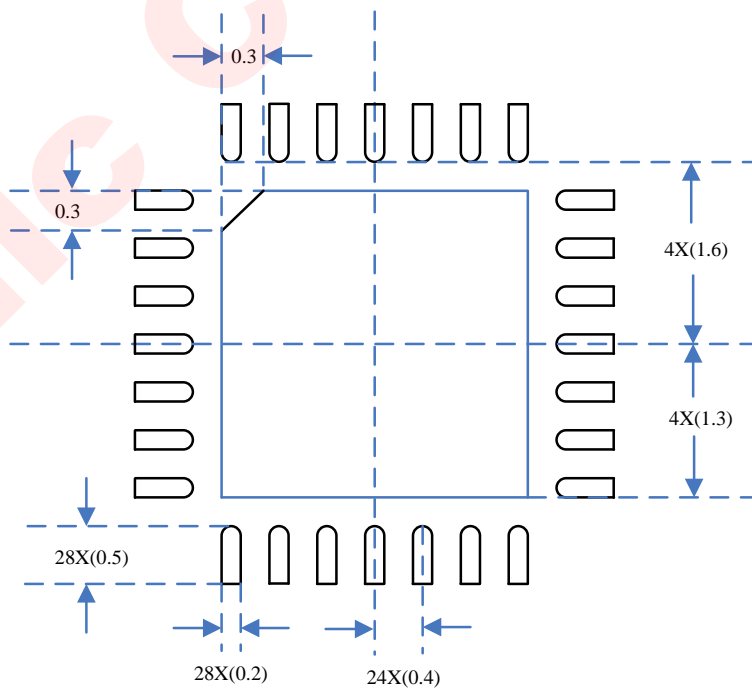

TOP VIEW

Note : All dimensions are in millimeters

14 REFLOW

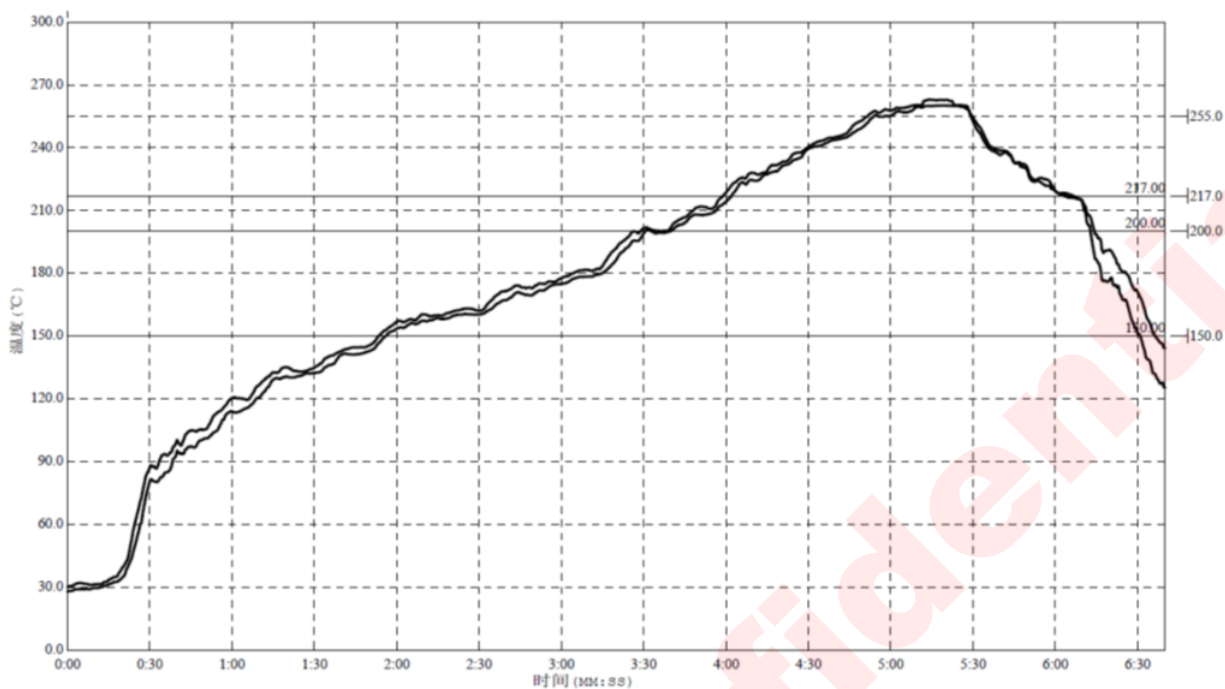

Reflow Note	Spec
Average ramp-up rate (217°C to peak)	Max. 3°C /sec
Time of Preheat temp. (from 150°C to 200°C)	60-120sec
Time to be maintained above 217°C	60-150sec
Peak Temperature	>260°C
Time within 5°C of actual peak temp	20-40sec
Ramp-down rate	Max. 6°C /sec
Time from 25°C to peak temp	Max. 8min

Package Reflow Standard Profile

NOTE 1: All data are compared with the package-top temperature, measured on the package surface;

NOTE 2: AW9120 adopted the Pb-Free assembly.

15 REVISION HISTORY

Vision	Date	Change Record
V1.0	Feb 2017	Officially Released
V1.1	Nov. 2017	Update the ordering information Add the recommended land pattern
V1.2	June 2018	Update LED brightness controller and PWM controller description Update ASP Example Update the electrical characteristics Update Ordering information Update reflow Update tape and reel information
V1.3	Sep. 2018	Update the storage temperature Update the electrical characteristics
V1.4	Feb. 2019	Add power on procedure

awinic Confidential

16 DISCLAIMER

Information in this document is believed to be accurate and reliable. However, Shanghai AWINIC Technology Co., Ltd (AWINIC Technology) does not give any representations or warranties, expressed or implied, as to the accuracy or completeness of such information and shall have no liability for the consequences of use of such information.

AWINIC Technology reserves the right to make changes to information published in this document, including without limitation specifications and product descriptions, at any time and without notice. Customers shall obtain the latest relevant information before placing orders and shall verify that such information is current and complete. This document supersedes and replaces all information supplied prior to the publication hereof.

AWINIC Technology products are not designed, authorized or warranted to be suitable for use in medical, military, aircraft, space or life support equipment, nor in applications where failure or malfunction of an AWINIC Technology product can reasonably be expected to result in personal injury, death or severe property or environmental damage. AWINIC Technology accepts no liability for inclusion and/or use of AWINIC Technology products in such equipment or applications and therefore such inclusion and/or use is at the customer's own risk.

Applications that are described herein for any of these products are for illustrative purposes only. AWINIC Technology makes no representation or warranty that such applications will be suitable for the specified use without further testing or modification.

All products are sold subject to the general terms and conditions of commercial sale supplied at the time of order acknowledgement.

Nothing in this document may be interpreted or construed as an offer to sell products that is open for acceptance or the grant, conveyance or implication of any license under any copyrights, patents or other industrial or intellectual property rights.

Reproduction of AWINIC information in AWINIC data books or data sheets is permissible only if reproduction is without alteration and is accompanied by all associated warranties, conditions, limitations, and notices. AWINIC is not responsible or liable for such altered documentation. Information of third parties may be subject to additional restrictions.

Resale of AWINIC components or services with statements different from or beyond the parameters stated by AWINIC for that component or service voids all express and any implied warranties for the associated AWINIC component or service and is an unfair and deceptive business practice. AWINIC is not responsible or liable for any such statements.