



SPECIFICATION FOR APPROVAL

File No.: O/FRK 0.GS.E.C45-C12

Product Name	Metallized Polypropylene Film Interference Suppression Capacitor (Class X1: 440Vac/480Vac)
Product Type	MKP65
Product Code	C45
Customer	
Customer Code	
Issue Date	

Xiamen Faratronic Co. Ltd.			Approved by Customer
Drafted	Checked	Approved	



厦门法拉电子股份有限公司

Xiamen Faratronic Co. Ltd.

地址: 中国厦门市海沧区新园路 99 号

Add: No.99 Xinyuan Road, Haicang District, Xiamen, China

Export business

HK office : **Faratronic (HK) Co. Ltd.**

TEL: 0086-592-6208609 6208608

0852-2898 9168

FAX: 0086-592-6208557

0852-2898 9683

Mail: Vivian@faratronic.com.cn

hkoffice@faratronic.com.hk

Donny@faratronic.com.cn

kolin@faratronic.com.hk

james@faratronic.com.cn

Http: www.faratronic.com.cn

www.faratronic.com

*.The specification are the property of Xiamen Faratronic Co.Ltd and shall not be copied or used as commercial purposes without permission.

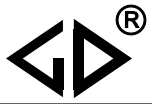

Version history

Current version	Date	Author	Change description

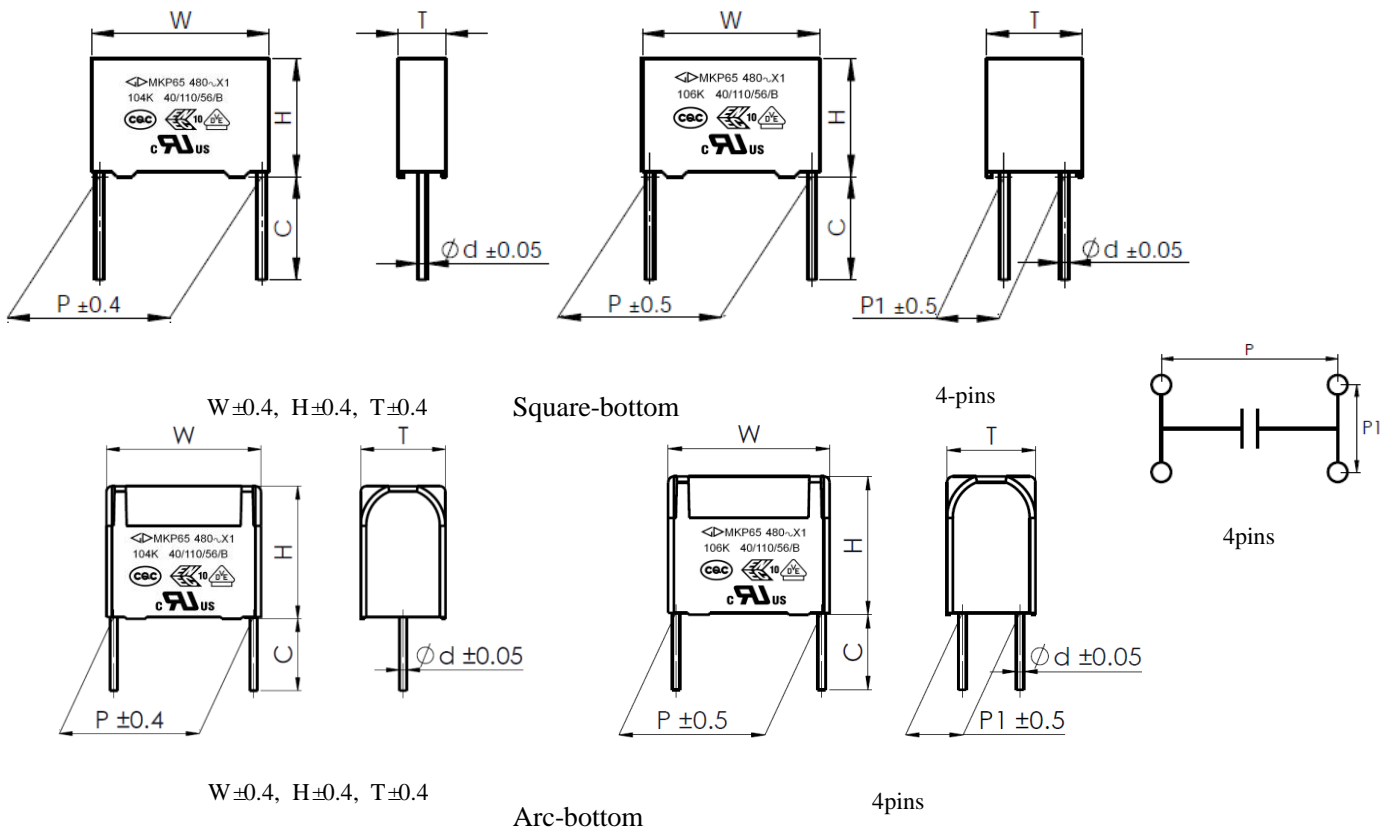
Metallized polypropylene film interference suppression capacitor (Class X1, 440Vac/480Vac)
■ Outline Drawing

■ Features

- Metallized polypropylene structure
- Compact size
- Withstanding overvoltage stressing
- Excellent active and passive flame resistant abilities
- Used in across-the-line, interference suppression circuit.

■ Safety Approvals

•	CQC	IEC 60384-14:2013, X1, 440Vac/480Vac, 0.0010μF~10.0μF, 40/110/56/B Certificate No.: CQC06001016942
•	ENEC-VDE	EN 60384-14:2013, X1, 440Vac/480Vac, 0.0010μF~10.0μF, 40/110/56/B Certificate No.: 40021925
•	UL/CUL	UL60384-14:2014, CSA E60384-14:09, X1, 440Vac/480Vac, 0.0010μF~10.0μF, 40/110/56/B File No. : E186600, CCN: FOWX2/8

■ Specifications

Class	Class X1		
Climatic Category / Passive Flammability Category	40/110/56/B		
Operating Temperature Range	-40°C ~ +110°C		
Rated Voltage (U _R)	440Vac/480Vac, 50/60Hz		
Maximum continuous DC voltage	1 000Vdc		
Capacitance Range	0.0010μF~10.0μF		
Capacitance Tolerance	±10%(K), ±20%(M)		
Voltage Proof	Between Terminals:	4.3U _R (dc), 2s	
	Between Terminals To Case:	2560 (Vac), 1min	
Insulation Resistance	R≥15 000MΩ , C _N ≤0.33μF		
	RC _N ≥5 000s, C _N >0.33μF (20°C, 100V ,1min)		
Dissipation Factor(tanδ)	0.0010μF<C _N ≤0.010μF	≤25×10 ⁻⁴ (1kHz,20°C)	≤25×10 ⁻⁴ (10kHz,20°C)
	0.010μF<C _N ≤0.47μF	≤15×10 ⁻⁴ (1kHz,20°C)	≤20×10 ⁻⁴ (10kHz,20°C)
	0.47μF<C _N ≤1.0μF	≤20×10 ⁻⁴ (1kHz,20°C)	≤40×10 ⁻⁴ (10kHz,20°C)
	1.0μF<C _N	≤30×10 ⁻⁴ (1kHz,20°C)	-----

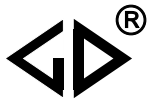

■ Part number system

The 18 digits part number is formed as follow:

1	2	3	4	5	6	7	8	9	10	11	12	13	14	15	16	17	18
C	4	5															

Digit 1 to 3 Series code

C45=MKP65

Digit 4 to 5 A.C. rated voltage

S1=440V S3=480V

Digit 6 to 8 Rated capacitance value

For example : 103=10×10³ pF= 0.01μF

Digit 9 Capacitance tolerance

K=±10%, M=±20%

Digit 10 Pitch

3=7.5 mm 4=10.0mm 6=15.0mm 9=22.5mm

B=27.5mm F=37.5mm M=52.5mm

Digit 11 Internal use

Digit 12 to 15 Lead form and packaging code

Digit 16 to 18 Internal use

Table1 Lead form and packaging code

Digit 12		Digit 13		Digit 14		Digit 15	
code	explanation	code	explanation	code	explanation	code	explanation
A	ammo-pack	4 6	F=10.0mm F=15.0mm	0	straight	5	P3=25.4mm;H=18.5mm (For pitch=10/15mm)
C	straight lead "C" in the figure above	code	explanation	0		0	Length tolerance ±0.5mm Or standard length
		00	standard lead length (18mm~26mm)				
		45	lead length 4.5mm	2		2	Length tolerance ±0.3mm
		35	lead length 3.5mm				
		32	lead length 3.2mm				
T 3	P1=20.3mm±0.5mm P1=20mm±0.5mm	45 55	lead length 4.5mm lead length 5.5mm			0	Length tolerance ±0.5mm or standard length



■ Dimensions(mm)

440Vac/480Vac#							440Vac/480Vac#							440Vac/480Vac#						
C _N (μF)	W	H	T	P	d	Part number	C _N (μF)	W	H	T	P	d	Part number	C _N (μF)	W	H	T	P	d	Part number
0.0010	10.5	9.0	4.0	7.5	0.6	C45S1102-30****++	0.056M	17.5	12.0	6.0	15.0	0.6	C45S1563M6S****++	★1.0M	32.0	16.0	27.5	27.5	0.8	C45S1105MBC****++
0.0012	10.5	9.0	4.0	7.5	0.6	C45S1122-30****++	0.056K	17.5	12.0	7.0	15.0	0.6	C45S1563K6S****++	★1.0K	32.0	18.5	31.0	27.5	0.8	C45S1105KBC****++
0.0015	10.5	9.0	4.0	7.5	0.6	C45S1152-30****++	0.068	17.5	13.5	7.5	15.0	0.6	C45S1683-6S****++	1.0	32.0	28.0	17.0	27.5	0.8	C45S1105-BA****++
0.0018	10.5	9.0	4.0	7.5	0.6	C45S1182-30****++	0.068	17.5	12.0	13.0	15.0	0.8	C45S1683-6C****++	1.0	32.0	30.0	16.0	27.5	0.8	C45S1105-BS****++
0.0022	10.5	9.0	4.0	7.5	0.6	C45S1222-30****++	0.082	17.5	14.0	8.0	15.0	0.6	C45S1823-6S****++	1.2M	32.0	30.0	16.0	27.5	0.8	C45S1125MBS****++
0.0027	10.5	9.0	4.0	7.5	0.6	C45S1272-30****++	0.10M	17.5	14.0	8.0	15.0	0.6	C45S1104M6S****++	1.2M	32.0	28.0	17.0	27.5	0.8	C45S1125MBA****++
0.0033	10.5	9.0	4.0	7.5	0.6	C45S1332-30****++	0.10K	17.5	14.5	8.5	15.0	0.6	C45S1104K6S****++	1.2K	32.0	29.0	19.0	27.5	0.8	C45S1125KBA****++
0.0039	10.5	9.0	4.0	7.5	0.6	C45S1392-30****++	0.12	17.5	16.0	10.0	15.0	0.8	C45S1124-6S****++	1.2K	32.0	33.0	18.0	27.5	0.8	C45S1125KBS****++
0.0047	10.5	9.0	4.0	7.5	0.6	C45S1472-30****++	0.15M	17.5	16.0	10.0	15.0	0.8	C45S1154M6S****++	1.5M	32.0	29.0	19.0	27.5	0.8	C45S1155MBA****++
0.0056	10.5	9.0	4.0	7.5	0.6	C45S1562-30****++	0.15K	17.5	19.0	11.0	15.0	0.8	C45S1154K6S****++	★1.5M	32.0	18.5	31.0	27.5	0.8	C45S1155MBC****++
0.0068	10.5	11.0	5.0	7.5	0.6	C45S1682-30****++	0.18	17.5	19.0	11.0	15.0	0.8	C45S1184-6S****++	1.5	32.0	33.0	18.0	27.5	0.8	C45S1155-BS****++
0.0082	10.5	11.0	5.0	7.5	0.6	C45S1822-30****++	0.039	26.5	15.0	6.0	22.5	0.8	C45S1393-90****++	1.8	32.0	37.0	22.0	27.5	0.8	C45S1185-BS****++
0.010	10.5	11.0	5.0	7.5	0.6	C45S1103-30****++	0.047	26.5	15.0	6.0	22.5	0.8	C45S1473-90****++	2.2M	32.0	37.0	22.0	27.5	0.8	C45S1225MBS****++
0.012	10.5	12.0	6.0	7.5	0.6	C45S1123-30****++	0.056	26.5	15.0	6.0	22.5	0.8	C45S1563-90****++	0.33	41.0	22.0	11.0	37.5	1.0	C45S1334-F0****++
0.015M	10.5	12.0	6.0	7.5	0.6	C45S1153M30****++	0.068	26.5	15.0	6.0	22.5	0.8	C45S1683-90****++	0.39	41.0	22.0	11.0	37.5	1.0	C45S1394-F0****++
0.0010	13.0	9.0	4.0	10.0	0.6	C45S1102-40****++	0.082	26.5	15.0	6.0	22.5	0.8	C45S1823-9S****++	0.47	41.0	22.0	11.0	37.5	1.0	C45S1474-FS****++
0.0012	13.0	9.0	4.0	10.0	0.6	C45S1122-40****++	0.10	26.5	15.0	6.0	22.5	0.8	C45S1104-9S****++	0.56	41.0	22.0	11.0	37.5	1.0	C45S1564-FS****++
0.0015	13.0	9.0	4.0	10.0	0.6	C45S1152-40****++	0.12	26.5	15.0	6.0	22.5	0.8	C45S1124-9S****++	0.68	41.0	22.0	11.0	37.5	1.0	C45S1684-FS****++
0.0018	13.0	9.0	4.0	10.0	0.6	C45S1182-40****++	0.15	26.5	16.0	7.0	22.5	0.8	C45S1154-9S****++	0.82M	41.0	22.0	11.0	37.5	1.0	C45S1824MFS****++
0.0022	13.0	9.0	4.0	10.0	0.6	C45S1222-40****++	0.18	26.5	17.0	8.5	22.5	0.8	C45S1184-9S****++	0.82K	41.0	24.0	13.0	37.5	1.0	C45S1824KFS****++
0.0027	13.0	9.0	4.0	10.0	0.6	C45S1272-40****++	0.22	26.5	17.0	8.5	22.5	0.8	C45S1224-9S****++	1.0	41.0	24.0	13.0	37.5	1.0	C45S1105-FS****++
0.0033	13.0	9.0	4.0	10.0	0.6	C45S1332-40****++	0.27	26.5	18.5	10.0	22.5	0.8	C45S1274-9S****++	1.0	42.0	15.0	24.0	37.5	1.0	C45S1105-FC****++
0.0039	13.0	9.0	4.0	10.0	0.6	C45S1392-40****++	0.33	26.5	20.0	11.0	22.5	0.8	C45S1334-9S****++	1.2	41.0	26.0	15.0	37.5	1.0	C45S1125-FA****++
0.0047	13.0	9.0	4.0	10.0	0.6	C45S1472-4S****++	0.39	26.5	20.0	11.0	22.5	0.8	C45S1474-9S****++	1.2	42.0	28.0	14.0	37.5	1.0	C45S1125-FS****++
0.0056	13.0	9.0	4.0	10.0	0.6	C45S1562-4S****++	0.47M	26.5	22.0	12.0	22.5	0.8	C45S1474M9S****++	1.5M	41.0	26.0	15.0	37.5	1.0	C45S1155MFA****++
0.0068	13.0	9.0	4.0	10.0	0.6	C45S1682-4S****++	0.47K	26.5	23.0	13.5	22.5	0.8	C45S1474K9S****++	1.5M	42.0	28.0	14.0	37.5	1.0	C45S1155MFS****++
0.0082	13.0	9.0	4.0	10.0	0.6	C45S1822-4S****++	0.56M	26.5	23.0	13.5	22.5	0.8	C45S1564M9S****++	1.5K	41.0	30.0	16.0	37.5	1.0	C45S1155KFS****++
0.010	13.0	9.0	4.0	10.0	0.6	C45S1103-4S****++	0.56K	26.5	24.5	15.5	22.5	0.8	C45S1564K9S****++	1.5	42.0	19.0	24.0	37.5	1.0	C45S1155-FC****++
0.012	13.0	11.0	5.0	10.0	0.6	C45S1123-4S****++	0.68M	26.5	24.5	15.5	22.5	0.8	C45S1684M9S****++	1.8M	41.0	30.0	16.0	37.5	1.0	C45S1185MFS****++
0.015	13.0	11.0	5.0	10.0	0.6	C45S1153-4S****++	0.15	32.0	18.0	9.0	27.5	0.8	C45S1154-B0****++	1.8K	41.0	32.0	17.0	37.5	1.0	C45S1185KFS****++
0.018	13.0	11.0	5.0	10.0	0.6	C45S1183-4S****++	0.18	32.0	18.0	9.0	27.5	0.8	C45S1184-B0****++	2.2M	41.0	32.0	17.0	37.5	1.0	C45S1225MFA****++
0.022	13.0	11.0	5.0	10.0	0.6	C45S1223-4S****++	0.22	32.0	18.0	9.0	27.5	0.8	C45S1224-B0****++	2.2	41.0	33.5	18.5	37.5	1.0	C45S1225-FS****++
0.027	13.0	12.0	6.0	10.0	0.6	C45S1273-4S****++	0.27	32.0	18.0	9.0	27.5	0.8	C45S1274-BS****++	2.7	41.0	37.0	22.0	37.5	1.0	C45S1275-FS****++
0.033	13.0	12.0	6.0	10.0	0.6	C45S1333-4S****++	0.33	32.0	18.0	9.0	27.5	0.8	C45S1334-BS****++	3.3M	41.0	37.0	22.0	37.5	1.0	C45S1335MFS****++
0.039	13.0	13.0	7.0	10.0	0.6	C45S1393-4S****++	0.33	32.0	12.0	18.0	27.5	0.8	C45S1334-BC****++	3.3K	41.0	41.0	26.0	37.5	1.0	C45S1335KFS****++
0.047M	13.0	13.0	7.0	10.0	0.6	C45S1473M4S****++	0.39	32.0	20.0	11.0	27.5	0.8	C45S1394-BS****++	3.3K	41.5	37.5	27.5	37.5	1.0	C45S1335KFA****++
0.047K	13.0	14.0	8.0	10.0	0.6	C45S1473K4S****++	0.47	32.0	20.0	11.0	27.5	0.8	C45S1474-BS****++	3.9	41.0	41.0	26.0	37.5	1.0	C45S1395-FS****++
0.056	13.0	14.0	8.0	10.0	0.6	C45S1563-4S****++	★0.47	32.0	12.0	22.0	27.5	0.8	C45S1474-BC****++	3.9	41.5	37.5	27.5	37.5	1.0	C45S1395-FA****++
0.010	17.5	9.5	5.0	15.0	0.6	C45S1103-6S****++	0.56	32.0	22.0	13.0	27.5	0.8	C45S1564-BS****++	4.7M	41.0	43.0	28.0	37.5	1.0	C45S1475MFS****++
0.012	17.5	9.5	5.0	15.0	0.6	C45S1123-6S****++	0.68M	32.0	22.0	13.0	27.5	0.8	C45S1684MBS****++	4.7K	42.0	45.0	30.0	37.5	1.0	C45S1475KFS****++
0.015	17.5	9.5	5.0	15.0	0.6	C45S1153-6S****++	0.68K	32.0	25.0	13.0	27.5	0.8	C45S1684KBA****++	★4.7	57.0	38.0	24.0	52.5	1.2	C45S1475-MST****++
0.018	17.5	9.5	5.0	15.0	0.6	C45S1183-6S****++	0.68K	32.0	24.5	15.0	27.5	0.8	C45S1684KBS****++	5.6	57.0	45.0	30.0	52.5	1.2	C45S1565-MST****++
0.022	17.5	9.5	5.0	15.0	0.6	C45S1223-6S****++	★0.68	32.0	16.0	22.0	27.5	0.8	C45S1684-BC****++	6.8	57.0	45.0	30.0	52.5	1.2	C45S1685-MST****++
0.027	17.5	11.0	5.0	15.0	0.6	C45S1273-6S****++	0.82M	32.0	25.0	13.0	27.5	0.8	C45S1824MBS****++	6.8	57.0	30.0	44.0	52.5	1.2	C45S1685-MCT****++
0.033	17.5	11.0	5.0	15.0	0.6	C45S1333-6S****++	0.82K	32.0	24.5	15.0	27.5	0.8	C45S1824KBS****++	8.2	57.0	50.0	35.0	52.5	1.2	C45S1825-MST****++
0.039	17.5	12.0	6.0	15.0	0.6	C45S1393-6S****++	0.82K	32.0	28.0	14.0	27.5	0.8	C45S1824KBA****++	10.0	57.0	50.0	35.0	52.5	1.2	C45S1106-MST****++
0.047	17.5	12.0	6.0	15.0	0.6	C45S1473-6S****++														

Note: 1. “-”=capacitance tolerance code, M=±20%,K=±10%

2. “****”=lead form and packaging code (refer to table 1)

3. “#”when the rated voltage is 480Vac,the digit 4~5 is S3.

4. “★” = Arc bottom of the outer shell

Maximum permissible voltage change per unit of time

Rated Voltage (Vac)	dV/dt(V/us) at 680 Vdc				
	P=10mm	P=15mm	P=22.5mm	P=27.5mm	P=37.5mm
440	750	600	300	225	150

Note: 1. Rated voltage pulse slope (dV/dt)_R at rated voltage.

2. If the working voltage(U) is lower than the rated voltage(U_R),the capacitor can be worked at a higher dV/dt. In this case, the maximum allowed dV/dt is obtain by multiplying the right value with U_R/U.

Test Method And Performance

No.	Item	Performance	Test Method (IEC 60384-14)
1	4.5 Solderability	Good quality of tinning	Solder temperature: 245°C ±5°C Immersion time: 2.0s±0.5s
2	4.3 Terminal strength	There shall be no visible damage	Tense: 0.50<d≤0.80, 10N 0.80<d≤1.25, 20N Bend: 0.50<d≤0.80, 5N 0.80<d≤1.25, 10N The terminals shall be bent 2 times in each direction
3	4.4 Resistance to solder heat	There shall be no visible damage ΔC/C ≤±5%(relative to the initial value)	Solder temperature:260°C±5°C Immersion time: 10s±1s
4	4.20 Solvent resistance of the marking	The marking shall be legible	Solvent: Industrial isopropanol. Solvent temperature:23°C±5°C Dipping time: 5min±0.5min Condition: scrub Scrub material: absorbent cotton Reverting time: No
5	4.2 Initial measurement	Capacitance, Tgδ	
	4.6 Rapid change of temperature	There shall be no evidence of deterioration.	θ _A =-40°C, θ _B =+110°C 5 cycles Duration: t=30min
	4.7 Vibration	There shall be no evidence of deterioration.	Amplitude 0.75mm or acceleration 98m/s ² (whichever is the smaller severity), f: 10Hz to 500Hz. Three directions, 2h for each direction,total 6h.
	4.8 Bump	There shall be no evidence of deterioration.	4 000 times, Acceleration: 400m/s ² , Pulse duration, 6ms
	Final measurement	There shall be no visible damage ΔC/C ≤±5%(relative to the initial value)	
6	4.11 Climate sequence	Initial measurement	
		Dry heat	+110°C, 16h
		Damp heat, Cyclic	Test Db, Severity: b, the first cycle
		Cold	-40°C, 2h
		Damp heat, cyclic other	Test Db, Severity b, the other cycles
		Final measurement	There shall be no visible damage, legible marking ΔC/C ≤±5%(relative to the initial value) Increase of tgδ: C _N ≤1μF: ≤0.008 (10kHz) C _N >1μF: ≤0.005 (1kHz) Dielectric strength : there shall be no permanent breakdown or flashover I.R.: ≥ 50% of the rated value

No.	Item	Performance	Test Method (IEC 60384-14)
7	4.12 Damp heat steady state	There shall be no visible damage, legible marking $\Delta C/C \leq \pm 5\%$ (relative to the initial value) Increase of $\text{tg}\delta$: $C_N \leq 1\mu\text{F}$: ≤ 0.008 (10kHz) $C_N > 1\mu\text{F}$: ≤ 0.005 (1kHz) Dielectric strength : there shall be no permanent breakdown or flashover I.R.: $\geq 50\%$ of the rated value	Temperature: $40^\circ\text{C} \pm 2^\circ\text{C}$ Humidity: $93 \pm 2\%$ RH Duration: 56 days
8	4.13 Impulse voltage	There are three or more waveforms which indicate that no self-heating breakdown have occurred when it is monitored by the monitor	Each individual capacitor shall be subjected to 24 impulses of the same polarity (when any three successive impulses are shown by the monitor to have a wave form indicating that no self-healing breakdown have taken place the impulses can be stopped), the time between impulses shall not be less than 10s, and the peak value of the voltage impulse: 4.0kV (suitable for $C_N \leq 1\mu\text{F}$; When $C_N > 1\mu\text{F}$, the capacitor can endure pulse voltage value is $4.0/\sqrt{C_N}$ kV)
9	4.14 Endurance	There shall be no visible damage, legible marking $\Delta C/C \leq \pm 10\%$ (relative to the initial value) Increase of $\text{tg}\delta$: $C_N \leq 1\mu\text{F}$: ≤ 0.008 (10kHz) $C_N > 1\mu\text{F}$: ≤ 0.005 (1kHz) Dielectric strength : There shall be no breakdown or flashover I.R. : $\geq 50\%$ of the rated value	$+110^\circ\text{C}$, $1.25U_R$ V.a.c., 1 000h The voltage shall be subjected to 1000Vrms for 0.1s every one hour during test.
10	4.15 Charging and discharging	$\Delta C/C \leq \pm 10\%$ (relative to the initial value) Increase of $\text{tg}\delta$: $C_N \leq 1\mu\text{F}$: ≤ 0.008 (10kHz) $C_N > 1\mu\text{F}$: ≤ 0.005 (1kHz) I.R.: $\geq 50\%$ of the rated value	Times: 10 000 Duration of charging: 0.5s Duration of discharging: 0.5s Charging voltage: $\sqrt{2} U_R$ V.d.c. Charging resistance: $220/C_N$ (Ω) or the current $\leq 1.0\text{A}$ (whichever is the minor) Discharging resistance: $R = \frac{\sqrt{2}U_R}{C_N \times \frac{dU}{dt}} (\Omega)$ C_N : Capacitance (μF)
11	4.17 Passive flammability	The flaming time of each capacitor shall not go beyond 10s after it is taken apart from the flame. Drop of each capacitor caused by flame shall not fire the tissue below.	Needle flame test The category of flammability: B Expose time: 1 time Capacitor Volume Exposing time $250 < V(\text{mm}^3) \leq 500$ 20s $500 < V(\text{mm}^3) \leq 1750$ 30s $V(\text{mm}^3) > 1750$ 60s

No.	Item	Performance	Test Method (IEC 60384-14)
12	4.18 Active flammability	The cheese cloth around the capacitor shall not burn with a flame.	The specimens shall be individually wrapped in at least 1, but not more than 2, complete layers of cheesecloth, the cheesecloth shall be untreated pure cotton cloth. Each sample shall be subjected to 20 discharges, the interval between successive discharges shall be 5s. $U_i = 4.0kV_0^{+7} \%$ U_R be applied and be maintained for 120_0^{+10} s after the last discharge.

Quality ensuring test (before shipment):

Inspection item (each batch)	Inspection level (GB/T 2828.1, ISO2859-1)	
	IL	AQL
Appearance inspection	II	1.5%
Dimensions		
Capacitance	II	0.25%
Tangent of the loss angle		
Dielectric strength		
Insulation resistance		
Solderability	S-3	2.5%

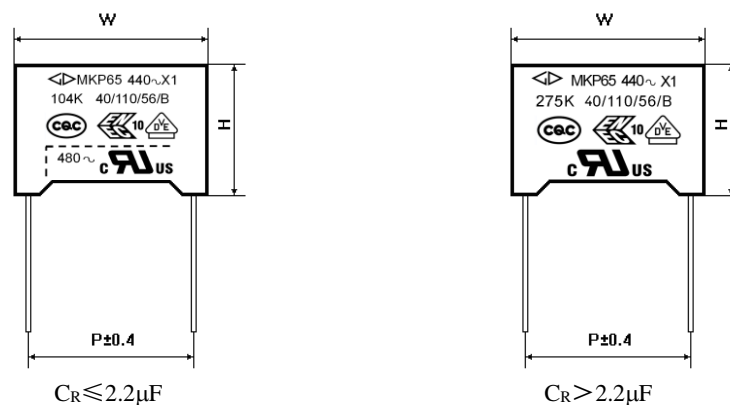
Marking

Marking Introduction:

Sign	explain	Sign	explain
	Brand	40/110/56/B	Climate category / Passive Flammability Class
MKP65	Type		CQC Approval
440~	Rated voltage		ENEC-VDE Approval
X1	Class		UL&CUL Approval
104K/275K	Rated capacitance and tolerance	480~	Rated voltage(UL/CUL)

■ Taping specification for box-type capacitors

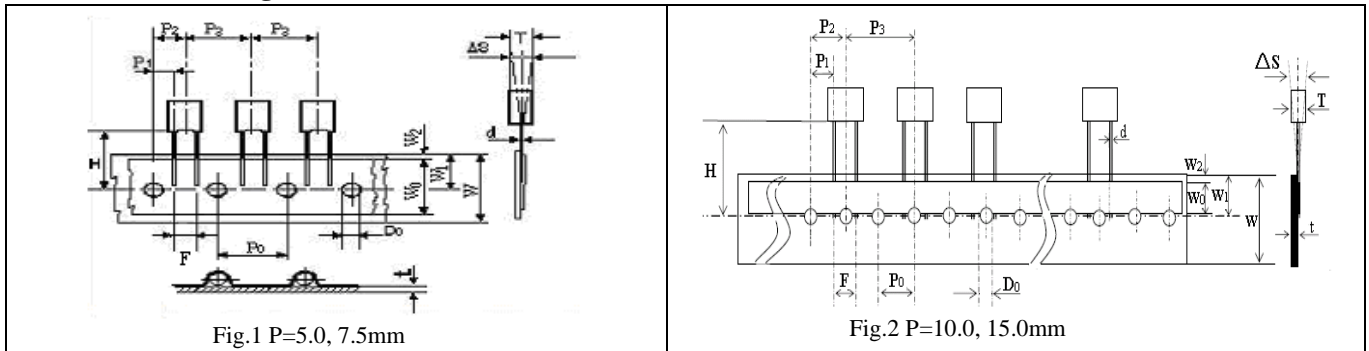
▲ Outline Drawing



▲ Taping Dimensions(mm)

Technology index title	Code	Dimensions				Tolerance
		P=5.0	P=7.5	P=10.0	P=15.0	
Taping type	—	Fig 1	Fig 1	Fig2	Fig 2	—
Part number Digit12-15	Ammo-pack	A201	A301	A405	A605	
Taping pitch	P ₃	12.7	12.7	25.4	25.4	±1.0
Feed hole pitch	P ₀	12.7	12.7	12.7	12.7	±0.3
Center of wire	P ₁	3.85	2.6	7.7	5.2	±0.7
Center of body	P ₂	6.35	6.35	12.7	12.7	±1.3
Pitch of tapping wire	F**	5.0	7.5	10.0	15.0	+0.6 -0.1
Component alignment	△S	0	0	0	0	±2.0
Height of component from tape center	H***	18.5	18.5	18.5	18.5	±0.5
Carrier tape width	W	18.0	18.0	18.0	18.0	+1.0 -0.5
Hold down tape width	W ₀	6min	10min	10min	10min	—
Hole position	W ₁	9.0	9.0	9.0	9.0	±0.5
Hold down tape position	W ₂	3max	3max	3max	3max	—
Feed hole dia.	D ₀	4.0	4.0	4.0	4.0	±0.2
Tape thickness	t	0.7	0.7	0.7	0.7	±0.2

▲ Packing Quantity

Pitch (mm)	Box thickness T(mm)	Ammo-pack (pcs/box)	
		Domestic	Export
5.0	2.5	2500	2 000
	3.5	1 700	1 500
	4.5	1 400	1 300
	5.0	1 200	1 000
7.5	6.0	1 000	800
	3.5	1 700	1 500
	4.0	1 500	1 350
	5.0	1 200	1 050
10.0/ 15.0	6.0	1 000	850
	4.0	750	650
	5.0	600	500
15.0	6.0	500	450
	7.5	400	350
	8.5	350	300
	10.0	300	250
	11.0	250	220

Note: * P₀=15mm is also available;

**F can be other lead spacing;

***H=16.5mm is available;

■ Packing box sizes(mm)

1. Out packing box for bulk

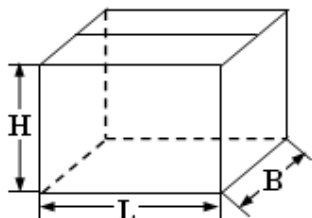

L:375±5
B:375±5
H:265±5

2. Inner packing box for bulk

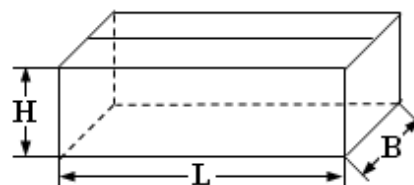

L:355±3
B:175±3
H:118±3

3. Box sizes for Ammo-pack

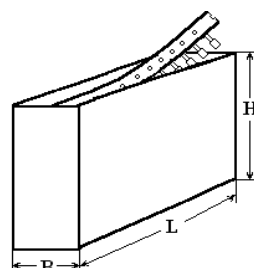

L:330±3
B:48±3
H:260±3