

XD74LS139 DIP16 / XL74LS139 SOP16

These Schottky-clamped TTL MSI circuits are designed to be used in high-performance memory-decoding or data-routing applications requiring very short propagation delay times. In high-performance memory systems, these decoders can be used to minimize the effects of system decoding. When employed with high-speed memories utilizing a fast-enable circuit, the delay times of these decoders and the enable time of the memory are usually less than the typical access time of the memory. This means that the effective system delay introduced by the Schottky-clamped system decoder is negligible.

The circuit comprises two individual two-line to four-line decoders in a single package. The active-low enable input can be used as a data line in demultiplexing applications.

All of these decoders/demultiplexers feature fully buffered inputs, each of which represents only one normalized load to its driving circuit. All inputs are clamped with high-performance Schottky diodes to suppress line-ringing and to simplify system design. The XD74LS139 and XL74LS139 are characterized for operation range of -55°C to 125°C. The XD74LS139 and XL74LS139 are characterized for operation from 0°C to 70°C.

FUNCTION TABLE

INPUTS			OUTPUTS			
ENABLE \bar{G}	SELECT		Y0	Y1	Y2	Y3
	B	A				
H	X	X	H	H	H	H
L	L	L	L	H	H	H
L	L	H	H	L	H	H
L	H	L	H	H	L	H
L	H	H	H	H	H	L

H = high level, L = low level, X = irrelevant

XD74LS139... J OR W PACKAGE
 XL74LS139... D OR N PACKAGE

(TOP VIEW)

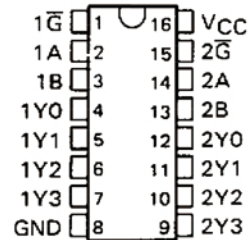

... FK PACKAGE

(TOP VIEW)

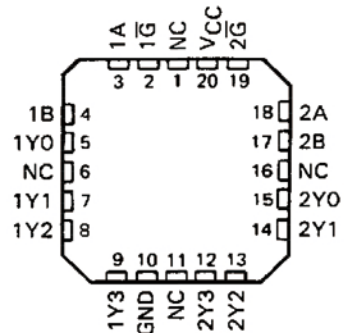

NC—No internal connection

logic symbols (alternatives) †

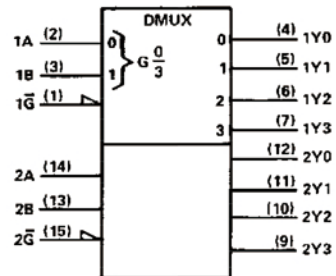
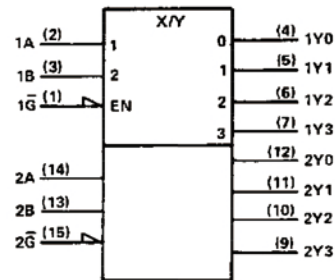

XD74LS139 DIP16 / XL74LS139 SOP16

logic diagram (positive logic)

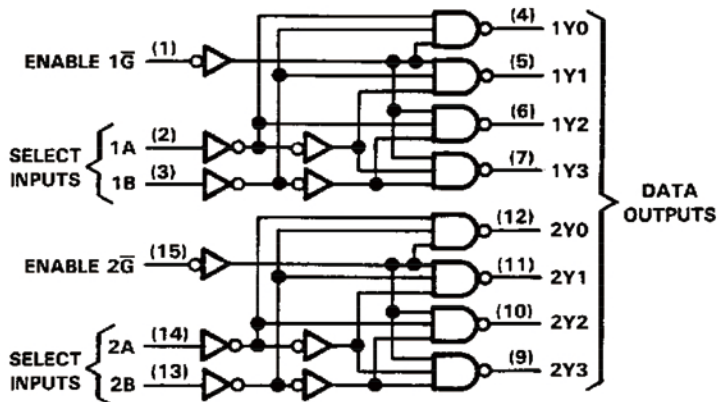

Pin numbers shown are for D, J, N, and W packages.

schematics of inputs and outputs

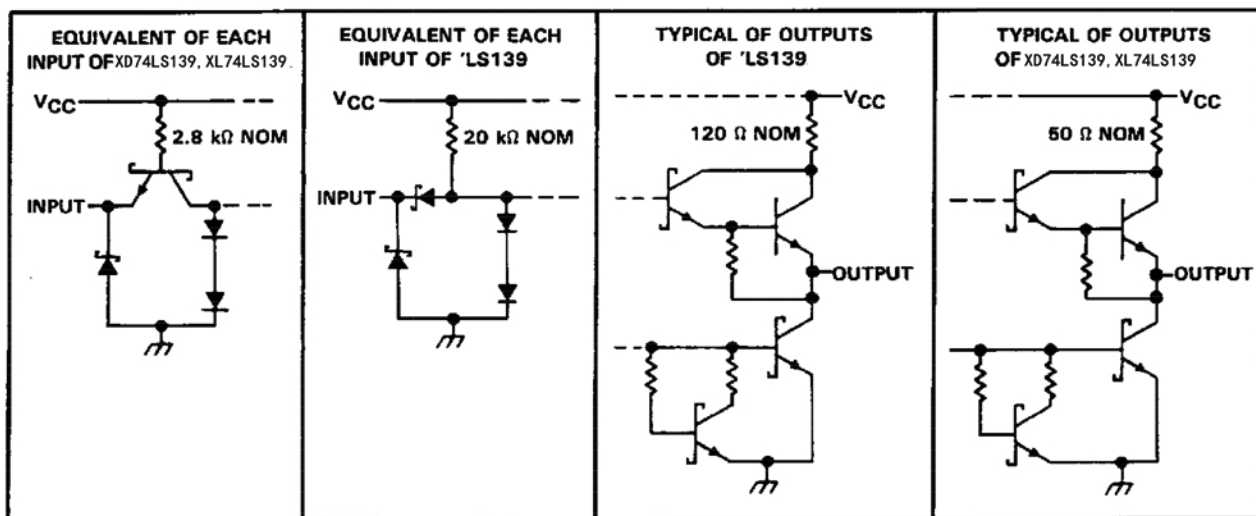

absolute maximum ratings over operating free-air temperature range (unless otherwise noted)

Supply voltage, V_{CC} (See Note 1)	7 V
Input voltage: 'LS139	7 V
74LS139	5.5 V
Operating free-air temperature range: XD74LS139	-55°C to 125°C
XL74LS139	0°C to 70°C
Storage temperature range	-65°C to 150°C

NOTE 1: Voltage values are with respect to network ground terminal.

XD74LS139 DIP16 / XL74LS139 SOP16

recommended operating conditions

		XD74LS139			XL74LS139			UNIT		
		MIN	NOM	MAX	MIN	NOM	MAX			
V _{CC}	Supply voltage	4.5	5	5.5	4.75	5	5.25	V		
V _{IH}	High-level input voltage	2			2			V		
V _{IL}	Low-level input voltage	0.7			0.8			V		
I _{OH}	High-level output current	-0.4			-0.4			mA		
I _{OL}	Low-level output current	4			8			mA		
T _A	Operating free-air temperature	-55			125			0	70	°C

electrical characteristics over recommended operating free-air temperature range (unless otherwise noted)

PARAMETER	TEST CONDITIONS†	XD74LS139			XL74LS139			UNIT		
		MIN	TYP‡	MAX	MIN	TYP‡	MAX			
V _{IK}	V _{CC} = MIN, I _I = -18 mA	-1.5			-1.5			V		
V _{OH}	V _{CC} = MIN, V _{IH} = 2 V, V _{IL} = MAX, I _{OH} = -0.4 mA	2.5	3.4		2.7	3.4		V		
V _{OL}	V _{CC} = MIN, V _{IH} = 2 V, V _{IL} = MAX	I _{OL} = 4 mA		0.25	0.4	0.25	0.4	V		
		I _{OL} = 8 mA		0.35		0.5				
I _I	V _{CC} = MAX, V _I = 7 V	0.1			0.1			mA		
I _{IH}	V _{CC} = MAX, V _I = 2.7 V	20			20			μA		
I _{IL}	V _{CC} = MAX, V _I = 0.4 V	-0.4			-0.4			mA		
I _{OS} §	V _{CC} = MAX	-20		-100		-20		-100		mA
I _{CC}	V _{CC} = MAX, Outputs enabled and open	6.8		11		6.8		11		mA

† For conditions shown as MIN or MAX, use the appropriate value specified under recommended operating conditions.

‡ All typical values are at V_{CC} = 5 V, T_A = 25°C.

§ Not more than one output should be shorted at a time, and duration of the short circuit test should not exceed one second.

switching characteristics, V_{CC} = 5 V, T_A = 25°C (see Note 2)

PARAMETER†	FROM (INPUT)	TO (OUTPUT)	LEVELS OF DELAY	TEST CONDITIONS	XD74LS139 XL74LS139			UNIT
					MIN	TYP	MAX	
t _{PLH}	Binary Select	Any	2	R _L = 2 kΩ, C _L = 15 pF	13	20		ns
t _{PHL}					22	33		ns
t _{PLH}			3		18	29		ns
t _{PHL}					25	38		ns
t _{PLH}	Enable	Any	2		16	24		ns
t _{PHL}					21	32		ns

† t_{PLH} = propagation delay time, low-to-high-level output

t_{PHL} = propagation delay time, high-to-low-level output

NOTE 2: Load circuits and voltage waveforms are shown in Section 1.

XD74LS139 DIP16 / XL74LS139 SOP16

recommended operating conditions

		XD74LS139			XL74LS139			UNIT
		MIN	NOM	MAX	MIN	NOM	MAX	
V _{CC}	Supply voltage	4.5	5	5.5	4.75	5	5.25	V
V _{IH}	High-level input voltage	2			2			V
V _{IL}	Low-level input voltage				0.8			V
I _{OH}	High-level output current				-1			mA
I _{OL}	Low-level output current				20			mA
T _A	Operating free-air temperature	-55			125			°C

electrical characteristics over recommended operating free-air temperature range (unless otherwise noted)

PARAMETER	TEST CONDITIONS†		XD74LS139 XL74LS139			UNIT	
			MIN	TYP‡	MAX		
V _{IK}	V _{CC} = MIN, I _I = -18 mA		-1.2			V	
V _{OH}	V _{CC} = MIN, V _{IH} = 2 V, V _{IL} = 0.8 V, I _{OH} = -1 mA	XD74LS139	2.5	3.4		V	
		XL74LS139	2.7	3.4			
V _{OL}	V _{CC} = MIN, V _{IH} = 2 V, V _{IL} = 0.8 V, I _{OL} = 20 mA		0.5			V	
I _I	V _{CC} = MAX, V _I = 5.5 V		1			mA	
I _{IH}	V _{CC} = MAX, V _I = 2.7 V		50			μA	
I _{IL}	V _{CC} = MAX, V _I = 0.5 V		-2			mA	
I _{OS} §	V _{CC} = MAX		-40			-100	mA
I _{CC}	V _{CC} = MAX, Outputs enabled and open		60			90	mA

† For conditions shown as MIN or MAX, use the appropriate value specified under recommended operating conditions.

‡ All typical values are at V_{CC} = 5 V, T_A = 25°C.

§ Not more than one output should be shorted at a time, and duration of the short circuit test should not exceed one second.

switching characteristics, V_{CC} = 5 V, T_A = 25°C (see Note 2)

PARAMETER†	FROM (INPUT)	TO (OUTPUT)	LEVELS OF DELAY	TEST CONDITIONS	XD74LS139 XL74LS139			UNIT
					MIN	TYP	MAX	
t _{PLH}	Binary Select	Any	2	R _L = 280 Ω, C _L = 15 pF	5	7.5		ns
t _{PHL}					6.5	10		ns
t _{PLH}			3		7	12		ns
t _{PHL}					8	12		ns
t _{PLH}	Enable	Any	2		5	8		ns
t _{PHL}					6.5	10		ns

† t_{PLH} = propagation delay time, low-to-high-level output

t_{PHL} = propagation delay time, high-to-low-level output

NOTE 2: Load circuits and voltage waveforms are shown in Section 1.

以上信息仅供参考. 如需帮助联系客服人员. 谢谢 XINLUDA