



650V 4A N-Channel Planar MOSFET

General Description

HS4N65 is Fortunatus high voltage MOSFET family based on advanced planar stripe DMOS technology. This advanced MOSFET family has optimized on-state resistance, and also provides superior switching performance and higher avalanche energy strength. This device family is suitable for high efficiency switch mode power supplies.

FEATURES

- $R_{DS(on)} \leq 3.0\Omega$ @ $V_{GS}=10V, I_D=2A$
- Ultra Low gate Charge (typical 13 nC)
- Low Crss (typical 5pF)
- Fast switching capability
- 100% avalanche tested
- Improved dv/dt capability

SYMBOL

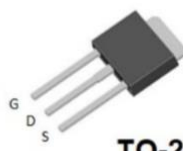
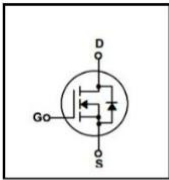

ASSEMBLY MESSAGE

Product Name	Marking	Package	Halogen Free	Packaging
HSD4N65	4N65UF	TO-251	YES	Tube
HSU4N65	4N65DF	TO-252	YES	Tube/Reel
HSP4N65	4N65CF	TO-220	YES	Tube
HSF4N65	4N65FF	TO-220F	YES	Tube

ABSOLUTE MAXIMUM RATINGS (T_C=25°C unless otherwise noted)

Parameter	Symbol	Rating			Unit
		HSD/U4N65	HSP4N65	HSF4N65	
Drain-Source Voltage	V _{DSS}	650			V
Drain Current	Continuous (T _C = 25°C)	4			A
	Continuous (T _C = 100°C)	2.7			A
Drain Current	Pulsed (Note1)	16			A
Gate-Source Voltage	V _{GSS}	±30			V
Avalanche Energy	Single Pulse (Note2)	232			mJ
	Repetitive (None1)	15			mJ
Avalanche Current (None1)	I _{AR}	4			A
Peak Diode Recovery dv/dt (Note3)	dv/dt	5			V/ns
Power Dissipation (Note 2)	T _C = 25°C	80	102	38	W
	Derate above 25°C	0.64	0.82	0.3	W/°C
Maximum Junction Temperature	T _J	150			°C
Storage Temperature Range	T _{STG}	-55 to 150			°C

- Note:**
1. Repetitive Rating: Pulse width limited by maximum junction temperature
 2. L=29mH, I_{AS}=4.0A, V_{DD}=50V, R_G=25 Ω, Starting T_J = 25°C
 3. I_{SD} ≤ 4.0A, di/dt ≤ 300A/μs, V_{DD} ≤ B_VD_{SS}, Starting T_J = 25°C



THERMAL CHARACTERISTICS

Parameter	Symbol	Max.			Unit
		HSD/U4N65	HSP4N65	HSF4N65	
Thermal Resistance, Junction-to-Case	$R_{\theta JC}$	1.56	1.23	3.29	°C/W
Thermal Resistance, Junction-to-Ambient	$R_{\theta JA}$	110	62	120	°C/W

ELECTRICAL CHARACTERISTICS ($T = 25^{\circ}\text{C}$, unless otherwise Noted)

Parameter	Symbol	Test Condition	Min.	Typ.	Max.	Unit
OFF CHARACTERISTICS						
Drain-Source Breakdown Voltage	BV_{DSS}	$V_{GS}=0V, I_D=250\mu A$	650			V
Zero Gate Voltage Drain Current	I_{DSS}	$V_{DS}=650V, V_{GS}=0V$			1	μA
		$V_{DS}=520V, T_C = 125^{\circ}\text{C}$			100	μA
Gate-Body Leakage Current, Forward	I_{GSS}	$V_{GS}=30V$			100	nA
Gate-Body Leakage Current, Reverse		$V_{GS}=-30V$			-100	nA
Breakdown Voltage Temperature Coefficient	$\frac{\Delta BV_{DSS}}{\Delta T_J}$	$I_D = 250 \mu A$		0.62		$^{\circ}\text{C}^{-1}$
ON CHARACTERISTICS						
Gate Threshold Voltage	$V_{GS(TH)}$	$V_{DS}=V_{GS}, I_D=250\mu A$	2		4	V
Drain-Source On-State Resistance	$R_{DS(ON)}$	$V_{GS}=10V, I_D=2A$		2.6	3.0	Ω
Forward Transconductance (Note4)	g_{FS}	$V_{DS} = 50V, I_D = 2A$		2.5		S
DYNAMIC PARAMETERS						
Input Capacitance	C_{ISS}	$V_{DS}=25V, V_{GS}=0V,$ $f=1.0\text{MHz}$		545		pF
Output Capacitance	C_{OSS}			54		pF
Reverse Transfer Capacitance	C_{RSS}			5		pF
SWITCHING PARAMETERS						
Turn-ON Delay Time	$t_{D(ON)}$	$V_{DD}=325V, I_D=4 A, V_{GS}$ $= 10V, R_G=10\Omega$ (Note4,5)		11		ns
Turn-ON Rise Time	t_r			25		ns
Turn-OFF Delay Time	$t_{D(OFF)}$			32.5		ns
Turn-OFF Fall-Time	t_f			7		ns
Total Gate Charge(Note)	Q_G	$V_{DS} = 520V, V_{GS} = 10V,$ $I_D = 4A$ (Note4,5)		13		nC
Gate Source Charge	Q_{GS}			3.4		nC
Gate Drain Charge	Q_{GD}			7		nC
SOURCE- DRAIN DIODE RATINGS AND CHARACTERISTICS						
Drain-Source Diode Forward Voltage	V_{SD}	$I_S=4A, V_{GS}=0V$			1.4	V
Diode Continuous Forward Current	I_S				4	A
Pulsed Drain-Source Current	I_{SM}				16	A
Reverse Recovery Time	t_{RR}	$V_{GS}=0V, I_{SD}=4A$		510		ns
Reverse Recovery Charge	Q_{RR}	$di/dt=100 A/\mu s$ (Note4,5)		2.5		μC

Note: 4. Pulse Test : Pulse width $\leq 300\mu s$, Duty cycle $\leq 2\%$

5. Essentially independent of operating temperature



TYPICAL CHARACTERISTICS

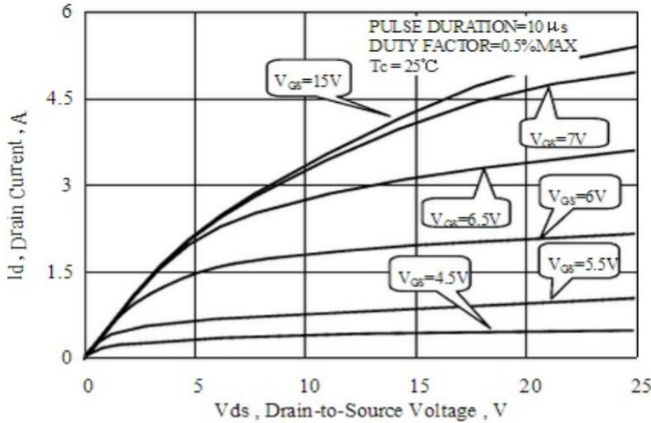

Figure 1. Typical Output Characteristics

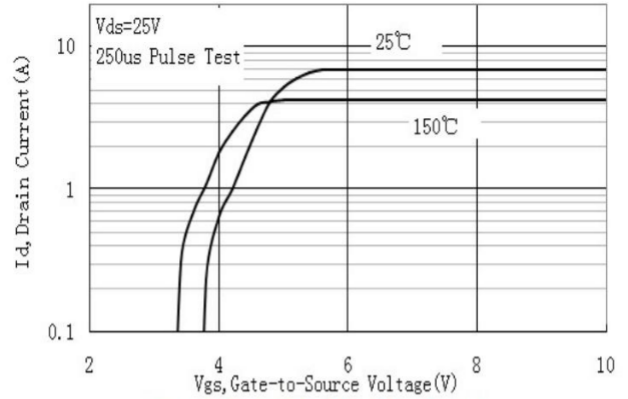

Figure 2. Typical Transfer Characteristics

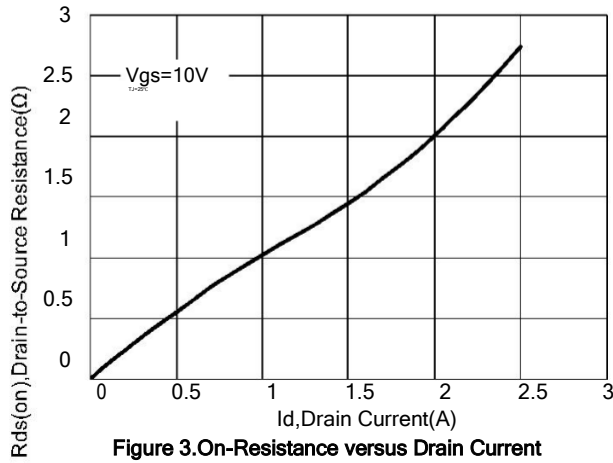

Figure 3. On-Resistance versus Drain Current

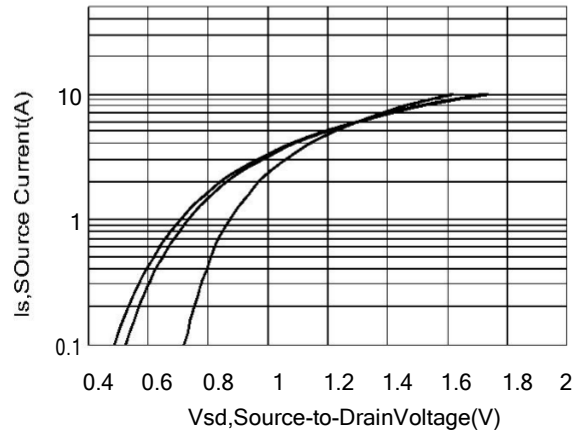

Figure 4. Diode Forward Voltage versus Current

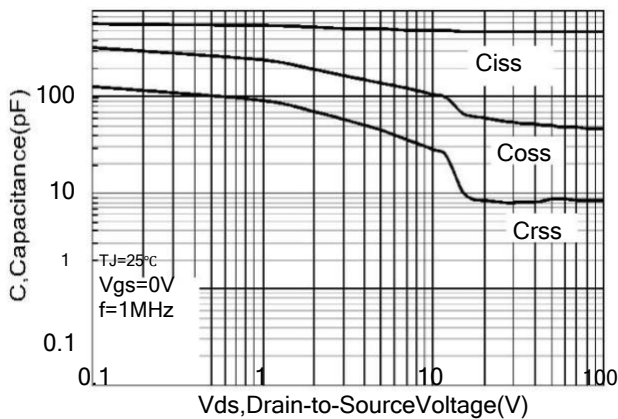

Figure 5. Typical Capacitance vs. Drain-to-Source Voltage

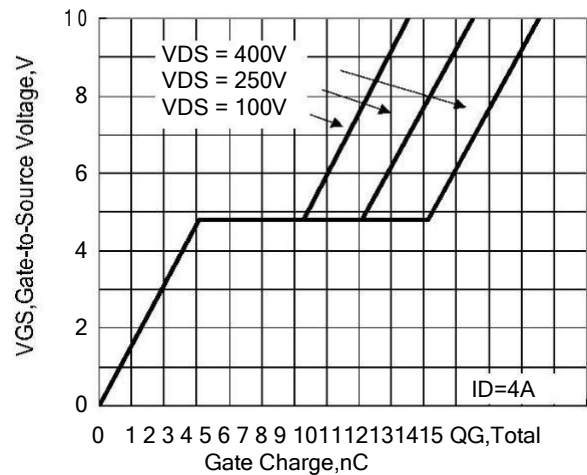

Figure 6. Typical Gate Charge vs. Vgs



TYPICAL CHARACTERISTICS(Cont.)

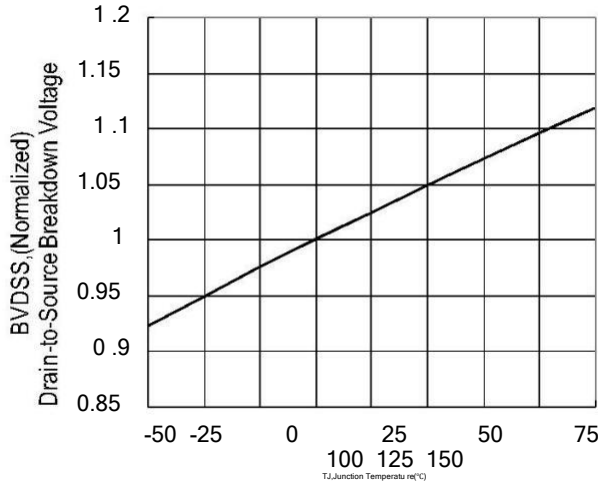

Figure 7. Bvdss Variation with Temperature

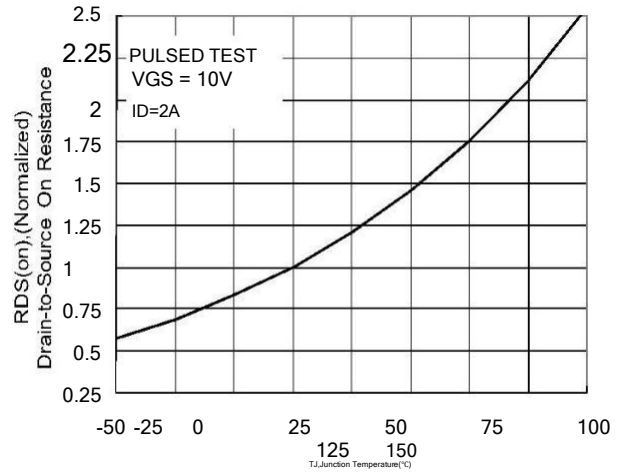

Figure 8. On-Resistance Variation with Temperature

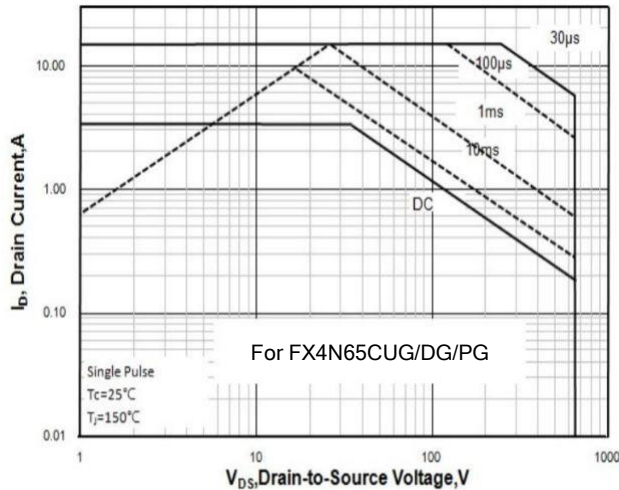

Figure 9. Maximum Safe Operating Area

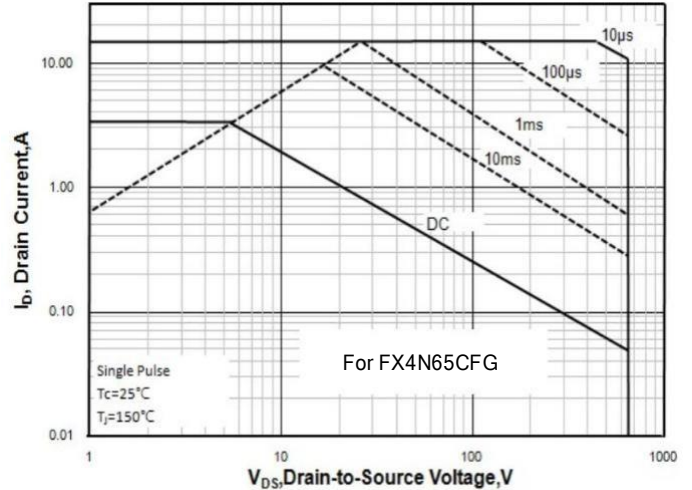

Figure 9. Maximum Safe Operating Area

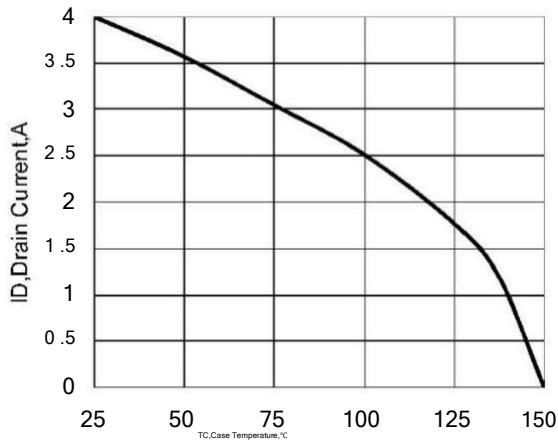
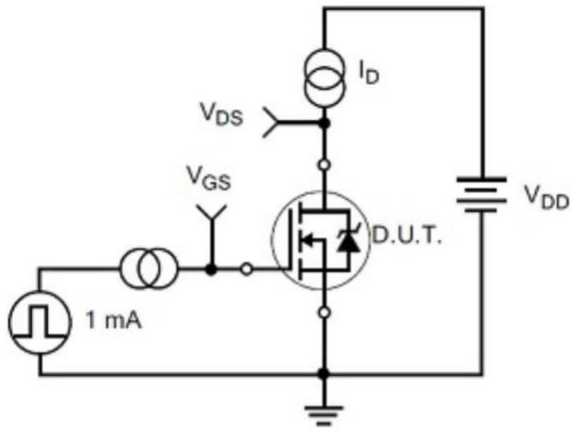
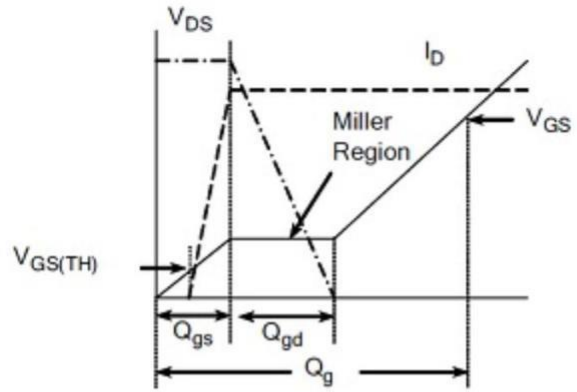

Figure 10. Maximum Continuous Drain Current vs Case Temperature

TEST CIRCUITS AND WAVEFORMS



Gate Charge Test Circuit



Gate Charge Waveform

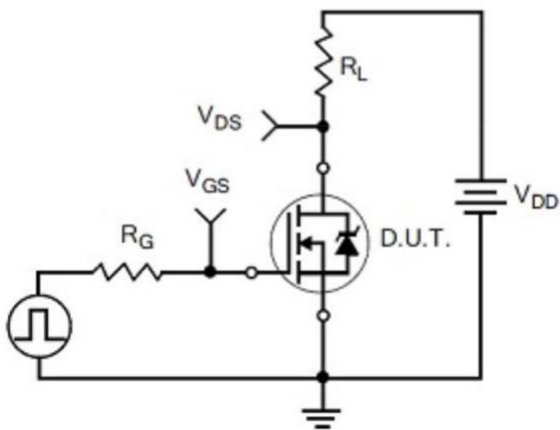

Resistive Switching Test Circuit

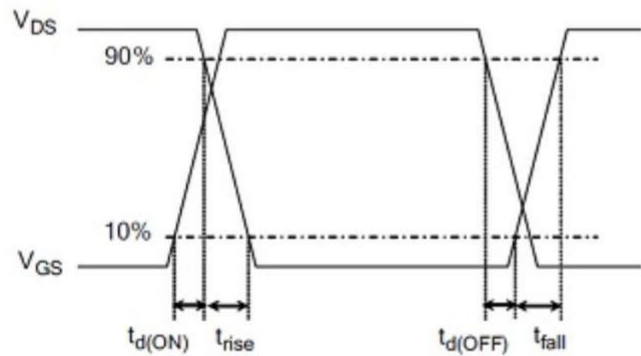

Resistive Switching Waveforms

TEST CIRCUITS AND WAVEFORMS(Cont.)

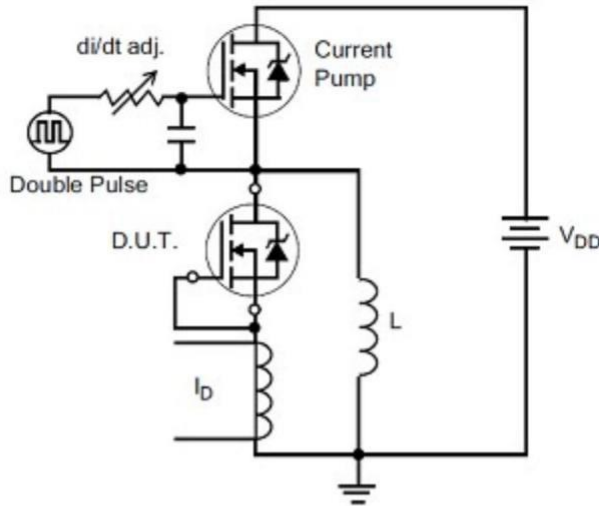

Diode Reverse Recovery Test Circuit

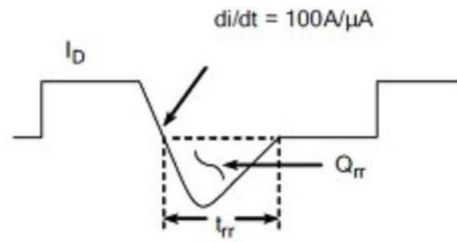

Diode Reverse Recovery Waveform

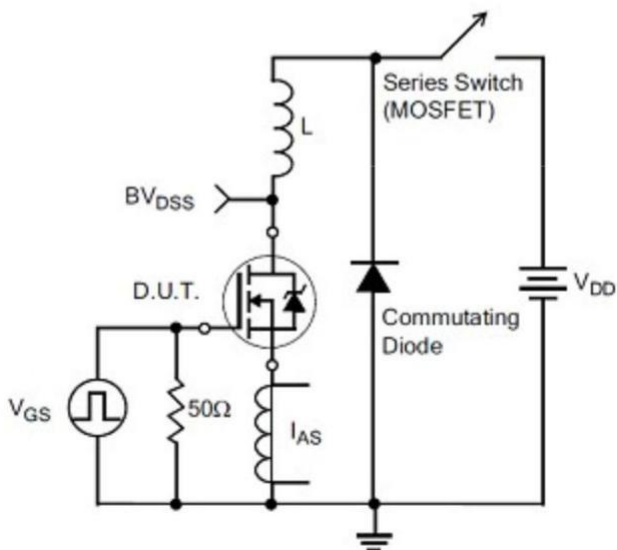

Unclamped Inductive Switching Test Circuit

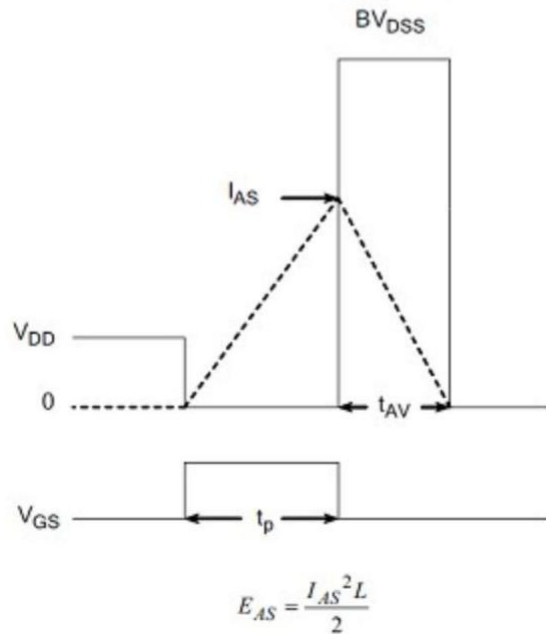

Unclamped Inductive Switching Waveforms