

Full-Bridge PWM Motor Driver

Features

- H-Bridge Motor Driver
- Low Typical $R_{DS(on)}$ MOSFETs (0.6Ω HS+LS)
- Low-Power Sleep Mode
- 100% PWM Supported
- 6.5V to 40V Operating Supply Voltage Range
- Protection Features:
 - VBB Undervoltage Lockout (UVLO)
 - Overcurrent Protection (OCP)
 - Short-to-Supply Protection
 - Short-to-Ground Protection
 - Over-temperature Shutdown Protection (OTS)
 - Fault Condition Indication Pin (nFAULT)

Applications

- Printers
- Industrial Automation
- Robotics

General Description

The G2057/G2057A provides a versatile motor driver solution with a variety of capabilities. The device contains a full H-bridge which can be used to drive a brushed DC motor, one winding of a stepper motor, or other devices such as solenoids. Two logic inputs provide directly interfacing to controller circuits.

The output stages use four N-channel power MOSFETs configured as an H-bridge. The G2057/G2057A capable of peak output currents up to ±3.5A and operating voltages up to 40V.

A low-power standby mode is provided which shuts down internal circuitry to achieve a very low quiescent current draw.

The G2057 device features an adjustable PWM current limit at VSEN pin. And G2057A provided a fixed current limit 0.35V.

Internal protection functions are provided for undervoltage(UVLO), overcurrent(OCP), short-to-supply, short-to-ground, and overtemperature(OTS). Fault conditions are indicated through the nFAULT pin.

The G2057 and G2057A are both packaged in SOP-8 (FD)package.

Ordering Information

ORDER NUMBER	MARKING	TEMP. RANGE	PACKAGE (Green)
G2057F11U	G2057	-40°C to +85°C	SOP-8 (FD)
G2057AF11U	G2057A	-40°C to +85°C	SOP-8 (FD)

Note: F1: SOP-8-EP

1 : Bonding Code

U : Tape & Reel

Green : Lead Free / Halogen Free.

Pin Configuration

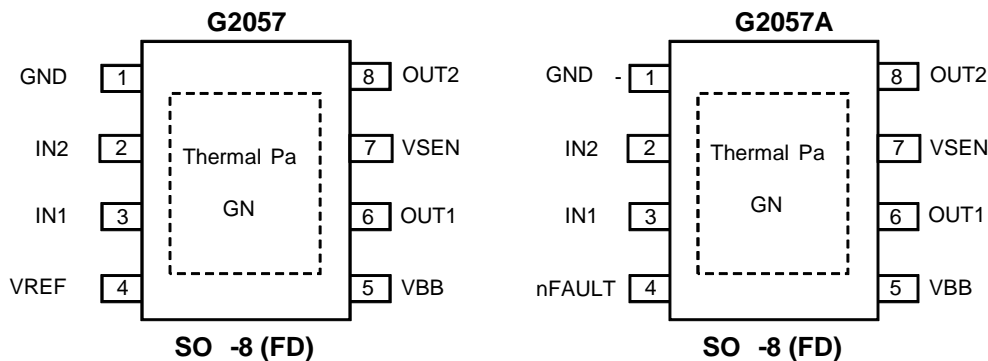

Note: Recommend connecting the Thermal Pad to the Ground for excellent power dissipation.

Absolute Maximum Ratings

Load supply voltage⁽²⁾ (VBB) -0.3V to +40V
 Output current (VBB) -3.5V to +3.5V
 Sense voltage (V_{SENSE}) -500mV to +500mV
 VBB to OUTx (V_{SENSE}) 42V
 OUTx to SENSE (V_{SENSE}) 42V
 Logic input voltage⁽²⁾ (VDD) -0.3V to +7V
 Continuous total power dissipation (VDD)
 See Thermal Information
 Thermal Resistance Junction to Ambient, (θ_{JA})
 SOP-8 (FD) TBD°C/W
 Continuous Power Dissipation ($T_A = +25^\circ\text{C}$)
 SOP-8 (FD) TBW

Thermal Resistance Junction to Case, (θ_{JC})
 SOP-8 (FD) TBD°C/W
 Operating free-air temperature (T_A) . . . -40°C to 85°C
 Maximum junction temperature (T_J) 150°C
 Storage temperature (T_{stg}) -40°C to 125°C
 Reflow Temperature (soldeing, 10 sec) 260°C
 ESD(HBM) $\pm 2000\text{V}$
 ESD(MM) $\pm 200\text{V}$

Recommended Operating Conditions

Input voltage, VBB (V_{IN}) +8V to +40V
 Operating free-air temperature (T_A) . . . -40°C to 85°C

- (1) Stress beyond those listed under "Absolute Maximum Ratings" may cause permanent damage to the device. These are stress ratings only, and functional operation of the device at these or any other conditions beyond those indicated under Recommended Operating Conditions is not implied. Exposure to absolute-maximum-rated conditions for extended periods may affect device reliability.
- (2) All voltage values are with respect to network ground terminal.

Electrical Characteristics

The device is not guaranteed to function outside its operating conditions. Parameters with MIN and/or MAX limits are 100% tested at +25°C, unless otherwise specified.

PARAMETER	SYMBOL	CONDITIONS	MIN	TYP	MAX	UNITS
Load Supply Voltage Range	VBB		6.5	---	40	
Motor supply current	IBB	$f_{PWM} < 30\text{kHz}$	---	10	20	mA
		Low Power Standby mode	---	---	10	μA
Logic Input Voltage Range	V_{IH}		2	---	---	V
	V_{IL}		---	---	0.8	
Logic input current	I_{IH}	$V_{IN}=2\text{V}$	---	40	100	μA
	I_{IL}	$V_{IN}=0.8\text{V}$	---	16	40	
nFAULT output voltage	V_{OL}	$I_{SINK}=5\text{mA}$	---	---	0.5	V
nFAULT high leakage current	IO	$V_O=3.3\text{V}$	---	---	1	μA
Output ON-resistance	$r_{DS(on)}$	Source driver, $I_{OUT}=-2.5\text{A}$, $T_J=25^\circ\text{C}$	---	307	---	m Ω
		Source driver, $I_{OUT}=2.5\text{A}$, $T_J=125^\circ\text{C}$	---	650	TBD	
		Sink driver, $I_{OUT}=2.5\text{A}$, $T_J=25^\circ\text{C}$	---	258	---	
		Sink driver, $I_{OUT}=2.5\text{A}$, $T_J=125^\circ\text{C}$	---	550	TBD	
RSEN voltage trip(G2057A)	VTRP	VSEN connected to ground through a RSEN resistor	---	350	---	mV
Body diode forward voltage	V_f	Source diode, $I_f=-2.5\text{A}$	---	---	1.5	V
		Sink diode, $I_f=2.5\text{A}$	---	---	1.5	
Crossover delay	t_{COD}		---	500	---	ns
VREF Input Voltage Range(G2057)	VREF		0	---	5	V
Current gain(G2057)	A_v	$V_{REF}/V_{SEN}, V_{REF}=5\text{V}$	9.5	---	10.5	V/V
		$V_{REF}/V_{SEN}, V_{REF}=2.5\text{V}$	9.0	---	10.0	V/V
		$V_{REF}/V_{SEN}, V_{REF}=1\text{V}$	8.5	---	10.0	V/V
Blank Time	T_{blank}		2	3	4	μs
Constant off-time	T_{off}		16	25	34	μs
Standby Timer	tst	Inputs low to sleep	---	1	1.5	ms
Power-up Delay	tpu		---	40	50	μs
Overcurrent protection trip level	IOCP		3.7	4.5	6.4	A
Overcurrent deglitch time	$T_{dg,ocp}$		---	3	---	μs
Overcurrent retry time(G2057A)	T_{retry}		---	3	---	ms

Electrical Characteristics (Continued)

PARAMETER	SYMBOL	CONDITIONS	MIN	TYP	MAX	UNITS
PROTECTION CIRCUITRY						
UVLO threshold	VUV	VBB increasing	---	6.3	6.5	V
Overcurrent threshold	I _{OC} P		3.7	4.5	6.4	A
Overcurrent deglitch time	t _{DEG}		---	3	---	μs
Overcurrent retry time(G2057A)	t _{OC} P		---	3	---	ms
Thermal shutdown temperature	TJTSD	Temperature increasing ⁽²⁾	---	155	---	°C

Minimum Footprint PCB Layout Section

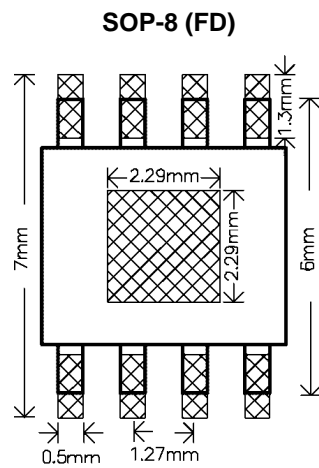

Pin Descriptions

PIN		NAME	I/O	DESCRIPTION
G2057	G2057A			
(1)	4	nFAULT	O	Pulled logic low in FAULT condition. Open-drain output requires external pullup.
2	2	IN2	I	Logic input 2
3	3	IN1	I	Logic input 1
4	-	VREF	I	Analog input
5	5	VBB	P	Connect to motor power supply. Bypass to ground with 0.1 μ F ceramic capacitor and appropriate bulk capacitance rated for VBB.
6	6	OUT1	O	H-bridge output 1. Connect directly to motor terminal 1.
7	7	VSEN	P	High current ground path – sense resistor connection
8	8	OUT2	P	H-bridge output 1. Connect directly to motor terminal 2.
-	1	GND-	P	Connect to board ground
EP	EP	GND	P	Exposed pad for thermal dissipation. Must be connect to board ground.

Parameter Measurement Information

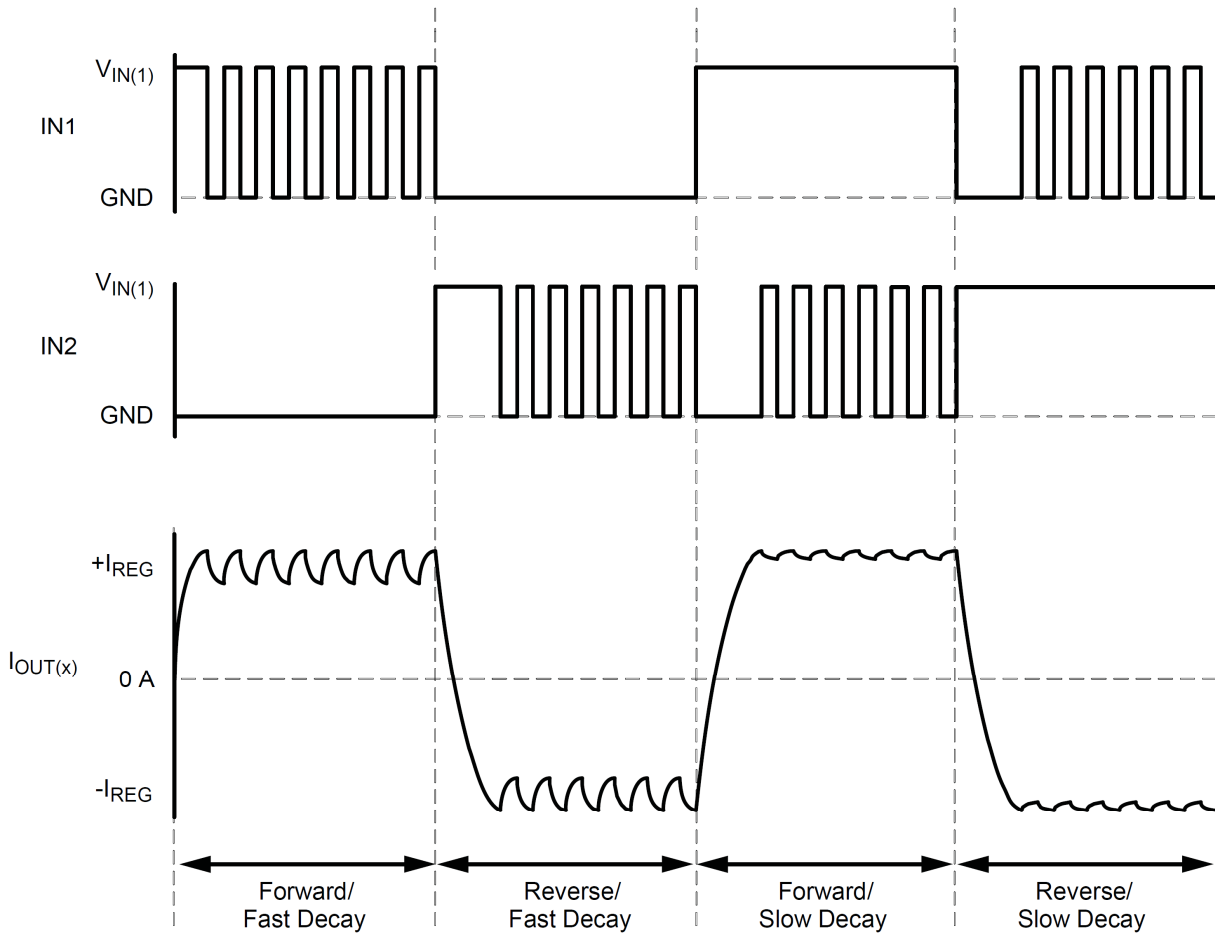

Figure 1. PWM Control Timing

Detailed Description

Over view

The G2057 devices are integrated motor driver solutions for brushed DC motors. The devices integrate four N-channel MOSFETs, protection circuitry, and simple digital interface. The devices can be powered with a supply voltage between 6.5 and 40V and are capable of providing an output current up to 3.5A.

Two logic inputs control the H-bridge driver, which consists of four N-channel MOSFETs that have a typical $R_{ds(on)}$ of $600m\Omega$ (including one high-side and one low-side FET). The integrated charge pump of the device boosts V_{BB} internally and fully enhances the high-side FETs. Motor speed can be controlled with pulse-width modulation. The device has an integrated sleep mode that is entered by bringing both inputs low. An assortment of protection features prevent the device from being damaged if a system fault occurs.

Functional Block Diagrams

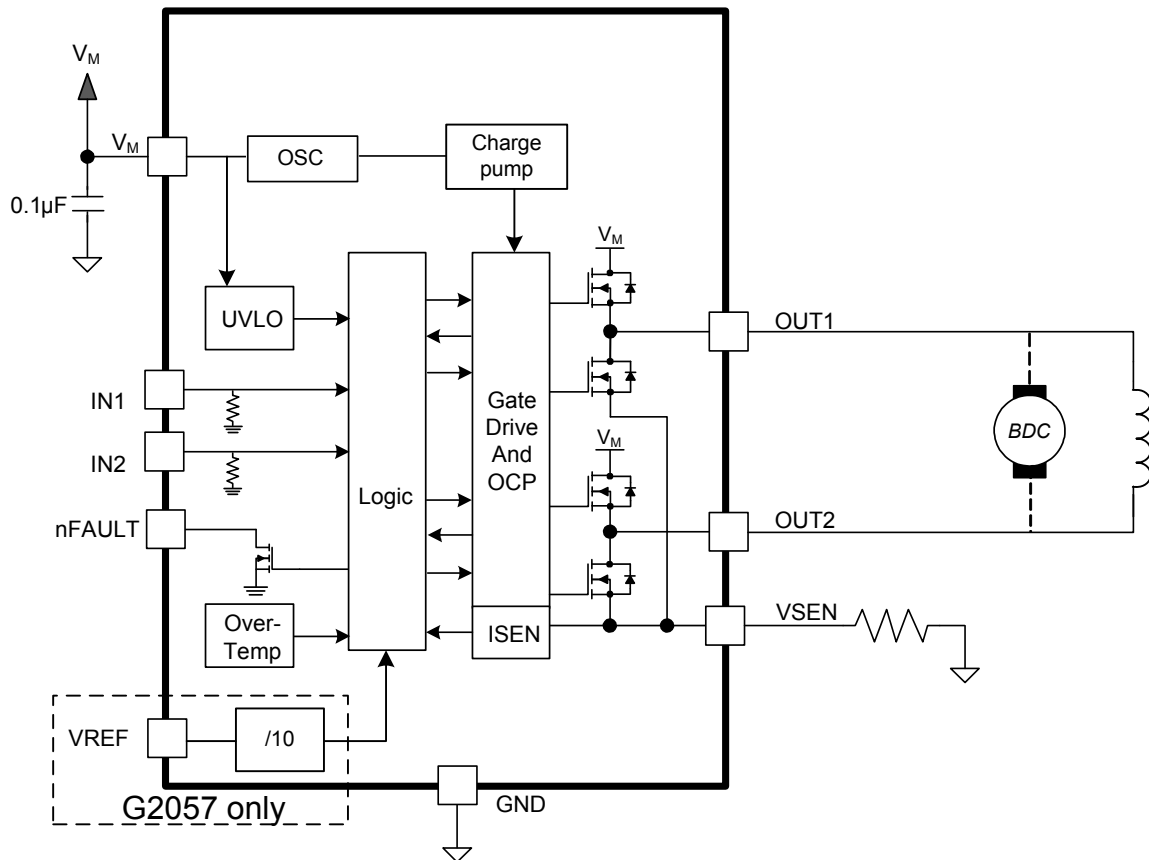

Figure 3. Functional Block Diagrams

Feature Description

Logic Inputs

We recommend using a high-value pull-up resistor when logic inputs are pulled up to VDD. This resistor limits the current to the input in case an overvoltage event occurs. Logic inputs are IN1 and IN2. Voltages higher than 7V on any logic input can cause damage to the input structure.

Shutdown

As a measure to protect the device, faults caused by very high junction temperatures or Short circuit to VBB/GND on outputs disable the outputs of the device until the fault condition is removed. At power on, the UVLO circuit disables the drivers.

Low-Power Sleep Mode

Low Power Sleep mode is activated when both input (INx) pins are low for longer than 1ms. Low Power Sleep mode disables most of the internal circuitry, including the charge pump and the regulator. When the G2057/G2057A device is coming out of sleep mode, the charge pump should be allowed to reach its regulated voltage(a maximum delay of 200us) before any PWM commands are issued to the device.

Mixed Decay Operation (G2057)

The bridges operate in Mixed Decay mode. Referring to the figure below, as the trip point is reached, the device goes into fast decay mode for 50% of the fixed off-time period. After the fast decay portion the G2057 device switches to slow decay mode for the remainder of the off-time. During transitions from fast decay to slow decay, the drivers are forced off for the Crossover Delay, t_{COD} . This feature is added to prevent shoot-through in the bridge. During this “dead time” portion, synchronous rectification is not active, and the device operates in fast decay and slow decay only.

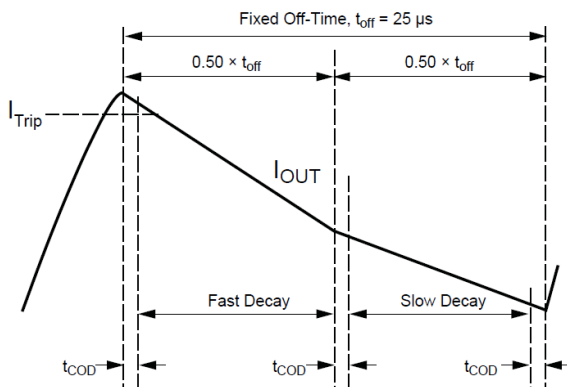

Current regulation

The maximum value of current limiting is set by the selection of R_{sx} and the trip voltage. In G2057, trip voltage is determined by the VREF pin. On the other hand, in G2057A, trip voltage is set as 0.35V. The transconductance function is approximated by the maximum value of current limiting, $I_{TripMAX}$ (A), which is set by:

$$I_{TripMAX} = \frac{V_{trip}}{R_s} = \frac{0.35V}{R_s} \dots G2057A$$

$$= \frac{V_{REF} / 10}{R_s} \dots G2057$$

Where VREF is the input voltage on the VREF pin(V) and R_s is the resistance of the sense resistor on the LS terminal.

Braking

The braking function is implemented by driving the device in slow-decay mode, which is done by applying a logic high to both inputs, after a bridge-enable Chop command (see PWM Control Truth Table). Because it is possible to drive current in both directions through the MOSET switches, this configuration effectively shorts-out the motor-generated BEMF, as long as the Chop command is asserted. The maximum current can be approximated by V_{BEMF}/R_L . Care should be taken to ensure that the maximum ratings of the device are not exceeded in worse-case braking situations: high speed and high-inertia loads.

Diagnostic Output

The nFAULT pin signals a problem with the chip via an open-drain output. A motor fault, undervoltage condition, or $T_j > 155^\circ C$ drives the pin low. This output is not valid when both inputs set low and the device into low power sleep mode. nFAULT is a status-only signal and does not affect any device functionality. The H-bridge portion still operates normally down to $V_{BB}=8V$ with nFAULT asserted.

Thermal Shutdown (TSD)

Two die-temperature monitors are integrated on the chip. As the die temperature increases to approximately $155^\circ C$, this fault drives the nFAULT low and the full-bridge outputs are disabled until the internal temperature falls below a hysteresis of $15^\circ C$.

Table 1. G2057 Control Logic Table⁽¹⁾

PINS					OPERATION
IN1	IN2	10xVS>VREF	OUT+	OUT-	
0	1	False	L	H	Reverse
1	0	False	H	L	Forward
0	1	True	H/L	L	Chop (mixed decay), reverse ⁽²⁾
1	0	True	L	H/L	Chop (mixed decay), forward ⁽²⁾
1	1	False	L	L	Brake(low side slow decay)
0	0	False	Z	Z	Coast, enters sleep mode after 1ms

Table 2. G2057A Control Logic Table

PINS				OPERATION
IN1	IN2	OUT+	OUT-	
0	1	L	H	Reverse
1	0	H	L	Forward
1	1	L	L	Brake(low-side slow decay)
0	0	Z	Z	Coast, enters sleep mode after 1ms

(1) Z=high impedance

(2) To prevent reversal of current during fast-decay synchronous rectification, outputs go to the high-impedance stage as the current approaches 0A.

Overcurrent Protection

The current flowing through the high-side and low-side drivers is monitored to ensure that the motor lead is not shorted to supply or ground. If a short is detected, the full-bridge outputs are turned off, flag nFAULT is driven low. For G2057, the IC is latched and can only be cleared by coming out of sleep mode or by cycling the power to VBB. For G2057A, a 3ms fault timer is started. After this 3ms period, t_{OCP} , the G2057A device is then allowed to follow the input commands and another turn on is attempted (nFAULT becomes high again during this attempt). If there is still a fault condition, the cycle repeats. If after t_{OCP} expires it is determined the short condition is not present, normal operation resumes and nFAULT is deasserted.

VSEN

A low-value resistor can be placed between the VSEN pin and ground for current-sensing purposes. To minimize ground-trace IR drops in sensing the output current level, the current-sensing resistor should have an independent ground return to the star ground point. This trace should be as short as possible. For low-value sense resistors, the IR drops in the PCB can be significant, and should be taken into account.

$$P_D = I^2 (2 \cdot r_{DS(on) \text{ Sink}}) \quad (1)$$

Note: When selecting a value for the sense resistor, SENSE does not exceed the maximum voltage of $\pm 500\text{mV}$. The H-bridge is disabled and enters recirculation when any current in the motor windings generates a SENSE voltage greater than or equal to 500mV.

Package Information

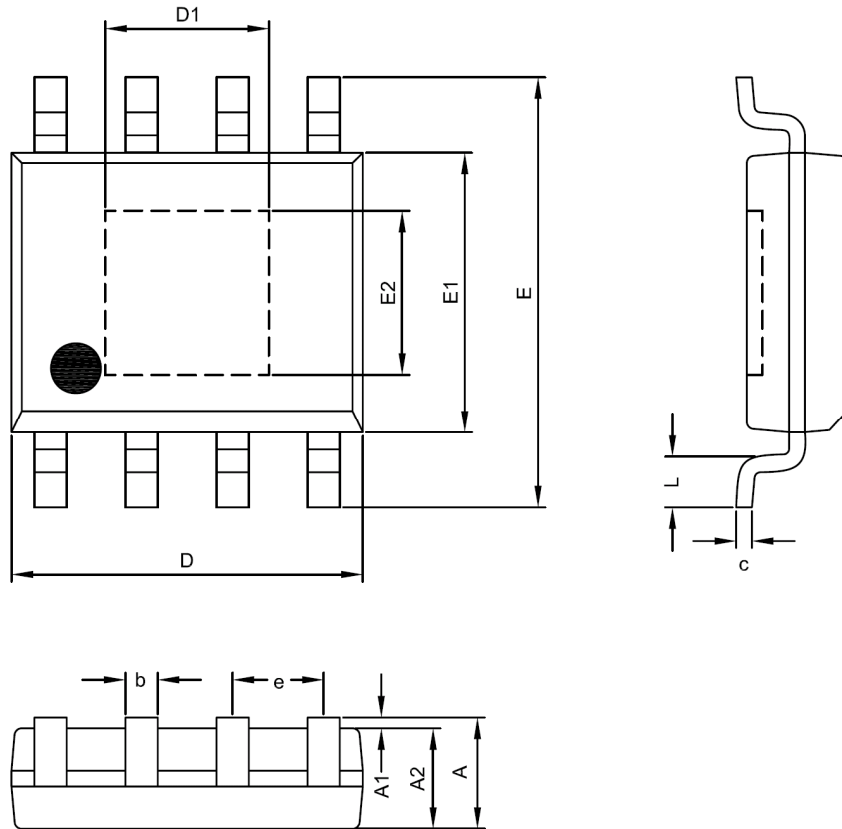

SOP-8 (FD) Package

Symbol	DIMENSION IN MM			DIMENSION IN INCH		
	MIN.	NOM.	MAX.	MIN.	NOM.	MAX.
A	1.35	1.55	1.70	0.053	0.061	0.067
A1	0.00	---	0.10	0.000	---	0.004
A2	1.15	1.35	1.60	0.045	0.053	0.063
D	4.80	4.90	5.00	0.189	0.192	0.197
D1	2.29 BSC			0.090 BSC		
E	5.80	6.00	6.20	0.228	0.236	0.244
E1	3.80	3.90	4.00	0.150	0.153	0.157
E2	2.29 BSC			0.090 BSC		
c	0.20 REF			0.008 REF		
b	0.33	0.43	0.53	0.013	0.017	0.021
e	1.27 BSC			0.050 BSC		
L	0.40	0.70	1.27	0.016	0.028	0.050

Taping Specification

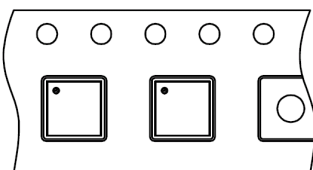

Feed Direction

PACKAGE	Q'TY/REEL
SOP-8 (FD)	2,500 ea

GMT Inc. does not assume any responsibility for use of any circuitry described, no circuit patent licenses are implied and GMT Inc. reserves the right at any time without notice to change said circuitry and specifications.