

Mar.1.2020 Copyright 2020 HIROSE ELECTRIC CO., LTD. All Rights Reserved.  
In case of consideration for using Automotive equipment / device which demand high reliability, kindly contact our sales window correspondents.

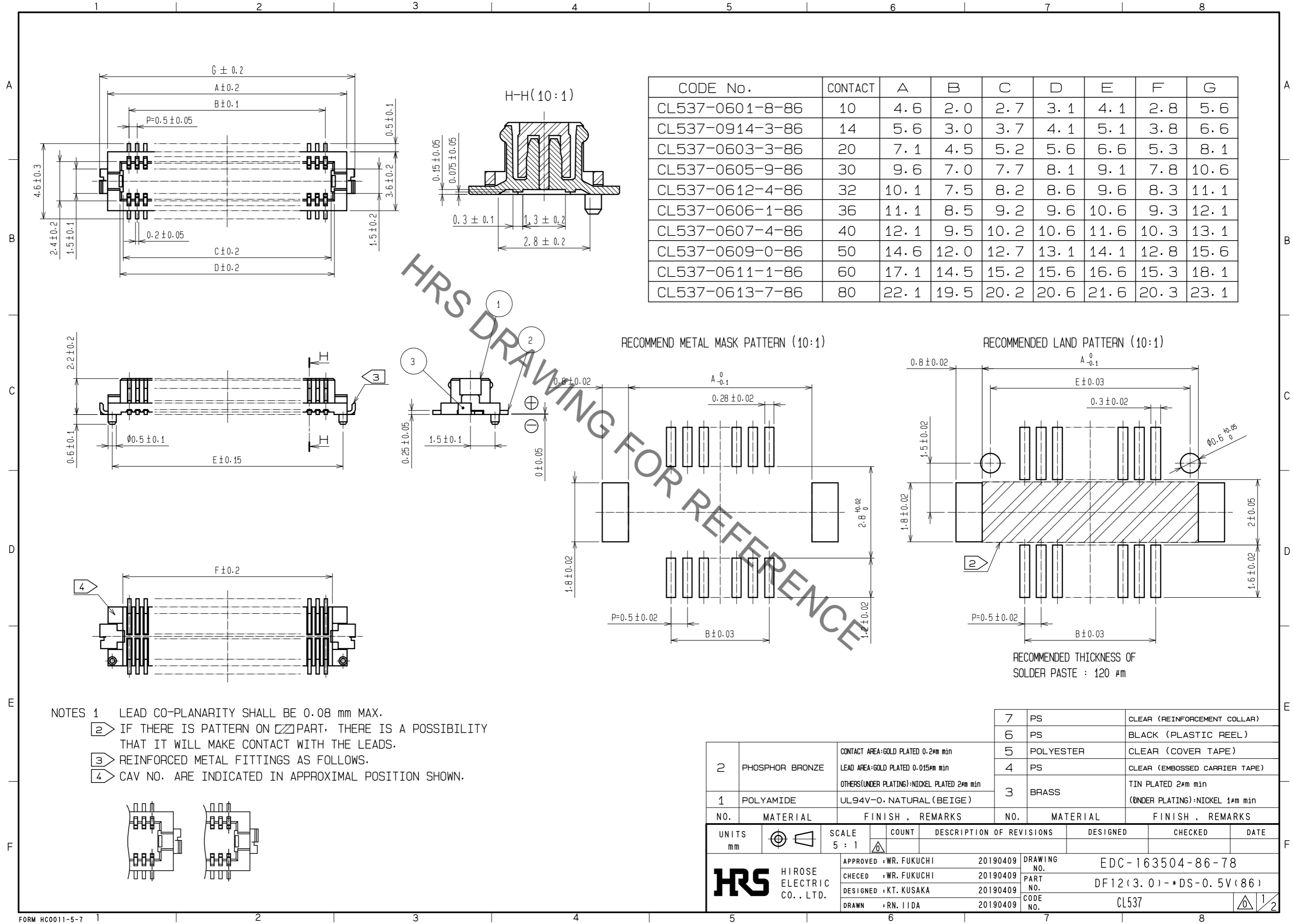

CODE No.	CONTACT	A	B	C	D	E	F	G
CL537-0601-8-86	10	4.6	2.0	2.7	3.1	4.1	2.8	5.6
CL537-0914-3-86	14	5.6	3.0	3.7	4.1	5.1	3.8	6.6
CL537-0603-3-86	20	7.1	4.5	5.2	5.6	6.6	5.3	8.1
CL537-0605-9-86	30	9.6	7.0	7.7	8.1	9.1	7.8	10.6
CL537-0612-4-86	32	10.1	7.5	8.2	8.6	9.6	8.3	11.1
CL537-0606-1-86	36	11.1	8.5	9.2	9.6	10.6	9.3	12.1
CL537-0607-4-86	40	12.1	9.5	10.2	10.6	11.6	10.3	13.1
CL537-0609-0-86	50	14.6	12.0	12.7	13.1	14.1	12.8	15.6
CL537-0611-1-86	60	17.1	14.5	15.2	15.6	16.6	15.3	18.1
CL537-0613-7-86	80	22.1	19.5	20.2	20.6	21.6	20.3	23.1

RECOMMEND METAL MASK PATTERN (10:1)

RECOMMENDED LAND PATTERN (10:1)

RECOMMENDED THICKNESS OF SOLDER PASTE : 120 μm

- NOTES
- 1 LEAD CO-PLANARITY SHALL BE 0.08 mm MAX.
  - 2 IF THERE IS PATTERN ON PART, THERE IS A POSSIBILITY THAT IT WILL MAKE CONTACT WITH THE LEADS.
  - 3 REINFORCED METAL FITTINGS AS FOLLOWS.
  - 4 CAV NO. ARE INDICATED IN APPROXIMAL POSITION SHOWN.

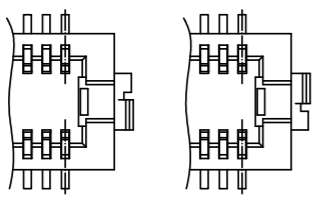

NO.	MATERIAL	FINISH .	REMARKS	NO.	MATERIAL	FINISH .	REMARKS
2	PHOSPHOR BRONZE		CONTACT AREA:GOLD PLATED 0.2μm min LEAD AREA:GOLD PLATED 0.015μm min OTHERS(UNDER PLATING):NICKEL PLATED 2μm min	7	PS		CLEAR (REINFORCEMENT COLLAR)
1	POLYAMIDE		UL94V-0, NATURAL (BEIGE)	6	PS		BLACK (PLASTIC REEL)
				5	POLYESTER		CLEAR (COVER TAPE)
				4	PS		CLEAR (EMBOSSED CARRIER TAPE)
				3	BRASS		TIN PLATED 2μm min (UNDER PLATING):NICKEL 1μm min

  

UNITS	SCALE	COUNT	DESCRIPTION OF REVISIONS	DESIGNED	CHECKED	DATE
mm	5 : 1	△				

  

APPROVED	: WR. FUKUCHI	20190409	DRAWING NO.	EDC-163504-86-78
CHECED	: WR. FUKUCHI	20190409	PART NO.	DF12(3.0)-*DS-0.5V(86)
DESIGNED	: KT. KUSAKA	20190409	CODE NO.	CL537
DRAWN	: RN. IIDA	20190409		

Mar.1.2020 Copyright 2020 HIROSE ELECTRIC CO., LTD. All Rights Reserved.  
 In case of consideration for using Automotive equipment / device which demand high reliability, kindly contact our sales window correspondents.

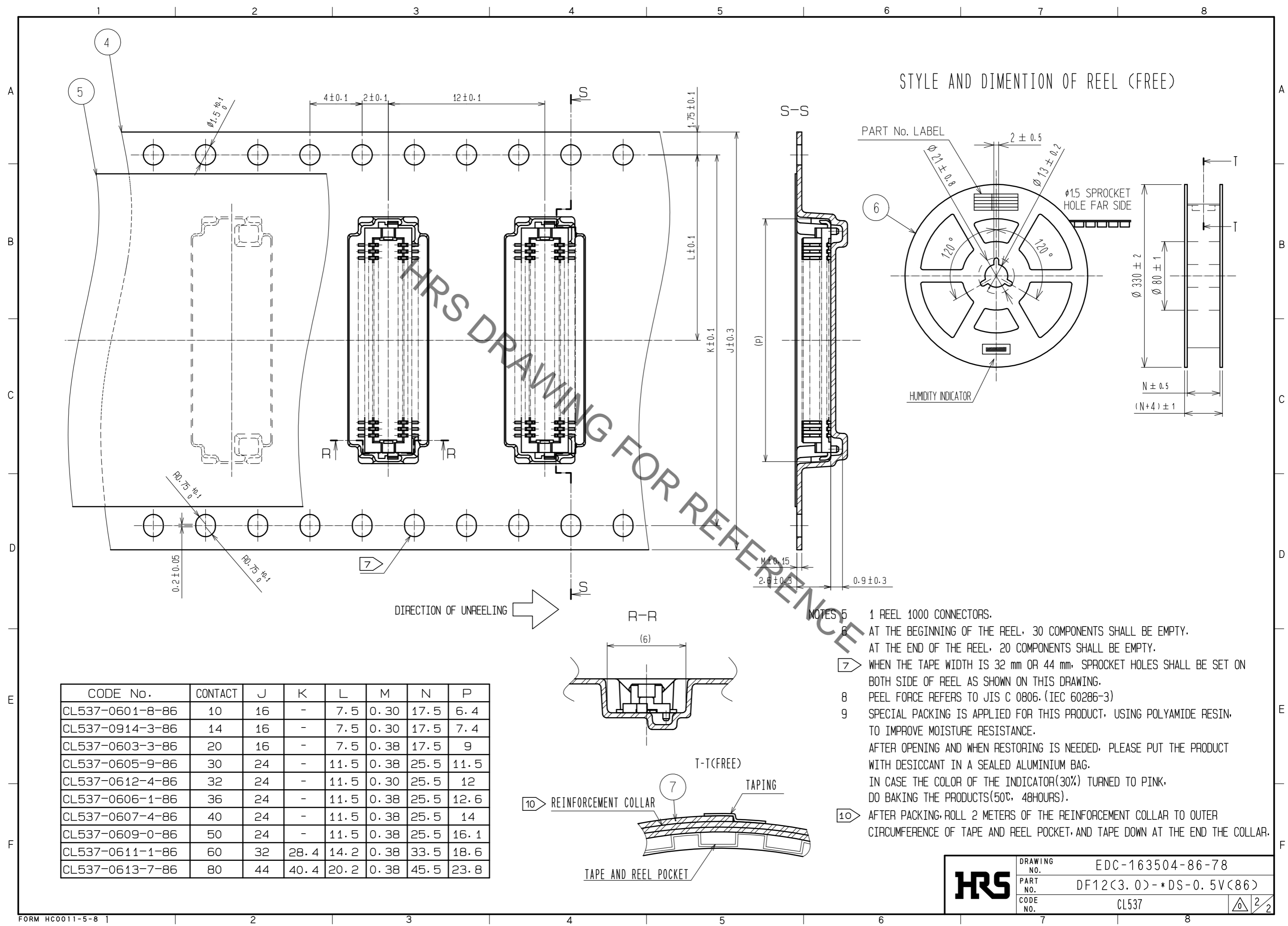

STYLE AND DIMENTION OF REEL (FREE)

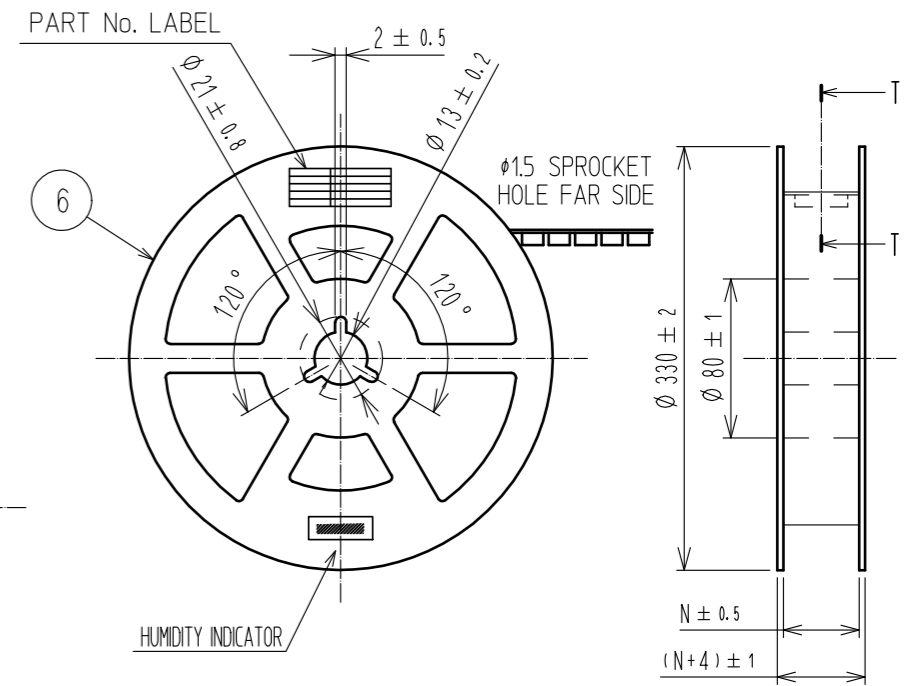

DIRECTION OF UNREELING →

CODE No.	CONTACT	J	K	L	M	N	P
CL537-0601-8-86	10	16	-	7.5	0.30	17.5	6.4
CL537-0914-3-86	14	16	-	7.5	0.30	17.5	7.4
CL537-0603-3-86	20	16	-	7.5	0.38	17.5	9
CL537-0605-9-86	30	24	-	11.5	0.38	25.5	11.5
CL537-0612-4-86	32	24	-	11.5	0.30	25.5	12
CL537-0606-1-86	36	24	-	11.5	0.38	25.5	12.6
CL537-0607-4-86	40	24	-	11.5	0.38	25.5	14
CL537-0609-0-86	50	24	-	11.5	0.38	25.5	16.1
CL537-0611-1-86	60	32	28.4	14.2	0.38	33.5	18.6
CL537-0613-7-86	80	44	40.4	20.2	0.38	45.5	23.8

- NOTES
- 5 1 REEL 1000 CONNECTORS.
  - 6 AT THE BEGINNING OF THE REEL, 30 COMPONENTS SHALL BE EMPTY.  
AT THE END OF THE REEL, 20 COMPONENTS SHALL BE EMPTY.
  - 7 WHEN THE TAPE WIDTH IS 32 mm OR 44 mm, SPROCKET HOLES SHALL BE SET ON BOTH SIDE OF REEL AS SHOWN ON THIS DRAWING.
  - 8 PEEL FORCE REFERS TO JIS C 0806. (IEC 60286-3)
  - 9 SPECIAL PACKING IS APPLIED FOR THIS PRODUCT, USING POLYAMIDE RESIN, TO IMPROVE MOISTURE RESISTANCE.  
AFTER OPENING AND WHEN RESTORING IS NEEDED, PLEASE PUT THE PRODUCT WITH DESICCANT IN A SEALED ALUMINIUM BAG.  
IN CASE THE COLOR OF THE INDICATOR(30%) TURNED TO PINK, DO BAKING THE PRODUCTS(50°C, 48HOURS).
  - 10 AFTER PACKING, ROLL 2 METERS OF THE REINFORCEMENT COLLAR TO OUTER CIRCUMFERENCE OF TAPE AND REEL POCKET, AND TAPE DOWN AT THE END THE COLLAR.

<b>HRS</b>	DRAWING NO.	EDC-163504-86-78
	PART NO.	DF12(3.0)-*DS-0.5V(86)
	CODE NO.	CL537