

Description

The SD5087 is 300mA low dropout linear regulator optimized to provide a high performance solution to low power system.

The device offers a new level of cost-effective performance in cellular phones, laptop and notebook computers, and other portable devices. Proprietary design techniques ensure high performance.

The SD5087 is designed to make use of low cost ceramic capacitors which ensure the stability of the output current, and enhance the efficiency in order to prolong the battery life of those portable devices.

The SD5087 regulators are available in the industry standard SOT-23-5/ SC70-5/ DFN1.2*1.6-4L/ DFN2*2-6L power packages (or upon request).

Feature

- Input Voltage: 1.8V ~ 5.5V
- 0.47 μ F~10 μ F Ceramic Capacitors Ensure the Stability
- 300mA Maximum Output Current
- Low Quiescent Current: 60 μ A
- Shut-down Current: < 0.1 μ A
- Overload/Over Temperature Protection
- Specified from: -45 $^{\circ}$ C ~ +80 $^{\circ}$ C

Application

- Laptop/notebook/palmtop computers
- Portable devices
- Disk driver
- Battery chargers
- Bluetooth and other radio products
- MP3/MP4 Players
- Cellular phones, radiophone, digital cameras, and portable electronics

Order Information

SD5087- ① ②:

SYMBOL	DESCRIPTION (SOT)
①	Denotes Output Voltage: K: 1.2V I: 1.3V B: 1.5V C: 1.8V H: 2.5V E: 2.8V F: 3.0V G: 3.3V
②	Denotes Package Type: B: SOT-353-5(SC70-5) E: SOT-23-5L

SYMBOL	DESCRIPTION (DFN)
①	Denotes Output Voltage: E: 2.8V L:3.1V G: 3.3V
②	Denotes Package Type: D: DFN1.2*1.6-4L K: DFN2*2-6L

Typical Application Circuit

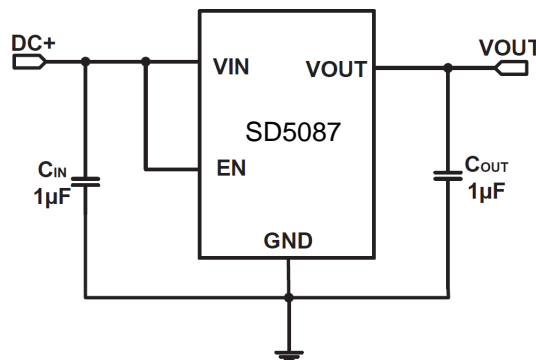

Pin Assignment and Description

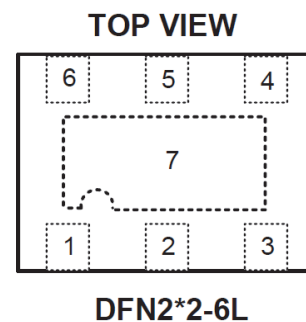
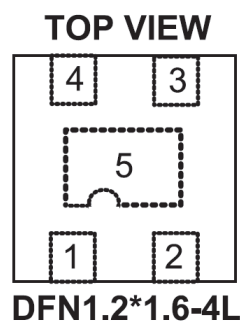
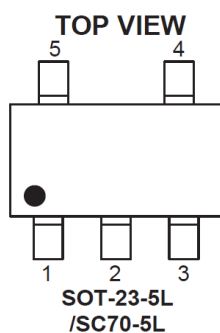

PIN No.			NAME	DESCRIPTION
SOT-23-5L / SC70-5L	DFN1.2*1.6-4L	DFN2*2-6L		
2	2	5, 7	GND	Ground
5	4	4	VOUT	Output Voltage
1	3	3	VIN	Power Supply
3	1	2	EN	ON/OFF Control
4	5	1, 6	NC	No Connect

Absolute Maximum Ratings (Note 1)

- Input Supply, EN Voltage-0.3V ~ 6V
- Power Dissipation, PD @ TA=25°C
 SOT-23-5L0.4W
 SC70-5, DFN1.2*1.6-4L0.3W
 DFN2*2-6L0.5W
- Operating Temperature Range (Note 2).....-45°C ~ +80°C
- Storage Temperature Range..... -65°C ~ +150°C
- Junction Temperature Range.....+125°C
- Lead Temperature (Soldering, 10 sec.)..... +265°C

Note 1: Stresses beyond those listed Absolute Maximum Ratings may cause permanent damage to the device. Exposure to any Absolute Maximum Rating condition for extended periods may affect device reliability and lifetime.

Note 2: The SD5087 is guaranteed to meet performance specifications from 0°C to 70°C. Specifications over the -40°C to 85°C operating temperature range are assured by design, characterization and correlation with statistical process controls.

Electrical Characteristics

Operating Conditions: $T_A=25^{\circ}\text{C}$, $V_{IN}=V_{OUT}+0.5\text{V}$, $C_{IN}=C_{OUT}=1\mu\text{F}$, unless otherwise specified.

SYMBOL	PARAMETER	CONDITIONS	MIN	TYP	MAX	UNITS
V_{IN}	Operating Voltage Range		1.8		5.5	V
ΔV_{OUT}	Output Voltage Accuracy	$I_{OUT} = 10\text{mA}$	-2		+2	%
I_Q	Quiescent Current	$2.2\text{V} \leq V_{IN} \leq 5.5\text{V}$		60		μA
I_{OFF}	Shutdown Current	$V_{EN} = 0\text{V}$, $V_{IN} = 5\text{V}$		0.02		μA
V_{DROP}	Dropout Voltage: $V_{IN} - V_{OUT}$	$I_{OUT} = 150\text{mA}$, $V_{OUT} \leq 1.8\text{V}$ $I_{OUT} = 150\text{mA}$, $V_{OUT} \geq 2.8\text{V}$		150		mV
V_{ENH}	EN Threshold Voltage (High)	$V_{IN} = 5\text{V}$	1.4			V
V_{ENL}	EN Threshold Voltage (Low)				0.8	V
I_{EN}	Enable Pin Current			0.1		μA
I_{LIM}	Current Limited	$V_{IN} = V_{OUT} + 1\text{V}$	330	400	560	mA
PRSS	Power Supply Rejection Rate	$f = 1\text{kHz}$, $I_{OUT} = 100\text{mA}$		-65		dB
ΔV_{LINE}	Line Regulation	$V_{IN} = (V_{OUT} + 0.5)$ to 5.5V , $I_{OUT} = 0\text{mA}$		2		mV
ΔV_{LOAD}	Load Regulation	$0\text{mA} \leq I_{OUT} \leq 100\text{mA}$		10		mV
T_{SD}	Thermal Shutdown Temperature			160		$^{\circ}\text{C}$
ΔT_{SD}	Thermal Shutdown Hysteresis			20		$^{\circ}\text{C}$

Typical Performance Characteristics

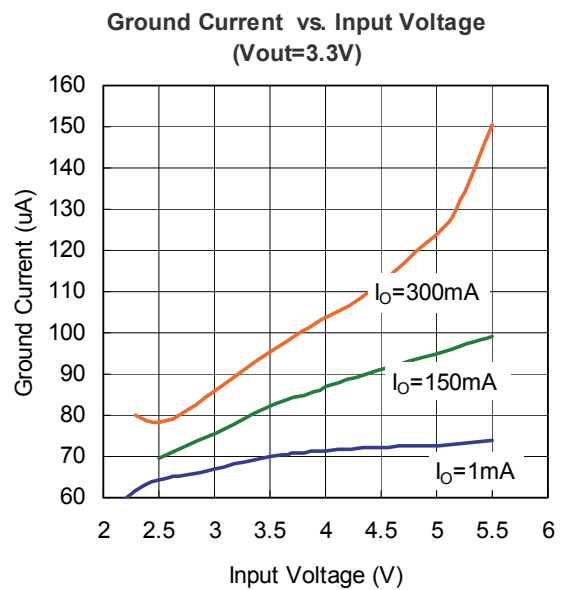
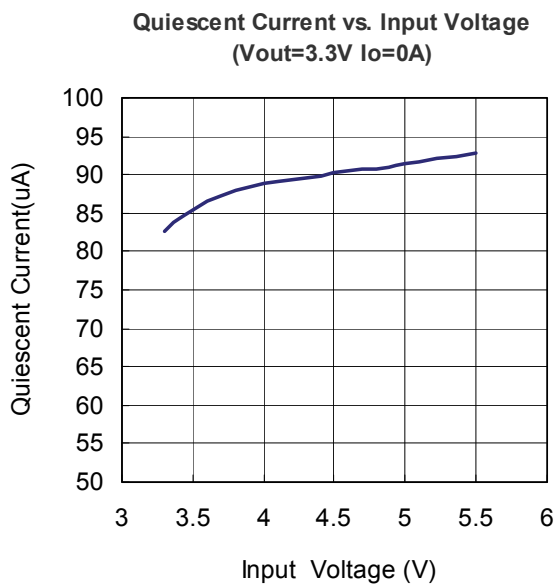
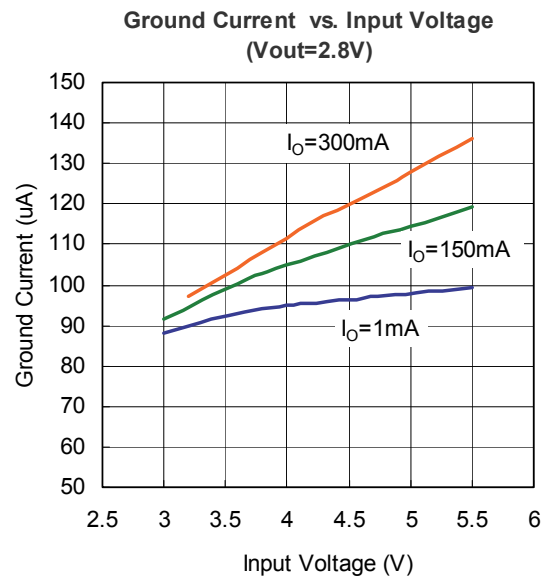
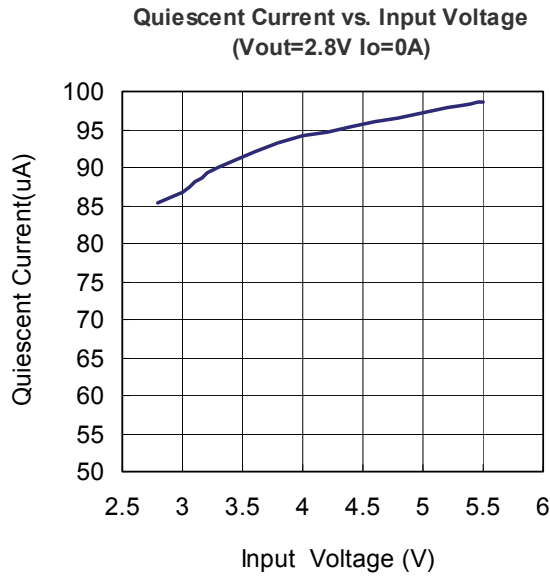
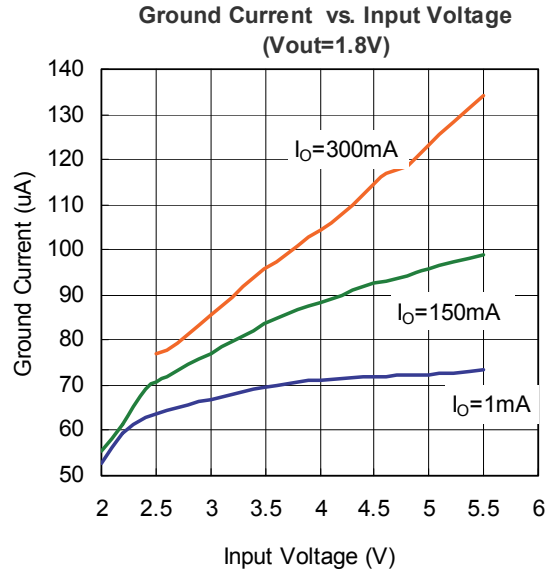
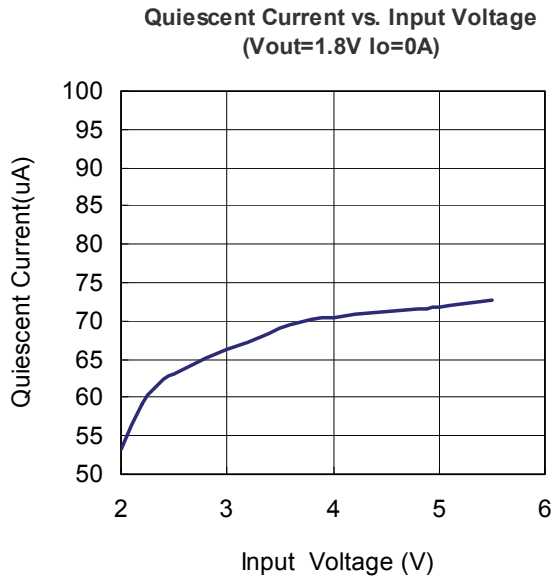

Typical Performance Characteristics(con't)

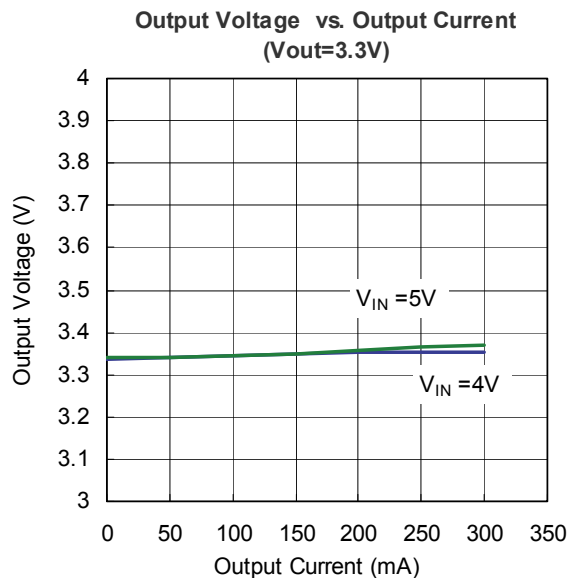
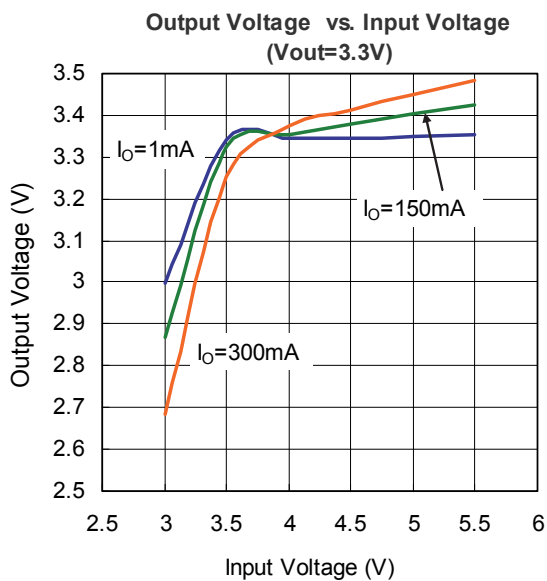
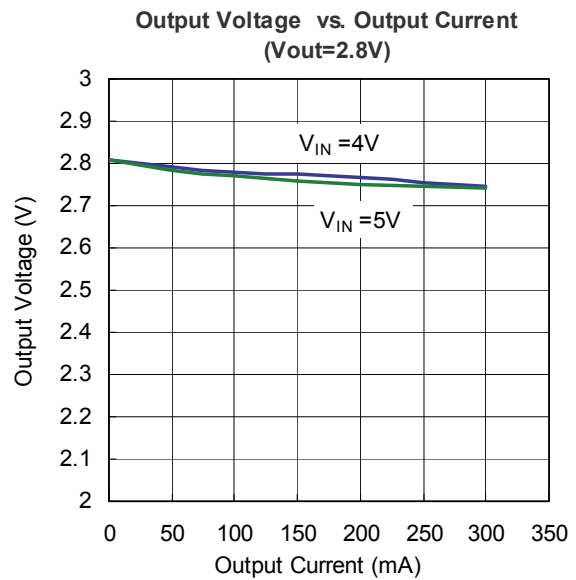
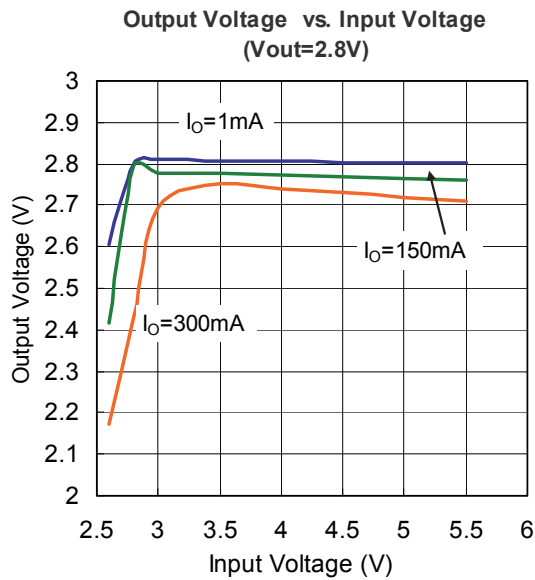
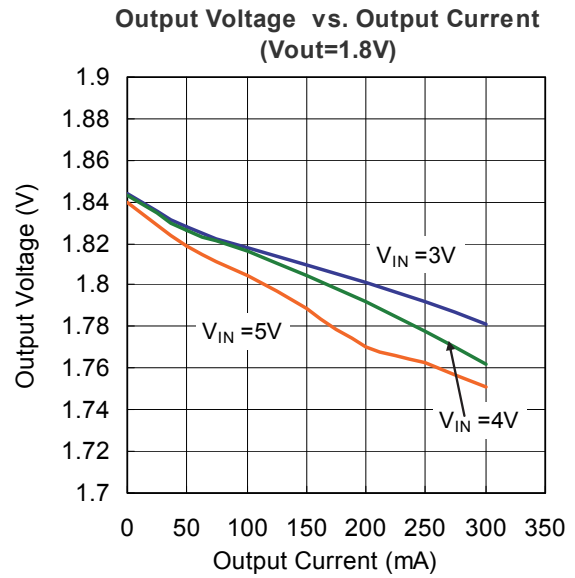
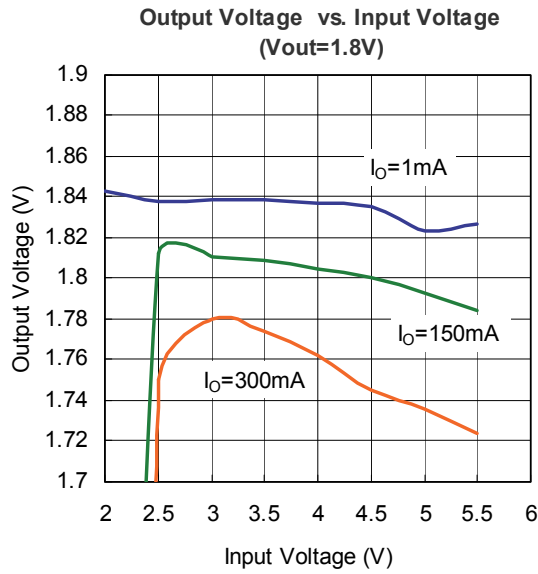

Typical Performance Characteristics(con't)

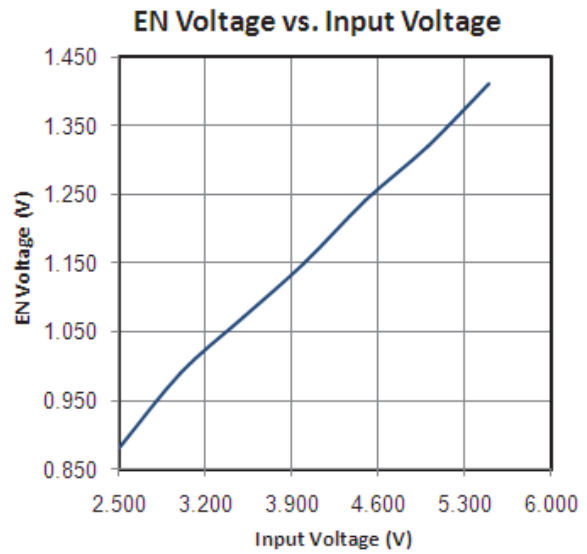
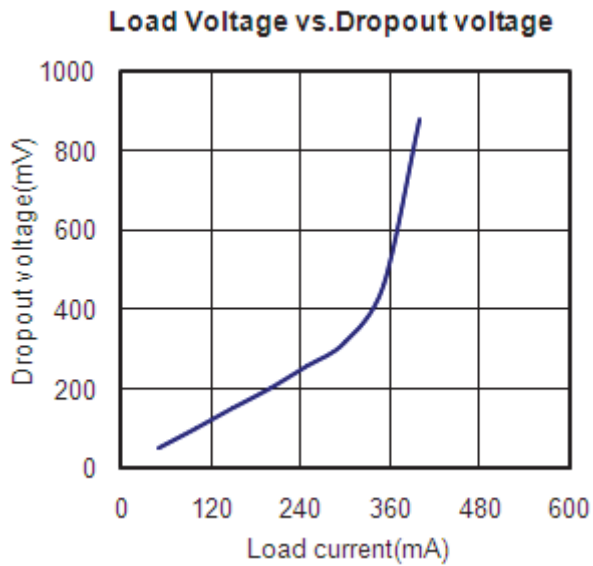

Start Up
($V_{IN} = 3.6V$, $I_{OUT} = 100mA$)

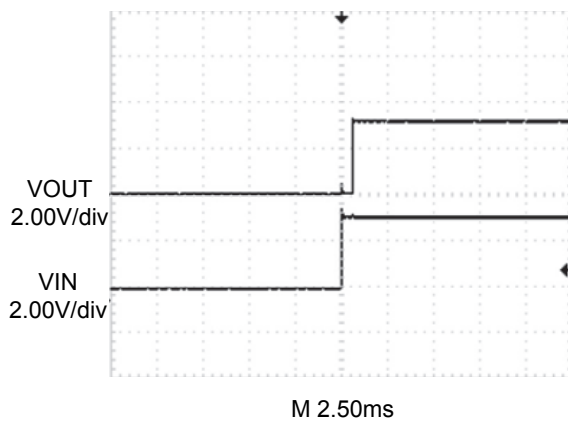

Start Up
($V_{IN} = 3.6V$, $I_{OUT} = 300mA$)

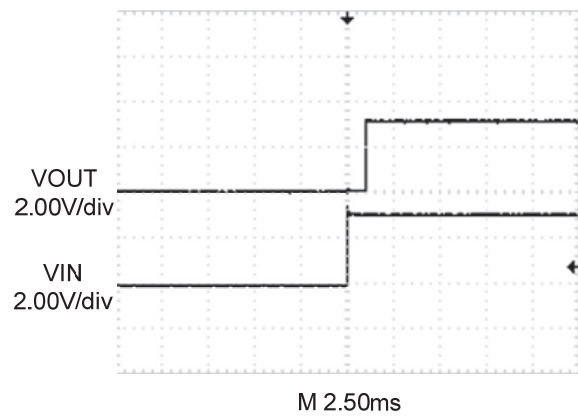

Shut Down
($V_{IN} = 3.6V$, $I_{OUT} = 100mA$)

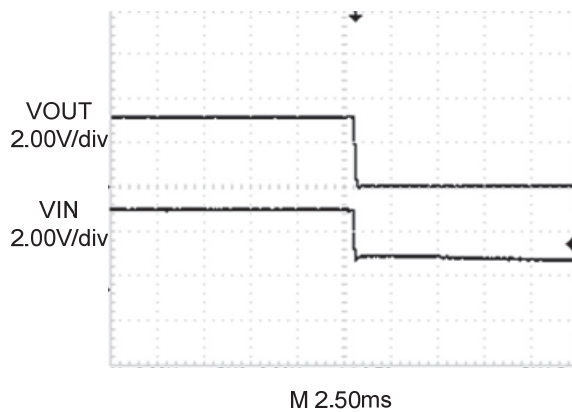

Shut Down
($V_{IN} = 3.6V$, $I_{OUT} = 200mA$)

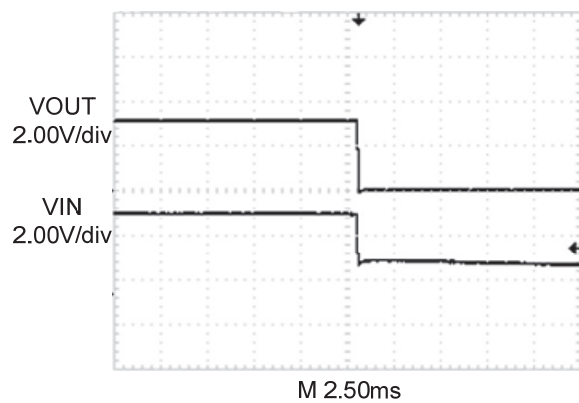

Pin Functions

NC: Not Connect.

EN: ON/OFF Control (High Enable). Forcing this pin above 1.4V enables the part. Forcing this pin below 0.8V can shut down the device. In shutdown, all functions are disabled drawing $<1\mu\text{A}$ supply current. Do not leave EN floating.

VIN: Power Input Voltage. Must be locally bypassed.

VOUT: Output Voltage. It is a fixed output voltage for the Micropower LDO Regulator.

GND: Signal and Power Ground. Provide a short direct PCB path between GND and the (-) side of the output capacitor(s).

Block Diagram

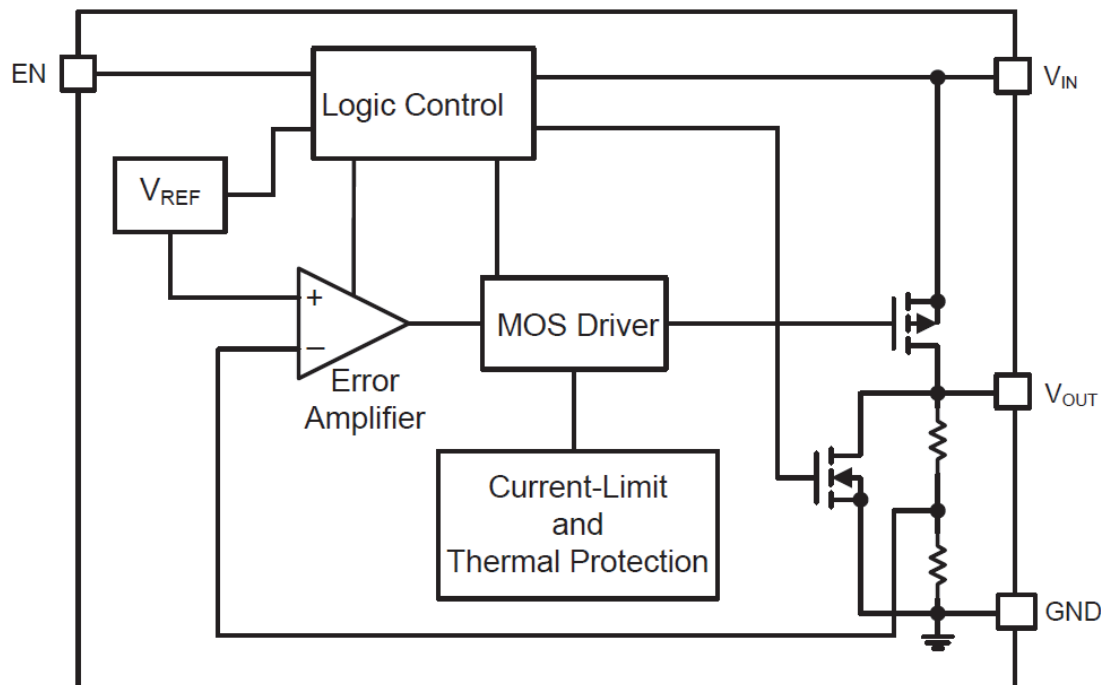

Application Information

Input and Output Capacitor

Like any low dropout regulator, the external capacitors used with the SD5087 must be carefully selected for regulator stability and performance. Using a capacitor whose value is $>1\mu\text{F}$ on the SD5087 input and the amount of capacitance can be increased without limit. The input capacitor must be located a distance of not more than 0.5 inch from the input pin of the IC and returned to a clean analog ground. Any good quality ceramic or tantalum can be used for this capacitor. The capacitor with larger value and lower ESR (equivalent series resistance) provides better PSRR and line-transient response. The output capacitor must meet both requirements for minimum amount of capacitance and ESR in all LDOs application.

The SD5087 is designed specifically to work with low ESR ceramic output capacitor in space-saving and performance consideration. Using a ceramic capacitor whose value is at least $1\mu\text{F}$ with ESR is $> 25\text{m}\Omega$

The SD5087 still works well with output capacitor of other types due to the wide stable ESR range.

Enable Function

The SD5087 features an LDO regulator enable/disable function. To assure the LDO regulator will switch on, the EN turn on control level must be greater than 1volts.

For to protecting the system, the SD5087 have a quick-discharge function. If the enable function is not needed in a specific application, it may be tied to VIN to keep the LDO regulator in a continuously on state.

PSRR

The power supply rejection ratio (PSRR) is defined as the gain from the input to output divided by the gain from the supply to the output. The PSRR is found to be :

$$\text{PSRR} = 20 \times \log \left(\frac{\Delta \text{Gain Error}}{\Delta \text{Supply}} \right)$$

Note that when heavy load measuring, Δsupply will cause $\Delta \text{temperature}$. And $\Delta \text{temperature}$ will cause $\Delta \text{output voltage}$. So the heavy load PSRR measuring must include temperature effect.

Current Limit

The SD5087 contains an independent current limiter, which monitors and controls the pass transistor's gate voltage, limiting the output current to 0.3A (typ.). The output can be shorted to ground indefinitely without damaging the part.

Packaging Information

SOT-23-5L Package Outline Dimension

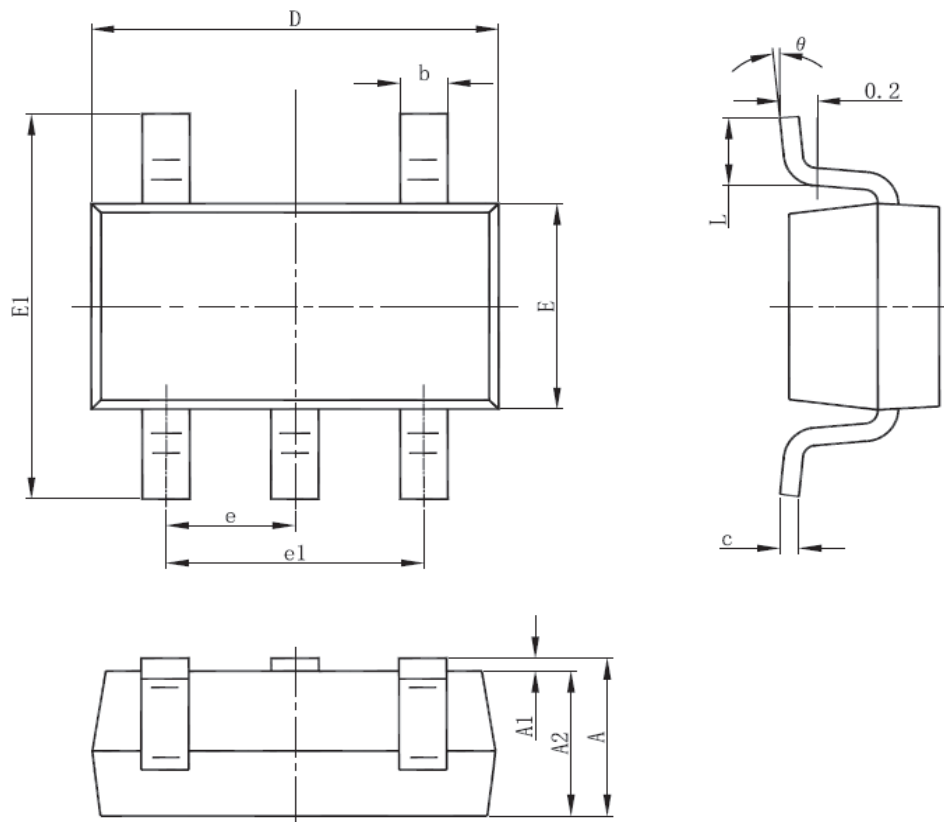

Symbol	Dimensions In Millimeters		Dimensions In Inches	
	Min	Max	Min	Max
A	1.050	1.250	0.041	0.049
A1	0.000	0.100	0.000	0.004
A2	1.050	1.150	0.041	0.045
b	0.300	0.500	0.012	0.020
c	0.100	0.200	0.004	0.008
D	2.820	3.020	0.111	0.119
E	1.500	1.700	0.059	0.067
E1	2.650	2.950	0.104	0.116
e	0.950(BSC)		0.037(BSC)	
e1	1.800	2.000	0.071	0.079
L	0.300	0.600	0.012	0.024
θ	0°	8°	0°	8°

Packaging Information

SC70-5 Package Outline Dimension

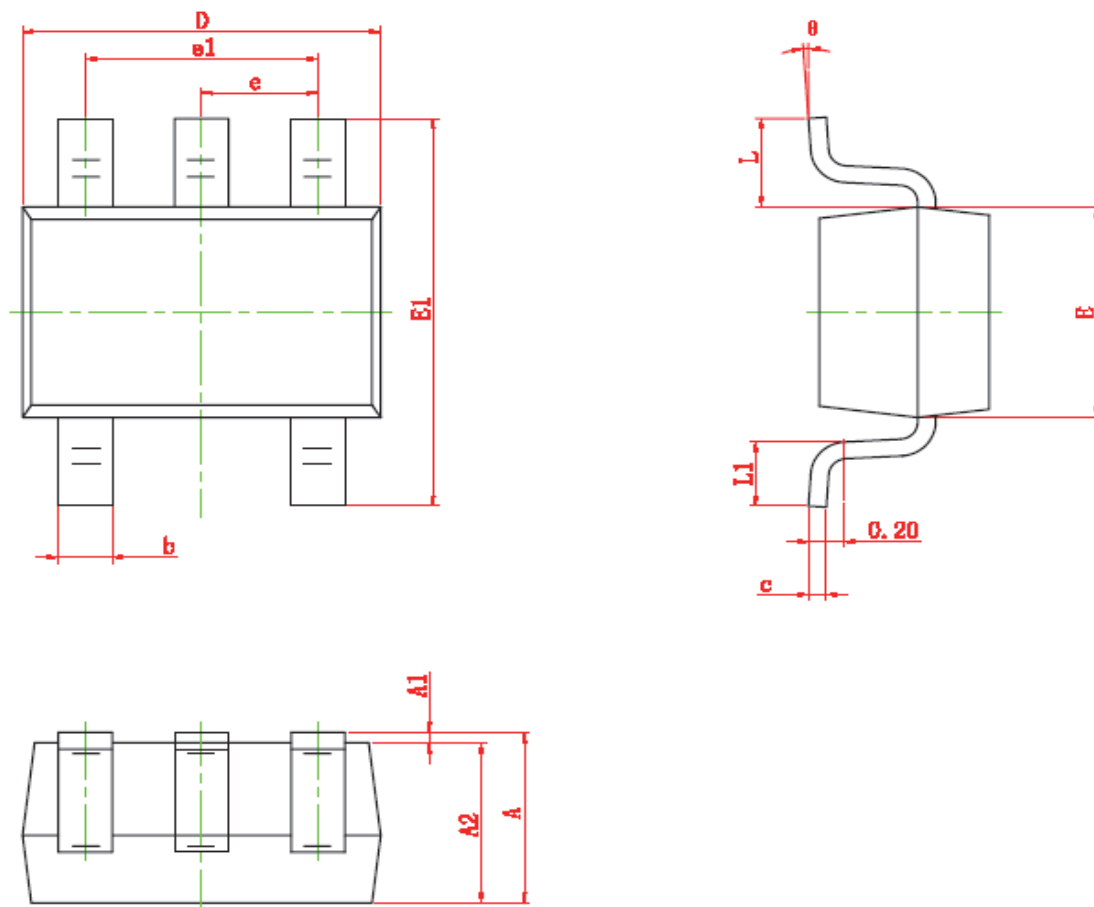

Symbol	Dimensions In Millimeters		Dimensions In Inches	
	Min	Max	Min	Max
A	0.900	1.100	0.035	0.043
A1	0.000	0.100	0.000	0.004
A2	0.900	1.100	0.035	0.039
b	0.150	0.350	0.006	0.014
c	0.080	0.150	0.003	0.006
D	2.000	2.200	0.079	0.087
E	1.150	1.350	0.045	0.053
E1	2.150	2.450	0.085	0.096
e	0.650(BSC)		0.026(BSC)	
e1	1.200	1.400	0.047	0.055
L	0.525 REF		0.021 REF	
L1	0.260	0.460	0.010	0.018
theta	0°	8°	0°	8°

Packaging Information

DFN1.2*1.6-4L Package Outline Dimension

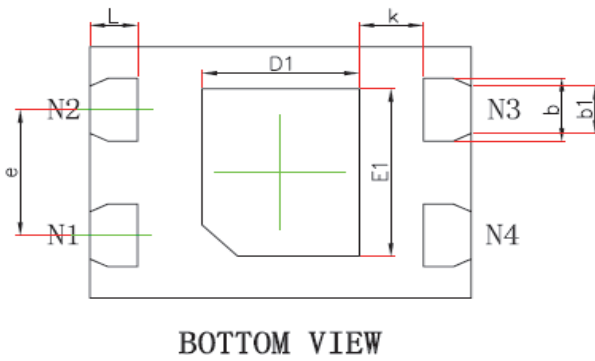
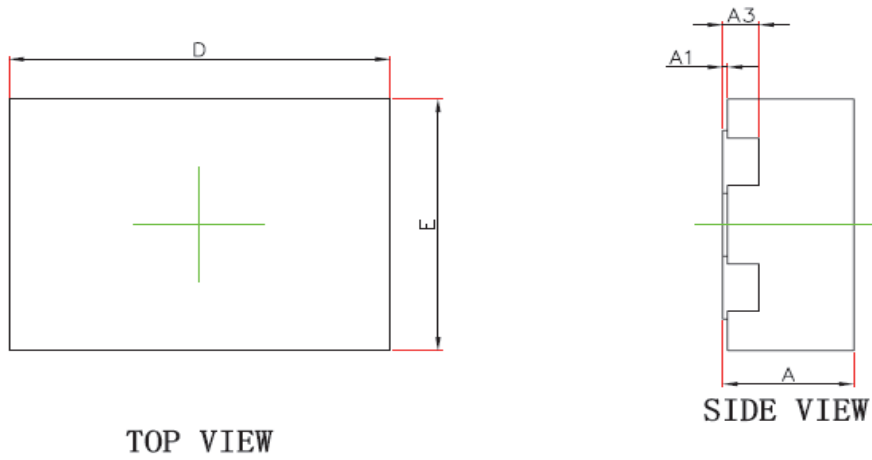

Symbol	Dimensions In Millimeters		Dimensions In Inches	
	Min	Max	Min	Max
A	0.500	0.600	0.020	0.024
A1	0.000	0.050	0.000	0.002
A3	0.152 REF.		0.006 REF.	
D	1.500	1.700	0.059	0.067
E	1.100	1.300	0.043	0.051
D1	0.560	0.760	0.022	0.030
E1	0.700	0.900	0.028	0.035
b	0.250	0.350	0.010	0.014
b1	0.175	0.275	0.007	0.011
e	0.600 TYP.		0.024 TYP.	
L	0.150	0.250	0.006	0.010
k	0.200 MIN.		0.008 TYP.	

Packaging Information

DFN2*2-6L Package Outline Dimension

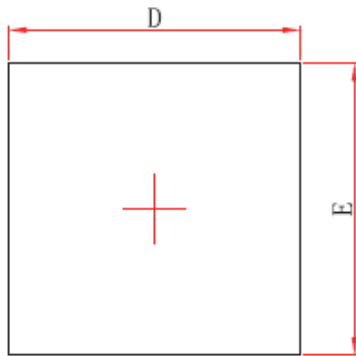
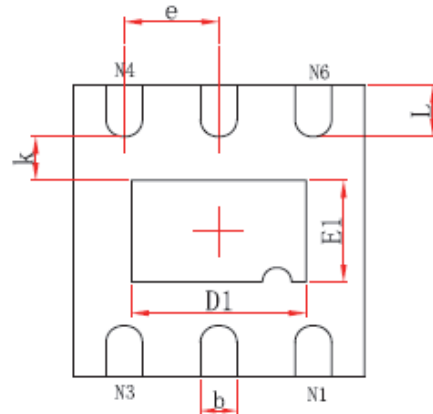
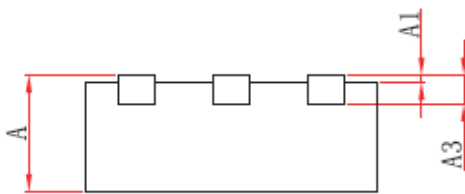
Top View

Bottom View

Side View

Symbol	Dimensions In Millimeters		Dimensions In Inches	
	Min	Max	Min	Max
A	0.700/0.800	0.800/0.900	0.028/0.031	0.031/0.035
A1	0.000	0.050	0.000	0.002
A3	0.203 REF.		0.008 REF.	
D	1.924	2.076	0.076	0.082
E	1.924	2.076	0.075	0.083
D1	1.100	1.300	0.043	0.051
E1	0.600	0.800	0.024	0.031
k	0.200 MIN.		0.008 MIN.	
b	0.200	0.300	0.007	0.012
e	0.650 TYP.		0.026 TYP.	
L	0.274	0.426	0.011	0.017

Shouding reserves the right to update the version of datasheet without notice at any time. Information furnished by Shouding is believed to be accurate and reliable. However, no responsibility is assumed for its use.