



## 1MHz,30V/1.5A High Performance, Boost Converter

### General Description

The LP3317 is a current mode boost DC-DC converter. Its PWM circuitry with built-in 1.5A current power MOSFET makes this converter highly power efficiently. The LP3317 implements a constant frequency 1MHz PWM control scheme. The high frequency PWM operation also saves board space by reducing external component sizes. The LP3317 features automatic shifting to pulse frequency modulation mode at light loads. Highly integration and internal compensation network minimizes as 6 external component counts. Optimized operation frequency can meet the requirement of small LC filters value and low operation current with high efficiency. The LP3317 includes under-voltage lockout, current limiting, and thermal overload protection to prevent damage in the event of an output overload. The LP3317 is available in a small 5-pin SOT23-5 package.

### Order Information

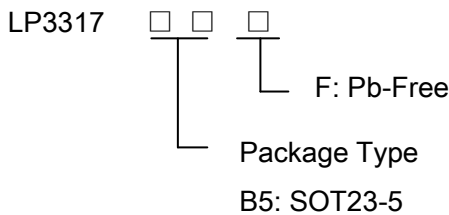

### Applications

- ✧ Panel Bais Voltage supply
- ✧ OLED Backlight driver
- ✧ Notebook Computers
- ✧ Portable Applications
- ✧ MID/PTV

### Features

- ◆ High Efficiency: 90%
- ◆ 1MHzFixed-Frequency PWM Operation
- ◆ Maximum Output Voltage up to 30V
- ◆ Guaranteed 13V/200mA Output with 5V input
- ◆ Operating Range : 2.2V to 5.5V
- ◆ Shutdown Supply Current:<1uA
- ◆ Available in SOT23-5 Package
- ◆ Minimize the External Component
- ◆ RoHS Compliant and 100% Lead (Pb)-Free

### Typical Application Circuit

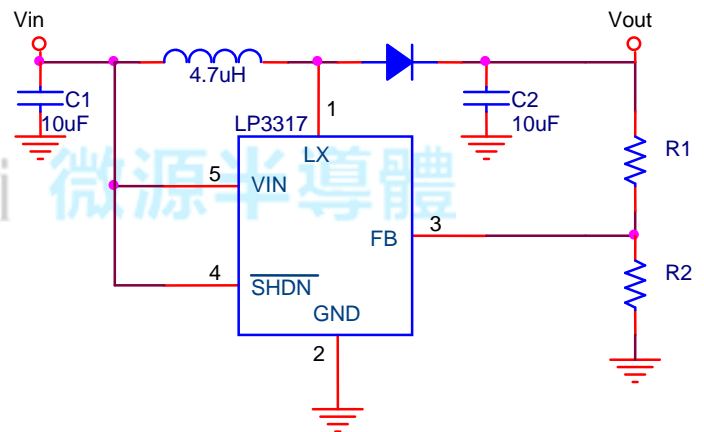

### Marking information

| Device  | Marking | Package | Shipping |
|---|---------|---------|----------|
| LP3317  |         | SOT23-5 | 3K/REEL  |
| Y: Year code. W: Weeks code. X: Series number code. |         |         |          |

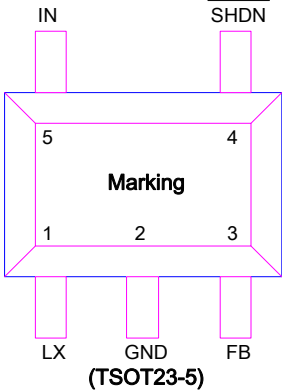

## Functional Pin Description

| Package Type | Pin Configurations   |
|--------------|--|
| SOT23-5      |  <p style="text-align: center;">(TSOT23-5)</p> |

## Pin Description

| Pin | Name  | Description  |
|-----|-------|--|
| 1   | LX    | Switch Pin. Connect this Pin to inductor and catch diode. Minimize the track area to reduce EMI.   |
| 2   | GND   | Ground Pin   |
| 3   | FB    | Feedback Reference Voltage Pin. Series connect a resistor between Vout and ground as a voltage sense.  |
| 4   | /SHDN | Chip Enable (Active High). Voltage sensing input to trigger the function of over voltage protection. Note that this pin is high impedance. There should be a pull low 100kΩ resistor connected to GND when the control signal is floating. |
| 5   | VIN   | Supply Input Voltage Pin. Bypass 10uF capacitor to GND to reduce the input noise.  |



### Function Block Diagram

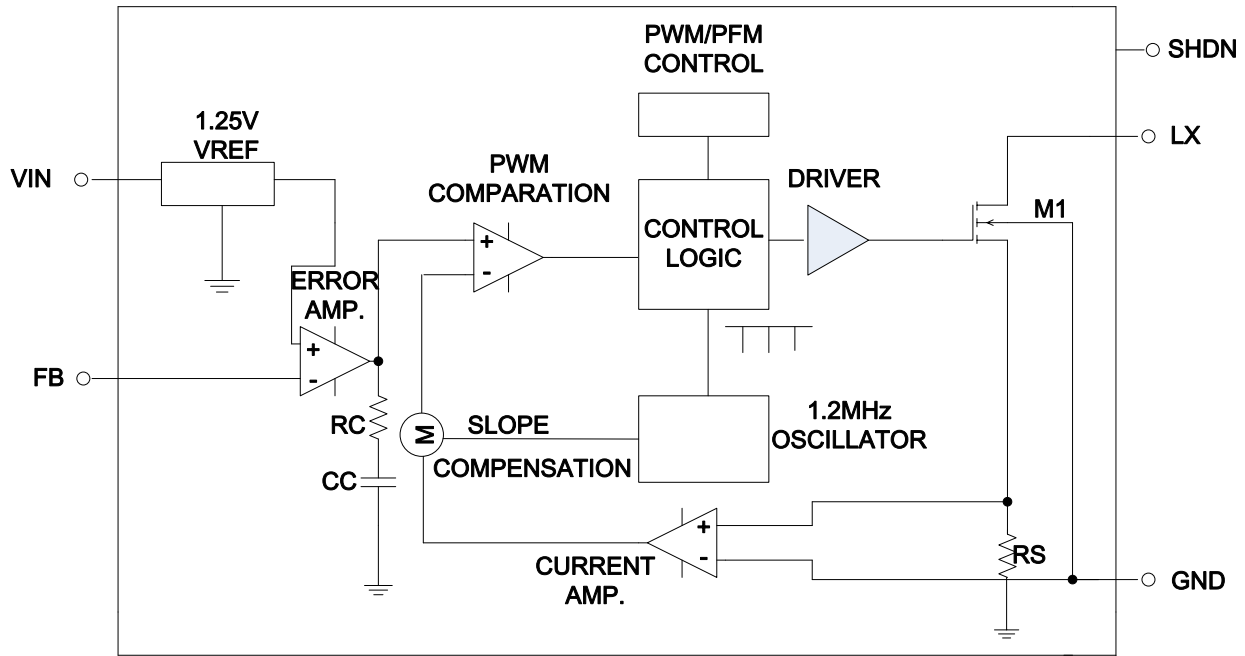

### Absolute Maximum Ratings

- ◇ Supply Input Voltage ----- -0.3V to 6.5V
- ◇ LX Input Voltage ----- -0.3V to 36V
- ◇ The Other Pins ----- -0.3V to 5.5V
- ◇ Power Dissipation, PD @ TA = 25°C TSOT-23-5 ----- 0.45W
- ◇ SOT23-5,  $\theta_{JA}$  ----- 250°C/W
- ◇ Lead Temperature (Soldering, 10 sec.) ----- 260°C
- ◇ Operation Temperature Range ----- -40°C to 85°C
- ◇ Storage Temperature Range ----- -65°C to 150°C



## Electrical Characteristics

| Parameter                    | Symbol          | Test Condition | Min  | Typ. | Max  | Units    |
|------------------------------|-----------------|----------------|------|------|------|----------|
| System Supply Input          |                 |                |      |      |      |          |
| Operation voltage Range      | VDD             |                | 2.2  |      | 6    | V        |
| Under Voltage Lock Out       | VDD             |                | 1.5  | 1.8  | 2.1  | V        |
| Supply Current               | IDD             | FB=1.3V        |      | 430  | 550  | uA       |
| Shut Down Current            | IDD             | VEN=0V         |      | 0.1  | 1    | uA       |
| Line Regulation              |                 | VIN : 3.0~4.3V |      | 0.2  |      | %        |
| Oscillator                   |                 |                |      |      |      |          |
| Operation Frequency          | FOSC            |                |      | 1.2  |      | MHz      |
| Maximum Duty Cycle           |                 |                | 93   |      |      | %        |
| Feedback Voltage             | LP3317          |                | 1.21 | 1.23 | 1.25 | V        |
| MOSFET                       |                 |                |      |      |      |          |
| On Resistance of MOSFET      | RDS(ON)         |                |      | 0.4  |      | $\Omega$ |
| SW Current Limit             | ILM             |                |      | 1.5  |      | A        |
| Protection                   |                 |                |      |      |      |          |
| Shut Down Voltage            | VEN             |                |      |      | 0.4  | V        |
| Enable on Voltage            | VEN             |                | 1.4  |      |      | V        |
| Thermal Shutdown Temperature | T <sub>SD</sub> |                |      | 150  |      | °C       |



### Typical Operating Characteristics

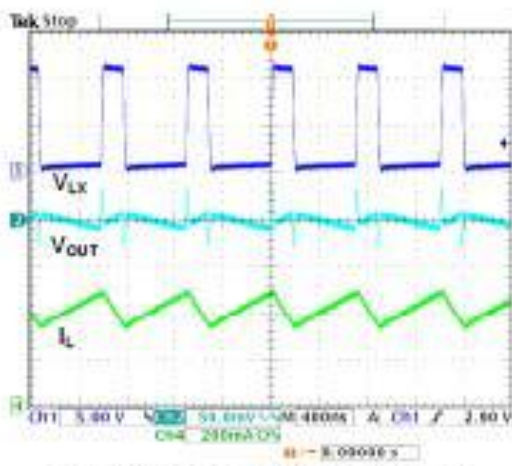
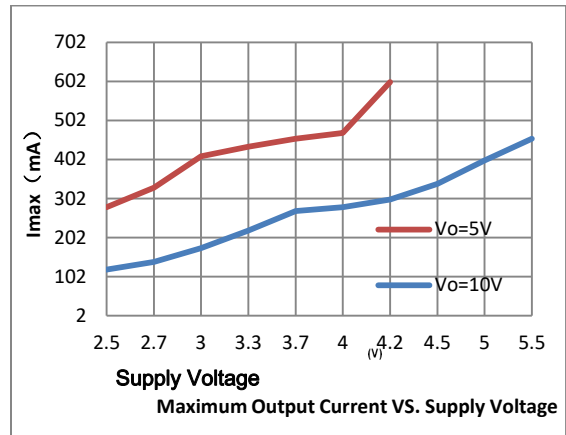
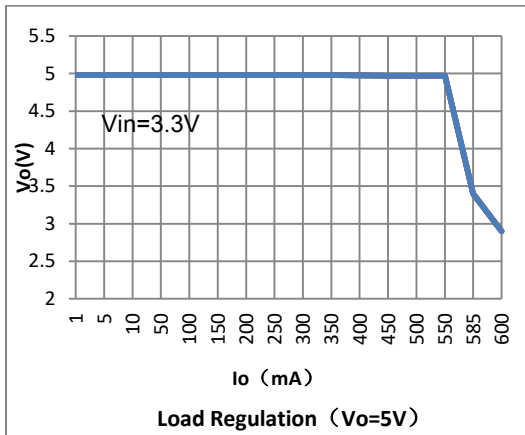

Figure 18. Operation Waveform

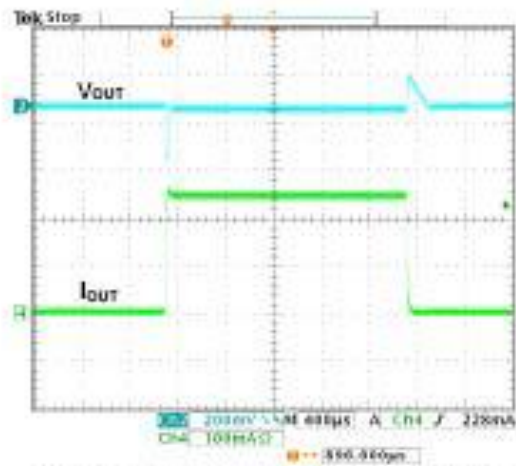

Figure 19. Load Step Response

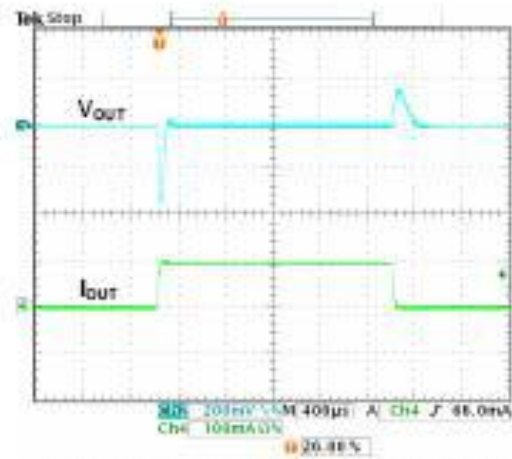

Figure 20. Load Step Response

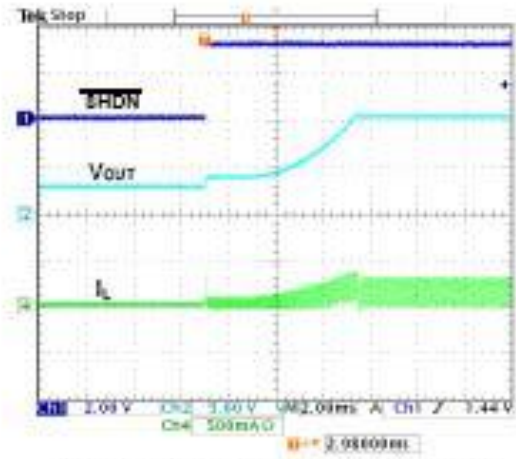

Figure 21. Start-Up from Shutdown



## Applications Information

### Inductor Selection

The recommended value of inductor for 30V applications are 4.7 to 22 $\mu$ H. Small size and better efficiency are the major concerns for portable device, such as LP3317 used for mobile phone. The inductor should have low core loss at 1MHz and low DCR for better efficiency. To avoid inductor saturation current rating should be considered.

### Constant Output Voltage Control

The output voltage of the LP3317 can be adjusted by the divider circuit on the FB pin. Typical FB voltage is 1250mV. The output voltage can be calculated by the following Equations.

$$V_{out}=(R1+R2)/R2*V_{FB}$$

### Power Sequence

In order to assure the normal soft start function for suppressing the inrush current, the input voltage should be ready before EN pulls high.

### Current Limiting

The current flow through inductor as charging period is detected by a current sensing circuit. As the value comes across the current limiting threshold, the N-MOSFET will be turned off so that the inductor will be forced to leave charging stage and enter discharging stage. Therefore, the inductor current will not increase over the current limiting threshold.

### UVLO/OTP

The input voltage is lower than a specified value, the chip will enter protection mode to prevent abnormal function. As the die temperature is higher than 150°C, the chip also will enter protection mode.

The power MOSFET will be turned off during protection mode to prevent abnormal operation.

### Thermal Considerations

For continuous operation, do not exceed absolute maximum operation junction temperature. The maximum power dissipation depends on the thermal resistance of IC package, PCB layout, the rate of surroundings airflow and temperature difference between junction and ambient. The maximum power dissipation can be calculated by following formula:

$$P_D=(T_J-T_A)/\theta_{JA}$$

### Layout Consideration

For best performance of the LP3317, the following guidelines must be strictly followed.

- Input and Output capacitors should be placed close to the IC and connected to ground plane to reduce noise coupling.
- Keep the main current traces as possible as short and wide.
- LX node of DC-DC converter is with high frequency voltage swing. It should be kept at a small area.
- Place the feedback components as close as possible to the IC and keep away from the noisy devices.



### Packaging Information

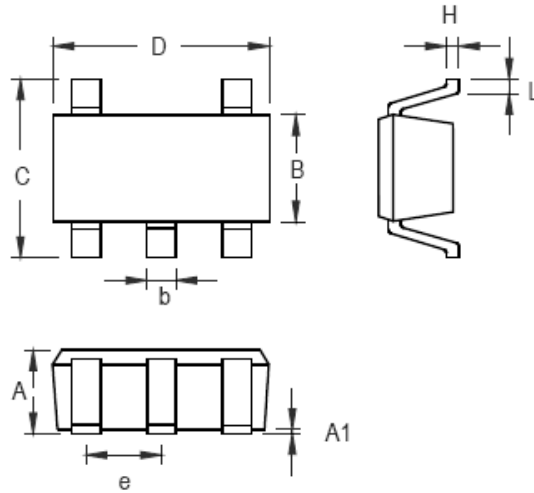

| Symbol | Dimensions In Millimeters |       | Dimensions In Inches |       |
|--------|---------------------------|-------|----------------------|-------|
|        | Min                       | Max   | Min                  | Max   |
| A      | 0.889                     | 1.295 | 0.035                | 0.051 |
| A1     | 0.000                     | 0.152 | 0.000                | 0.006 |
| B      | 1.397                     | 1.803 | 0.055                | 0.071 |
| b      | 0.356                     | 0.559 | 0.014                | 0.022 |
| C      | 2.591                     | 2.997 | 0.102                | 0.118 |
| D      | 2.692                     | 3.099 | 0.106                | 0.122 |
| e      | 0.838                     | 1.041 | 0.033                | 0.041 |
| H      | 0.080                     | 0.254 | 0.003                | 0.010 |
| L      | 0.300                     | 0.610 | 0.012                | 0.024 |

SOT-23-5 Surface Mount Package