



## High Performance, Constant Current Switching Regulator For 8PCS White LED In Series

### General Description

The LP3382S is a 1.2MHz PWM boost switching regulator designed for constant- current white LED driver applications. The LP3382S can drive a string of up to 8 white LEDs in series, ensuring uniform brightness and eliminating several ballast resistors. The LP3382S implements a constant frequency 1.2MHz PWM control scheme. The high frequency PWM operation also saves board space by reducing external component sizes. To improve efficiency, the feedback voltage is set to 250 mV, which reduces the power dissipation in the current setting resistor.

Highly integration and internal compensation network minimizes as 5 external component counts. Optimized operation frequency can meet the requirement of small LC filters value and low operation current with high efficiency.

### Order Information

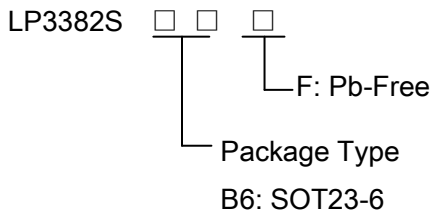

### Applications

- ✧ WLED Backlight driver
- ✧ OLED Backlight driver
- ✧ PDA
- ✧ MID/PTV

### Features

- ◆ High Efficiency: 92%
- ◆ 1.2MHzFixed-Frequency PWM Operation
- ◆ Maximum Output Voltage up to 29V
- ◆ Operating Range : 2.2V to 5.5V
- ◆ Shutdown Supply Current:<1uA
- ◆ Available in SOT23-6 Package
- ◆ Built-in 29V Over Voltage Protection
- ◆ Minimize the External Component
- ◆ RoHS Compliant and 100% Lead (Pb)-Free

### Typical Application Circuit

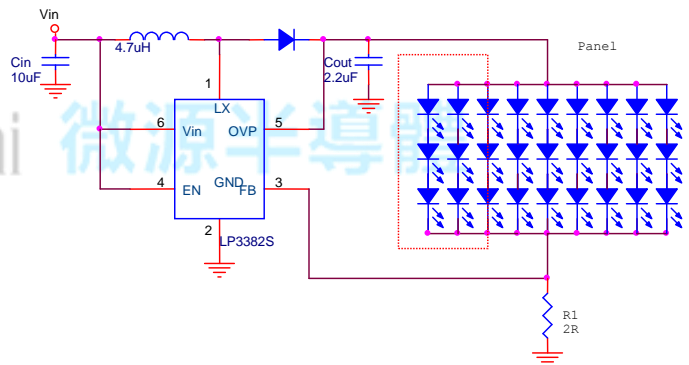

### Marking information

Device	Marking	Package	Shipping
LP3382S		SOT23-6	3K/REEL
Y:Production year W:Production week X:Production batch			

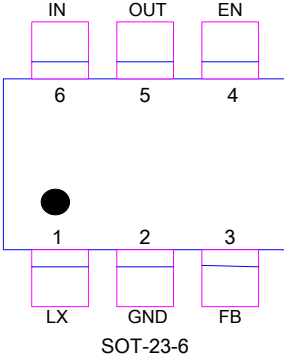

## Functional Pin Description

Package Type	Pin Configurations
SOT23-6	

## Pin Description

Pin	Name	Description
1	LX	Switch Pin. Connect this Pin to inductor and catch diode. Minimize the track area to reduce EMI.
2	GND	Ground Pin
3	FB	Feedback Reference Voltage Pin. Series connect a resistor between WLED and ground as a current sense. Sense the current feedback voltage to set the current rating.
4	EN	Chip Enable (Active High). Voltage sensing input to trigger the function of over voltage protection. Note that this pin is high impedance. There should be a pull low 100kΩ resistor connected to GND when the control signal is floating.
5	OVP	Over voltage pin.
6	Vin	Supply Input Voltage Pin. Bypass 10uF capacitor to GND to reduce the input noise.



### Function Block Diagram

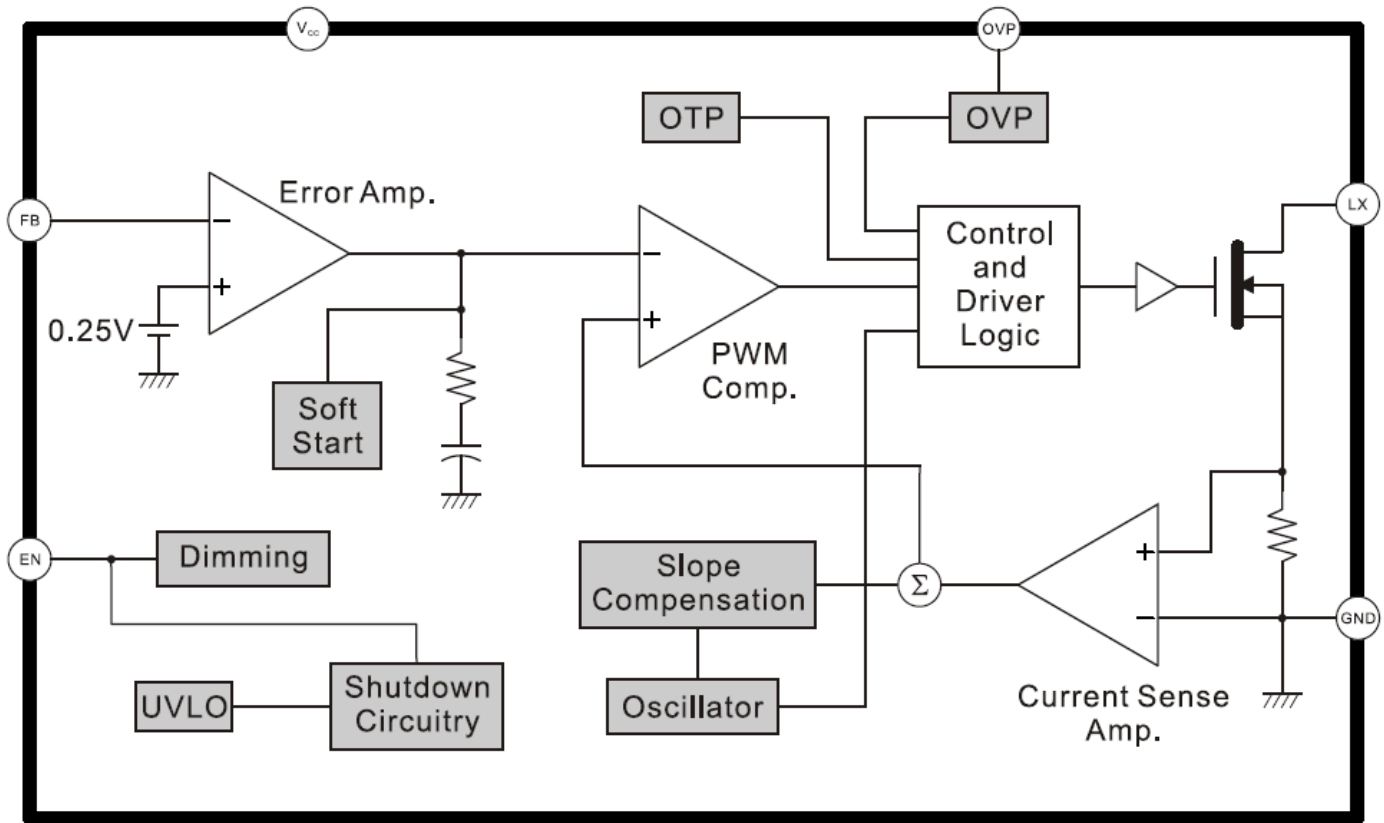

### Absolute Maximum Ratings

- ✧ Supply Input Voltage ----- -0.3V to 6.0V
- ✧ LX/OVP Pin to GND ----- -0.3V to 35V
- ✧ The Other Pins ----- -0.3V to 5.5V
- ✧ Power Dissipation, PD @ TA = 25°C SOT-23-6 ----- 0.45W
- ✧ Lead Temperature (Soldering, 10 sec.) ----- 260°C
- ✧ Operation Temperature Range ----- -20°C to 85°C
- ✧ Storage Temperature Range ----- -65°C to 150°C

### ESD Susceptibility

- ✧ HBM(Human Body Mode) ----- 2KV
- ✧ MM(Machine Mode) ----- 200V



### Typical Application Circuit

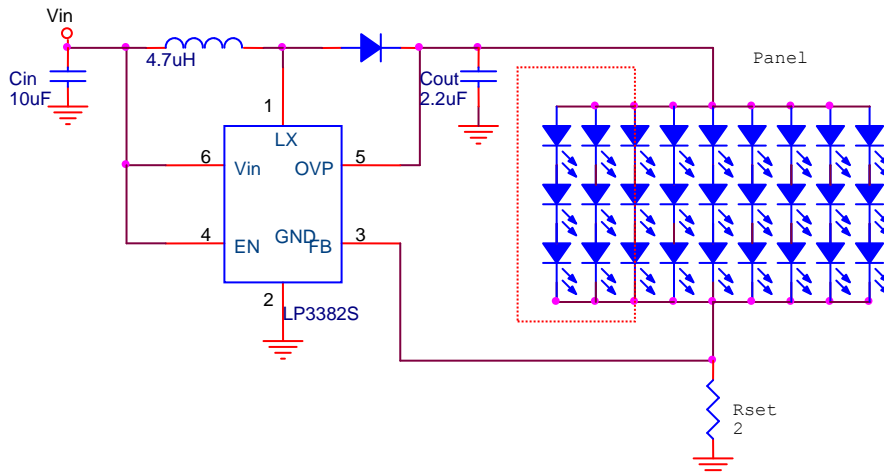
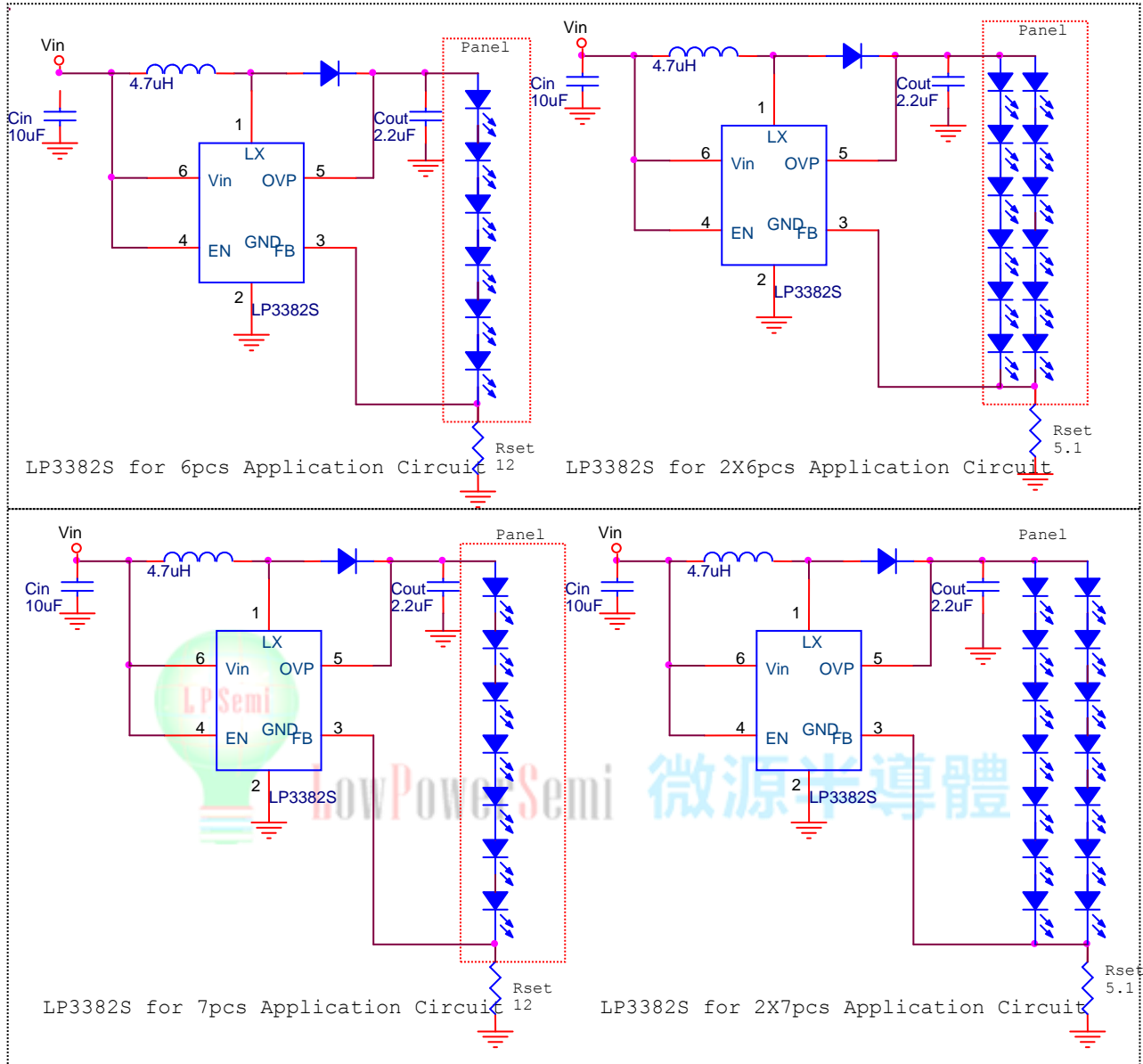



## Electrical Characteristics

Parameter	Symbol	Test Condition	Min	Typ.	Max	Units
<b>System Supply Input</b>						
Operation voltage Range	VDD		2.2		5.5	V
Under Voltage Lock Out	VDD			1.8		V
Supply Current	IDD	FB=0.2V, Switch		90		uA
Shut Down Current	IDD	VEN < 0.4V		0.1	1	uA
Line Regulation		VIN : 3.0~4.3V		2		%
<b>Oscillator</b>						
Operation Frequency	FOSC			1.2		MHz
Maximum Duty Cycle			93			%
Feedback Voltage	LP3382		235	250	265	mV
<b>MOSFET</b>						
On Resistance of MOSFET	RDS(ON)			0.3		Ω
SW Current Limit	ILM			2		A
<b>Protection</b>						
OVP Threshold	VOVP			29		V
OVP Sink Current				5		μA
Shut Down Voltage	VEN				0.4	V
Enable on Voltage	VEN		1.4			V
PWM EN Dimming range			100		200K	Hz



### Typical Operating Characteristics

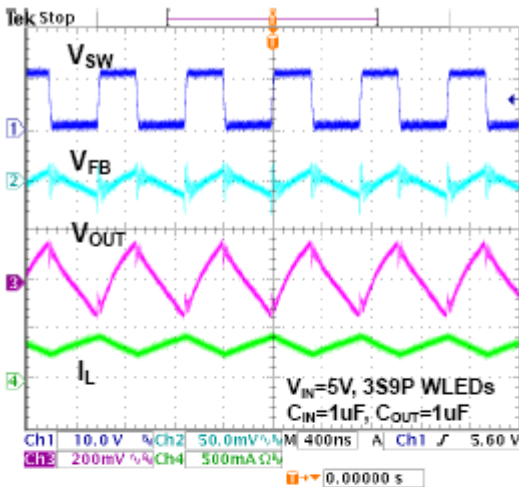

Switch waveforms

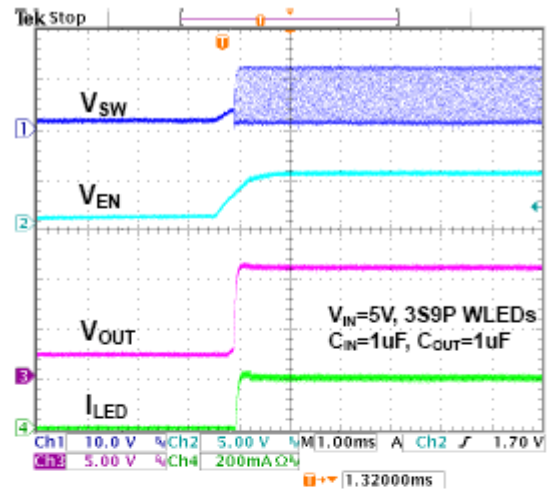

Enable Startup Response Waveforms

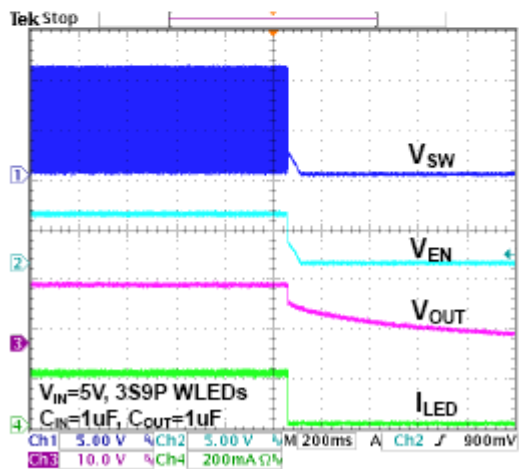

Enable Shutdown Response Waveforms

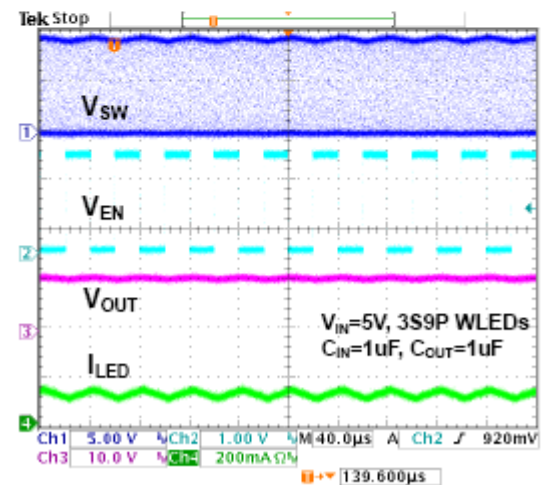

PWM Dimming Response Waveforms at a frequency of 25kHz

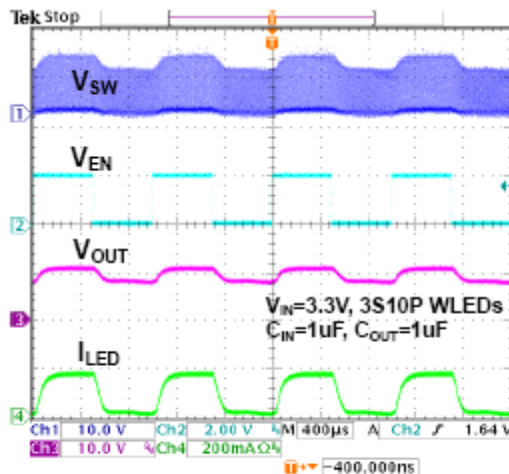

Figure 8. PWM Dimming Response Waveforms at a frequency of 1kHz



## Applications Information

### LED Current Control

The LP3382S regulates the LED current by setting the current sense resistor (R1) connecting to feedback and ground. The internal feedback reference voltage is 250mV. The LED current can be set from following equation easily.

$$I_{LED} = 250mV/R1$$

In order to have an accurate LED current, precision resistors are preferred (1% is recommended). The table for R1 selection is shown below.

### Power Sequence

In order to assure the normal soft start function for suppressing the inrush current the input voltage should be ready before EN pulls high.

### Soft-Start

The function of soft-start is made for suppressing the inrush current to an acceptable value at the beginning of power-on. The LP3382S provides a built-in soft-start function by clamping the output voltage of error amplifier so that the duty cycle of the PWM will be increased gradually in the soft-start period.

### Current Limiting

The current flow through inductor as charging period is detected by a current sensing circuit. As the value comes across the current limiting threshold, the N-MOSFET will be turned off so that the inductor will be forced to leave charging stage and enter discharging stage. Therefore, the inductor current will not increase over the current limiting threshold.

### OVP/UVLO/OTP

The Over Voltage Protection is detected by a junction breakdown detecting circuit. Once VOUT goes over the detecting voltage, LX pin stops switching and the power N-MOSFET will be turned off. Then, the VOUT will be clamped to be near VOVP. As the output voltage is higher than a specified value or input voltage is lower than a specified value, the chip will enter protection mode to prevent abnormal function. As the die temperature is higher than 150°C, the chip also will enter protection mode. The power MOSFET will be turned off during protection mode to prevent abnormal operation.

### Inductor Selection

The recommended value of inductor for 2 to 8WLEDs applications are 4.7 to 22μH. Small size and better efficiency are the major concerns for portable device, such as LP3382S used for mobile phone. The inductor should have low core loss at 1.2MHz and low DCR for better efficiency. To avoid inductor saturation current rating should be considered.

### Capacitor Selection

Input ceramic capacitor of 10uF and output ceramic capacitor of 1uF are recommended for the LP3382S applications for driving 8 series WLEDs. For better voltage filtering, ceramic capacitors with low ESR are recommended. X5R and X7R types are suitable because of their wider voltage and temperature ranges.





### Dimming control

#### a. Using a PWM Signal to EN Pin

For controlling the LED brightness, the LP3382S can perform the dimming control by applying a PWM signal to EN pin. The internal soft-start and wide range dimming frequency from 100Hz to 200KHz can insignificantly reduce audio noise when dimming. The average LED current is proportional to the PWM signal duty cycle. The magnitude of the PWM signal should be higher than the maximum enable voltage of EN pin, in order to let the dimming control perform correctly.

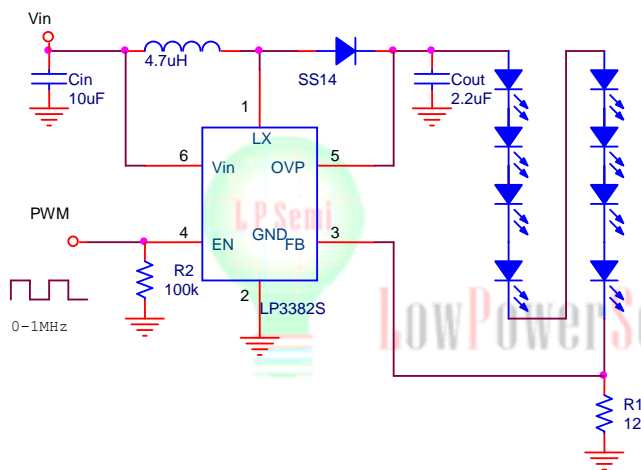

#### b. Using a DC Voltage

Using a variable DC voltage to adjust the brightness is a popular method in some applications. The dimming control using a DC voltage circuit is shown in Figure 4. According to the Superposition Theorem, as the DC voltage increases, the voltage contributed to VFB increases and the voltage drop on R2 decreases, i.e. the LED current decreases. For example, if the VDC range is from 0V to 2.8V, the selection of resistors in Figure 4 sets dimming control of LED current from 20mA to 0mA.

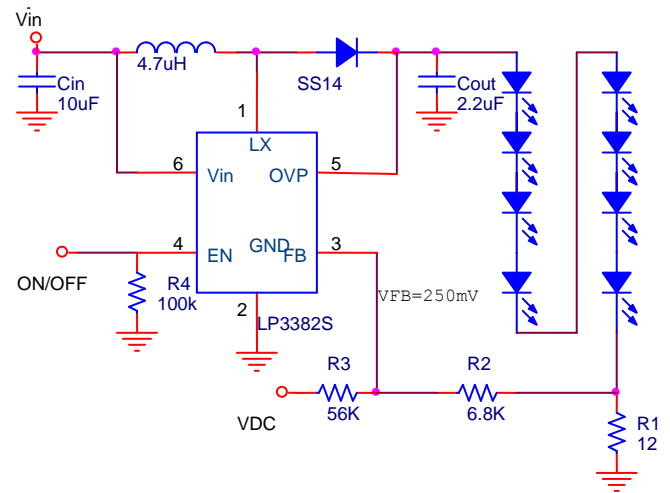

#### c. Using a Filtered PWM signal

Another common application is using a filtered PWM signal as an adjustable DC voltage for LED dimming control. A filtered PWM signal acts as the DC voltage to regulate the output current. The suggested application circuit is shown in the Figure 6. In this circuit, the output ripple depends on the frequency of PWM signal. For smaller output voltage ripple (<100mV), the recommended frequency of PWM signal should be above 2kHz. To fix the frequency of PWM signal and change the duty cycle of PWM signal can get different output current. According to the application circuit, output current is from 20.5mA to 5.5mA by adjusting the PWM duty cycle from 10% to 90%.

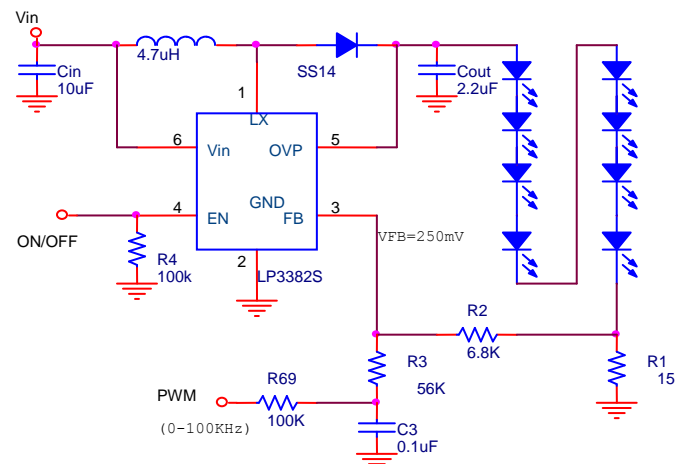





## Layout Consideration

For best performance of the LP3382S, the following guidelines must be strictly followed.

- ※ Input and Output capacitors should be placed close to the IC and connected to ground plane to reduce noise coupling.
- ※ The GND and Exposed Pad should be connected to a strong ground plane for heat sinking and noise protection.
- ※ Keep the main current traces as possible as short and wide.
- ※ LX node of DC-DC converter is with high frequency voltage swing. It should be kept at a small area.
- ※ Place the feedback components as close as possible to the IC and keep away from the noisy devices.





### Packaging Information

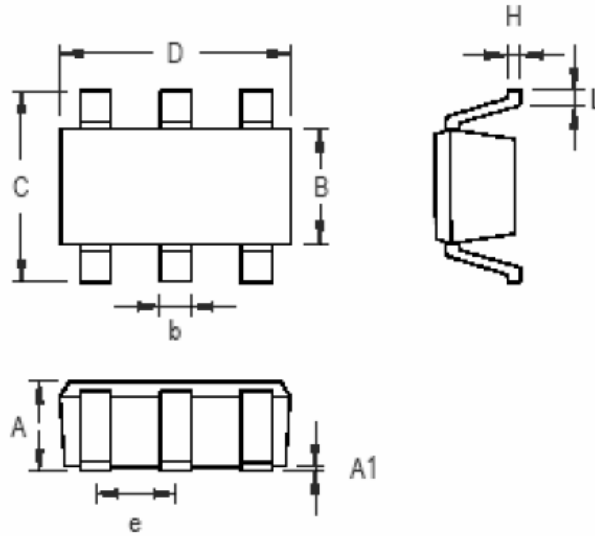

Symbol	Dimensions In Millimeters		Dimensions In Inches	
	Min	Max	Min	Max
A	0.889	1.295	0.031	0.051
A1	0.000	0.152	0.000	0.006
B	1.397	1.803	0.055	0.071
b	0.250	0.560	0.010	0.022
C	2.591	2.997	0.102	0.118
D	2.692	3.099	0.106	0.122
e	0.838	1.041	0.033	0.041
H	0.080	0.254	0.003	0.010
L	0.300	0.610	0.012	0.024

SOT-23-6 Surface Mount Package