

Features

- Single-Supply Operation from 2.5V~+5.5V
- Rail-to-Rail Output
- -3dB Bandwidth(G=+1): 250MHz (Typ.)
- Low Input Bias Current: 1pA (Typ.)
- Quiescent Current: 2.8mA/Amplifier (Typ.)
- Operating Temperature: -40°C ~ +125°C
- Small Package:
 - CBM8051 Available in SOT23-5 and SC70-5 Packages
 - CBM8052 Available in SOP-8 and MSOP-8 Packages
 - CBM8054 Available in SOP-14 and TSSOP-14 Packages
 - CBM8051N Available in SOT23-6 and SC70-6 Packages
 - CBM8052N Available in MSOP-10 Packages

Application

- Imaging
- Photodiode Preamp
- DVD/CD
- Filters
- Professional Video and Cameras
- Hand Sets
- Base Stations
- to-D Driver

Description

The CBM8051 / 1N (single), CBM8052 /2N(dual), CBM8054 (quad) are rail-to-rail output voltage feedback amplifiers offering ease of use and low cost. They have bandwidth and slew rate typically found in current feedback amplifiers. All have a wide input common-mode voltage range and output voltage swing, making them easy to use on single supplies as low as 2.5V. Despite being low cost, the CBM8051 series provide excellent overall performance. They offer wide bandwidth to 250MHz (G =+1) along with 0.1dB flatness out to 52MHz (G= +2) and offer a typical low power of 2.8mA/amplifier.

The CBM8051 series is low distortion and fast settling make it ideal for buffering high speed A/D or D/A converters. The CBM8051/2N has a power-down disable feature that reduces the supply current to 50μA. These features make the CBM8051/2N ideal for portable and battery-powered applications where size and power are critical. All are specified over the extended -40 °C to +125°C temperature range.

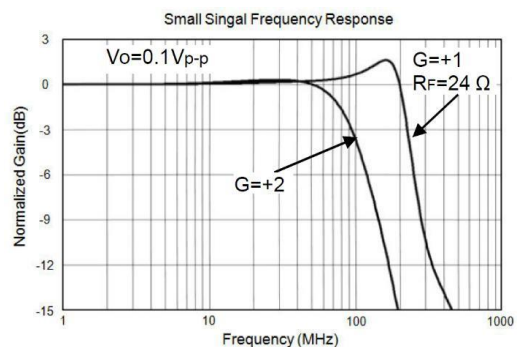

CATALOG

Features.....	
Application	
Description.....	
Pin Configurations.....	1
Absolute Maximum Ratings.....	2
Electrical Characteristics	3
Electrical Performance Characteristics.....	5
Typical Characteristics.....	7
Typical Performance Characteristics	8
Application Notes	10
Typical Application Circuits.....	12
Package Outline Dimensions.....	14
MSOP-8.....	14
TSSOP-14.....	15
SOIC-8(SOP8).....	16
SOIC-14(SOP14).....	17
SOT23-5	18
SC70-5.....	19
SOT23-6	20
MSOP-10.....	21
Package/Ordering Information	22

Pin Configurations

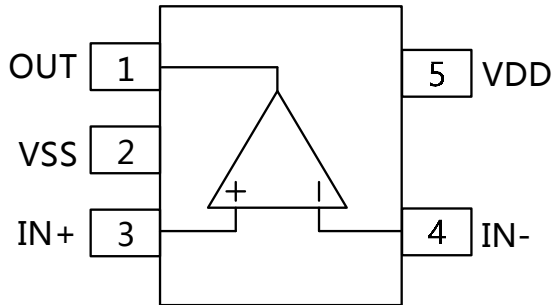

SOT23-5/SC70-5

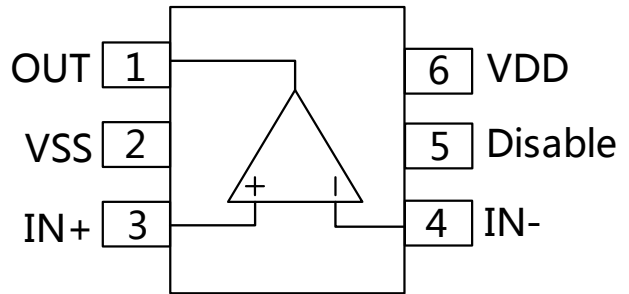

SOT23-6/SC70-6

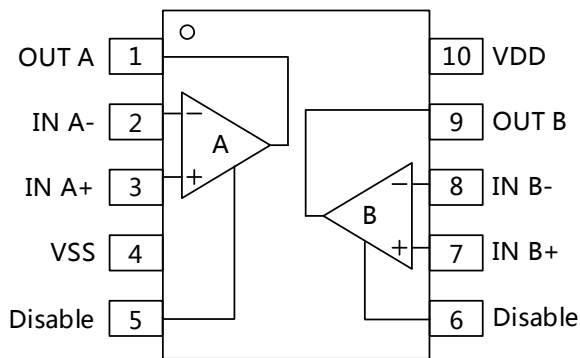

MSOP-10

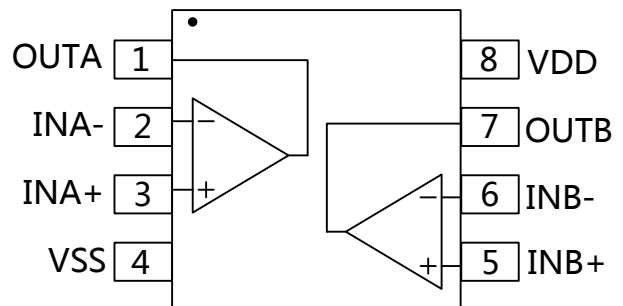

SOP-8/MSOP-8

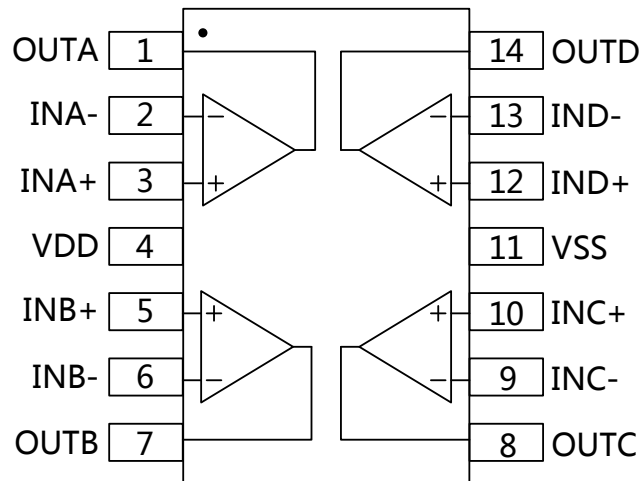

SOP-14/TSSOP-14

Figure 1. Pin Assignment Diagram

Absolute Maximum Ratings

Condition	Min	Max
Power Supply Voltage (V_{DD} to V_{SS})	-0.5V	+7.5V
Analog Input Voltage (IN+ or IN-)	$V_{SS}-0.5V$	$V_{DD}+0.5V$
PDB Input Voltage	$V_{SS}-0.5V$	+7V
Operating Temperature Range	-45°C	+125°C
Junction Temperature	+160°C	
Storage Temperature Range	-55°C	+150°C
Lead Temperature (soldering, 10sec)	+260°C	
Package Thermal Resistance ($T_A = +25^\circ\text{C}$)		
SOP-8, θ_{JA}	125°C/W	
MSOP-8, θ_{JA}	216°C/W	
SOT23-5, θ_{JA}	190°C/W	
SOT23-6, θ_{JA}	190°C/W	
SC70-5, θ_{JA}	333°C/W	
ESD Susceptibility		
HBM	6KV	
MM	400V	

Note: Stress greater than those listed under Absolute Maximum Ratings may cause permanent damage to the device. This is a stress rating only and functional operation of the device at these or any other conditions outside those indicated in the operational sections of this specification are not implied. Exposure to absolute maximum rating conditions for extended periods may affect reliability.

Electrical Characteristics

(G= +2, RF=887Ω, RG=887Ω, and RL=150Ω connected to VS/2, unless otherwise noted. Typical values are at TA = +25°C.)

PARAMETER	CONDITIONS	CBM8051/CBM8052/CBM8054/CBM8051N/CBM8052N							
		TYP	MIN/MAX OVER TEMPERATURE					UNITS	MIN/MAX
		+25°C	+25°C	0°C to 70°C	-40°C to 85°C	-40°C to 125°C			
DYNAMIC PERFORMANCE									
3dB Small Signal Bandwidth	G= +1,Vo=0.1Vp-,Rf=24Ω,Rl=150Ω	180					MHz	TYP	
	G= +1,Vo=0.1Vp-p,Rf=24Ω,Rl=1kΩ	250					MHz	TYP	
	G= +2,Vo=0.1Vp-p,Rl=50Ω	55					MHz	TYP	
	G= +2,Vo=0.1Vp-p,Rl=150Ω	93					MHz	TYP	
	G= +2,Vo=0.1Vp-p,Rl=1kΩ	122					MHz	TYP	
	G= +2,Vo=0.1Vp-p,Rl=10kΩ	130					MHz	TYP	
Gain-Bandwidth Product	G= +10,Rl=150Ω	115					MHz	TYP	
	G= +10,Rl=1kΩ	150					MHz	TYP	
Bandwidth for 0.1dB Flatness	G= +2,Vo=0.1Vp-,Rl=150Ω,Rf=887Ω	52					MHz	TYP	
Slew Rate	G= +1,2VOutputStep	77/-151					V/μs	TYP	
	G= +2,2VOutputStep	88/-119					V/μs	TYP	
	G= +2,4VOutputStep	93/-131					V/μs	TYP	

Rise-and-Fall Time	$G=+2, V_o=0.2V_{p-p}, 10\% \text{ to } 90\%$	4.5					ns	TYP
	$G=+2, V_o=2V_{p-p}, 10\% \text{ to } 90\%$	18					ns	TYP
Settling Time to 0.1%	$G=+2, 2V_{\text{Output Step}}$	50					ns	TYP
Overload Recovery Time	$V_{IN}, G=+VS$	18					ns	TYP
NOISE/DISTORTION PERFORMANCE								
Input Voltage Noise	$f = 1\text{MHz}$	4.9					nV/Hz	TYP
Differential Gain Error (NTSC)	$G = +2, R_L = 150\Omega$	0.03					%	TYP
Differential Phase Error (NTSC)	$G = +2, R_L = 1k\Omega$	0.08					degree	TYP
DC PERFORMANCE								
Input Offset Voltage (V_{OS})		± 2	± 8	± 8.9	± 9.5	± 9.8	mV	MAX
Input Offset Voltage Drift		2					$\mu\text{V}/^\circ\text{C}$	TYP
Input Bias Current (I_B)		1					pA	TYP
Input offset Current (I_{OS})		2					pA	TYP
Open-Loop Gain (A_{OL})	$V_O = 0.3V \text{ to } 4.7V, R_L = 150\Omega$	80	75	74	74	73	dB	MIN
	$V_O = 0.2V \text{ to } 4.8V, R_L = 1k\Omega$	104	91	91	91	80	dB	MIN
INPUT CHARACTERISTICS								
Input Common-Mode Voltage Range (V_{CM})		-0.2 to +3.8					V	TYP
Common-Mode Rejection Ratio (CMRR)	$V_{CM} = -0.1V \text{ to } +3.5V$	80	66	65	65	62	dB	MIN

Electrical Performance Characteristics

(G= +2, RF=887Ω, RG=887Ω, and RL=150Ω connected to VS/2, unless otherwise noted. Typical values are at TA =+25°C.)

PARAMETER	CONDITIONS	CBM8051/CBM8052/CBM8054/CBM8051N/CBM8052N							
		TYP	MIN/MAX OVER TEMPERATURE					UNITS	MIN/MAX
		+25°C	+25°C	0°C to 70°C	-40°C to 85°C	-40°C to 125°C			
OUTPUT CHARACTERISTICS									
Output Voltage Swing from Rail	RL = 150Ω	0.12					V	TYP	
	RL = 1kΩ	0.03					V	TYP	
Output Current	f<100kHz	130	100	95	90	84	mA	MIN	
Closed-Loop Output Impedance		0.08						TYP	
POWER-DOWN DISABLE									
(CBM8091/2N only) Turn-On Time							ns	TYP	
Turn-Off Time		236					ns	TYP	
DISABLE Voltage-Off		52	0.8				V	MAX	
DISABLE Voltage-On			2				V	MIN	
POWER SUPPLY									
Operating Voltage Range			2.5	2.7	2.7	2.7	V	MIN	
		2.8	5.5	5.5	5.5	5.5	V	MAX	

Quiescent Current (per amplifier)		50	3	3.2	3.6	3.8	mA	MAX
Supply Current when Disabled per amplifier(CBM8051/2N only)	$\Delta VS = +2.7V$ to $+5.5V$, $VCM = (-VS) + 0.5$	80	70	85	137	137	μA	MAX
Power Supply Rejection Ratio (PSRR)			67	67	62	62	dB	MIN

Typical Characteristics

($V_s = +5V, G = +2, R_F = 887\Omega, R_G = 887\Omega,$ and $R_L = 150\Omega$ connected to $V_s/2$, unless otherwise noted. Typical values are at $T_A = +25^\circ C$.)

Non-Inverting Large-Signal Step Response

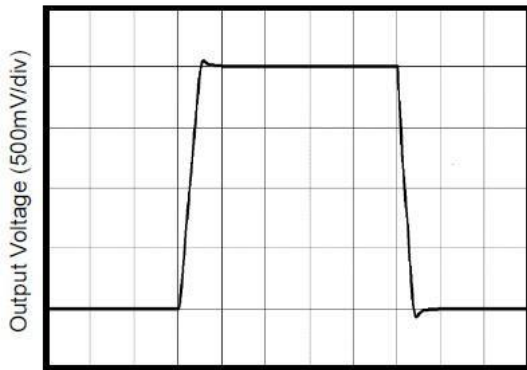

Time (50ns/div)

Non-Inverting Small-Signal Step Response

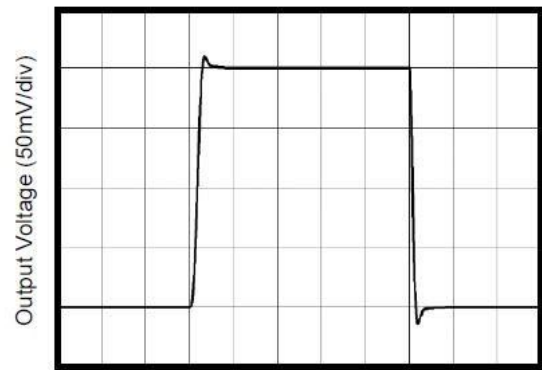

Time (50ns/div)

Supply Current vs. Temperature

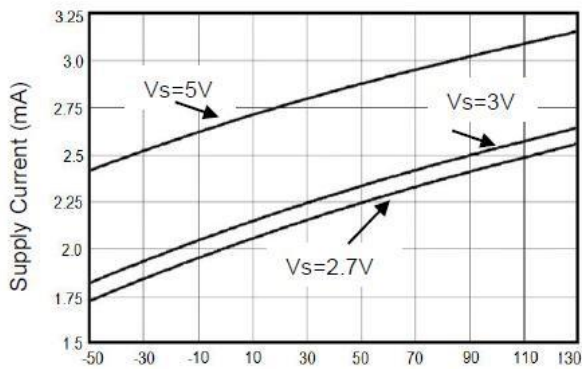

Temperature ($^\circ C$)

Shutdown Current vs. Temperature

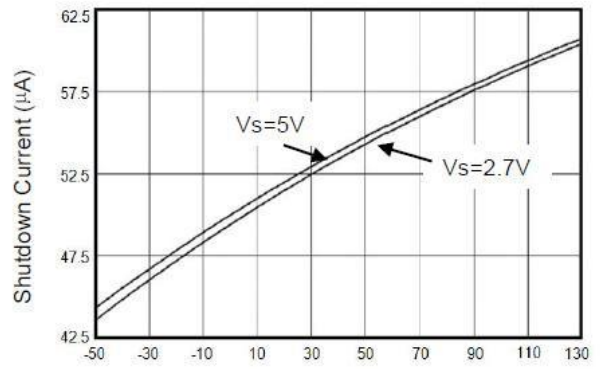

Temperature ($^\circ C$)

Output Voltage Swing vs. Output Current

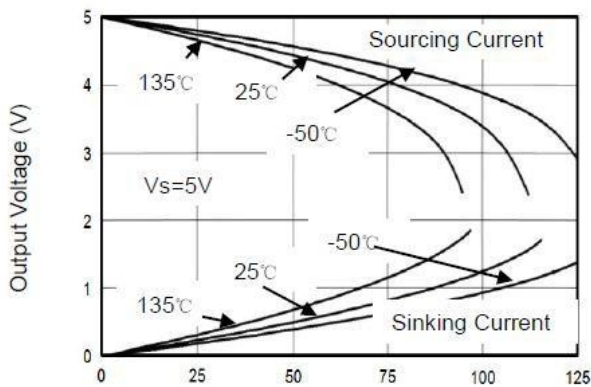

Output Current (mA)

Output Voltage vs. Output Current

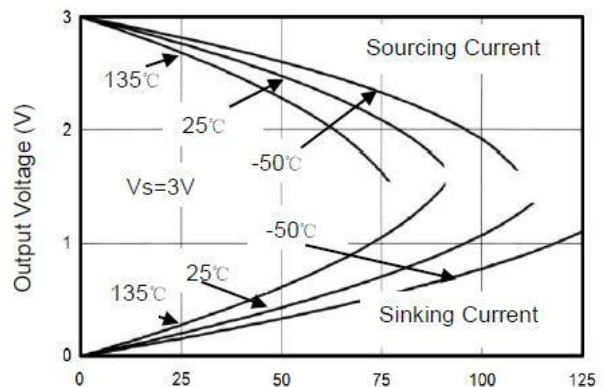

Output Current (mA)

Typical Performance Characteristics

($V_s = +5V, G = +2, R_F = 887\Omega, R_G = 887\Omega,$ and $R_L = 150\Omega$ connected to $V_s/2$, unless otherwise noted.

Typical values are at $T_A = +25^\circ C$.)

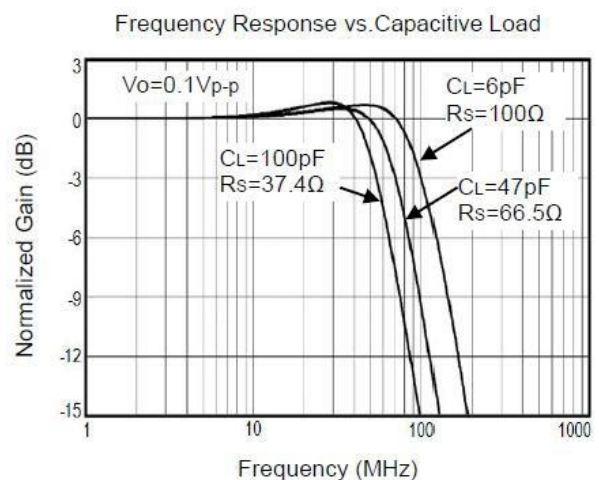
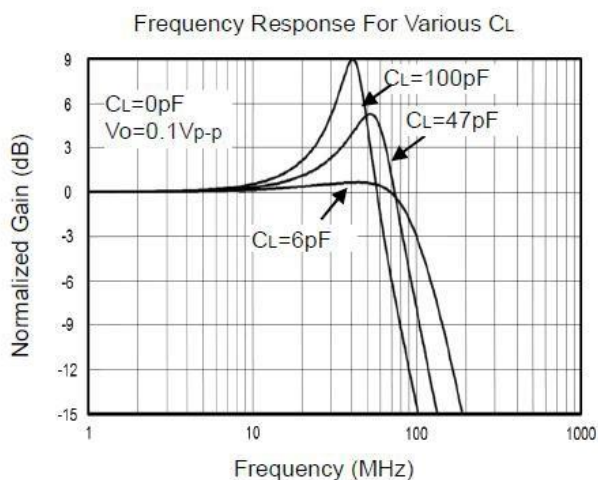
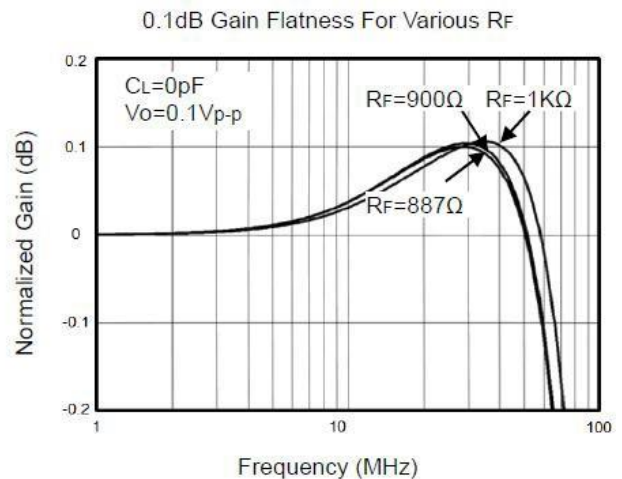
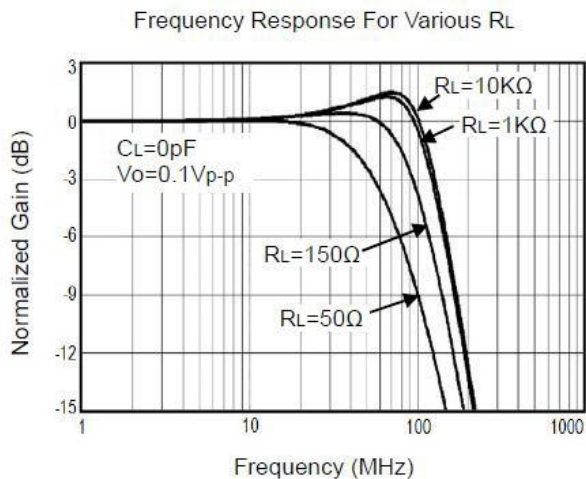
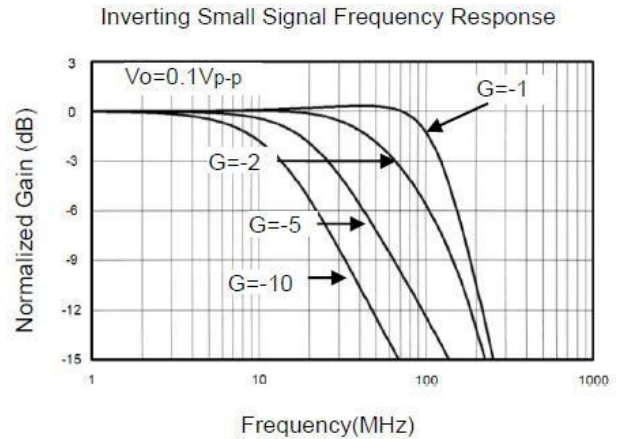
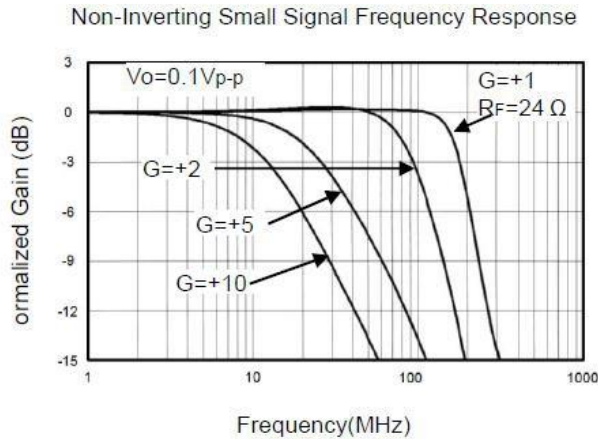

Typical Performance Characteristics

($V_S = +5V, G = +2, R_F = 887\Omega, R_G = 887\Omega,$ and $R_L = 150\Omega$ connected to $V_S/2$, unless otherwise noted.

Typical values are at $T_A = +25^\circ\text{C}$.)

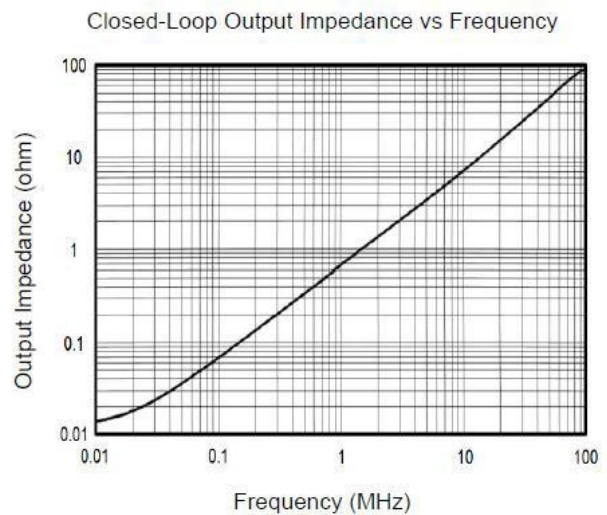
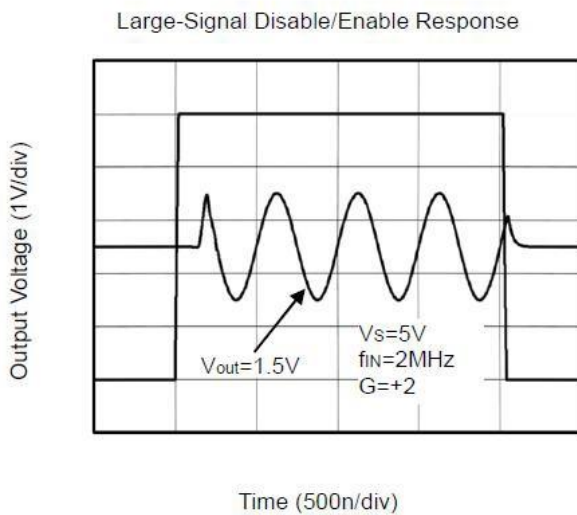
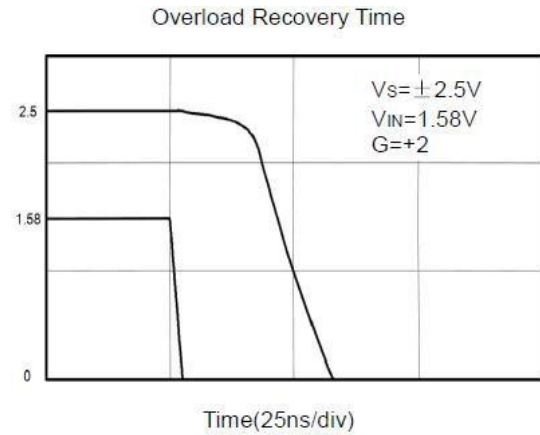
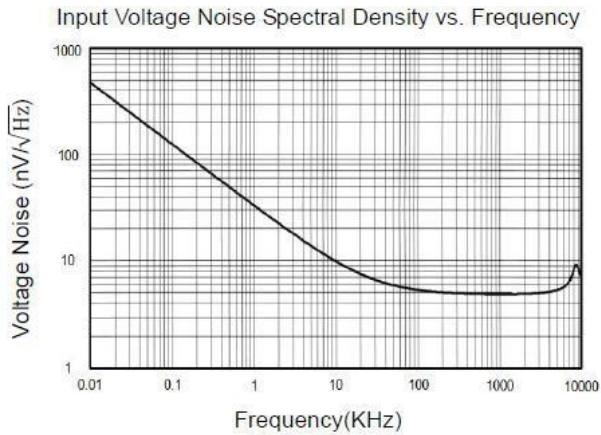

Application Notes

Driving Capacitive Loads

CBM805X series op amps are unity-gain stable and suitable for a wide range of general-purpose applications. The small footprints of the CBM805X series packages save space on printed circuit boards and enable the design of smaller electronic products.

Power Supply Bypassing and Board Layout

CBM805X series operates from a single 2.5V to 5.5V supply or dual $\pm 1.25\text{V}$ to $\pm 2.75\text{V}$ supplies. For best performance, a $0.1\mu\text{F}$ ceramic capacitor should be placed close to the VDD pin in single supply operation. For dual supply operation, both VDD and VSS supplies should be bypassed to ground with separate $0.1\mu\text{F}$ ceramic capacitors.

Low Supply Current

The low supply current (typical 2.8mA per channel) of CBM805X series will help to maximize battery life. They are ideal for battery powered systems

Operating Voltage

CBM805X series operate under wide input supply voltage (2.5V to 5.5V). In addition, all temperature specifications apply from -40°C to $+125^{\circ}\text{C}$. Most behavior remains unchanged throughout the full operating voltage range. These guarantees ensure operation throughout the single Li-Ion battery lifetime

Rail-to-Rail Output

Rail-to-Rail output swing provides maximum possible dynamic range at the output. This is particularly important when operating in low supply voltages. The output voltage of CBM805X series can typically swing to less than 8mV from supply rail in light resistive loads ($>1\text{k}\Omega$), and 30mV of supply rail in moderate resistive loads (150Ω).

Capacitive Load Tolerance

The CBM805X family is optimized for bandwidth and speed, not for driving capacitive loads. Output capacitance will create a pole in the amplifier's feedback path, leading to excessive peaking and potential oscillation. If dealing with load capacitance is a requirement of the application, the two strategies to consider are (1) using a small resistor in series with the amplifier's output and the load capacitance and (2) reducing the bandwidth of the amplifier's feedback loop by increasing the overall noise gain. Figure 2. shows a unity gain follower using the series resistor strategy. The resistor isolates the output from the capacitance and, more importantly, creates a zero in the feedback path that compensates for the pole created by the output capacitance.

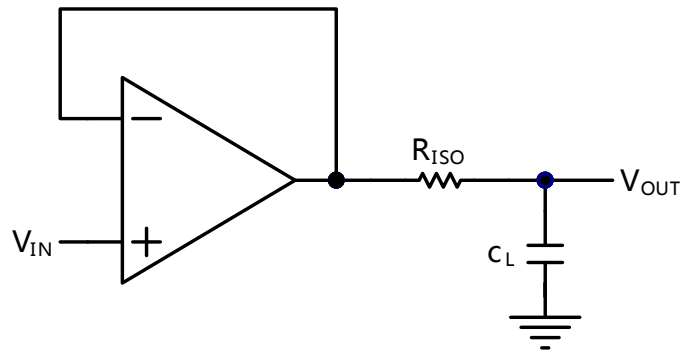

Figure 2. Indirectly Driving a Capacitive Load Using Isolation Resistor

The bigger the R_{ISO} resistor value, the more stable V_{OUT} will be. However, if there is a resistive load R_L in parallel with the capacitive load, a voltage divider (proportional to R_{ISO}/R_L) is formed, this will result in a gain error.

The circuit in Figure 3 is an improvement to the one in Figure 2. R_F provides the DC accuracy by feed-forward the V_{IN} to R_L . C_F and R_{ISO} serve to counteract the loss of phase margin by feeding the high frequency component of the output signal back to the amplifier's inverting input, thereby preserving the phase margin in the overall feedback loop. Capacitive drive can be increased by increasing the value of C_F . This in turn will slow down the pulse response.

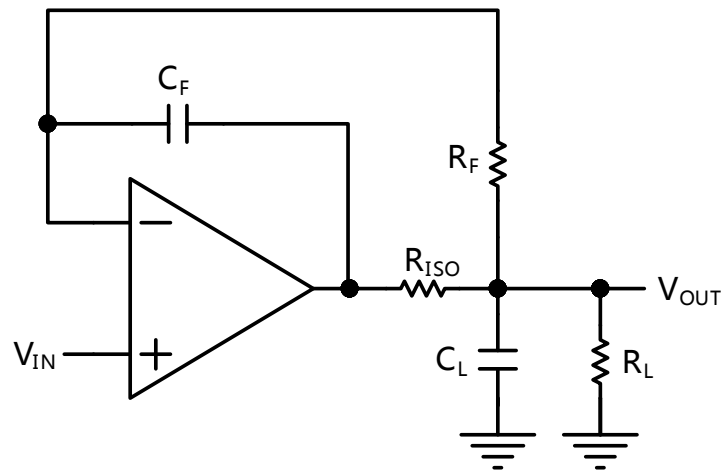

Figure 3. Indirectly Driving a Capacitive Load with DC Accuracy

Typical Application Circuits

Differential amplifier

The differential amplifier allows the subtraction of two input voltages or cancellation of a signal common to the two inputs. It is useful as a computational amplifier in making a differential to single-end conversion or in rejecting a common mode signal. Figure 4. shown the differential amplifier using CBM805X.

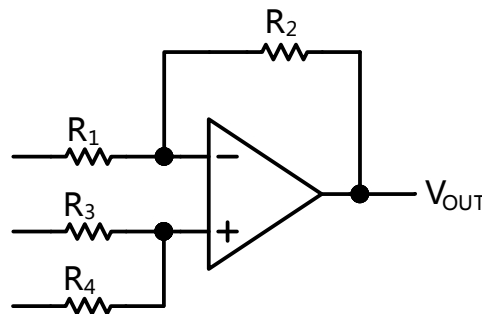

Figure 4. Differential Amplifier

$$V_{OUT} = \left(\frac{R_1 + R_2}{R_3 + R_4} \right) \frac{R_4}{R_1} V_{It} - \frac{R_2}{R_1} V_{It} + \left(\frac{R_1 + R_2}{R_3 + R_4} \right) \frac{R_3}{R_1} V_{Rth}$$

If the resistor ratios are equal (i.e. $R_1=R_3$ and $R_2=R_4$), then

$$V_{OUT} = \frac{R_2}{R_1} (V_{It} - V_{It}) + V_{Rth}$$

Low Pass Active Filter

The low pass active filter is shown in Figure 5. The DC gain is defined by $-R_2/R_1$. The filter has a -20dB/decade roll-off after its corner frequency $f_C=1/(2\pi R_3 C_1)$.

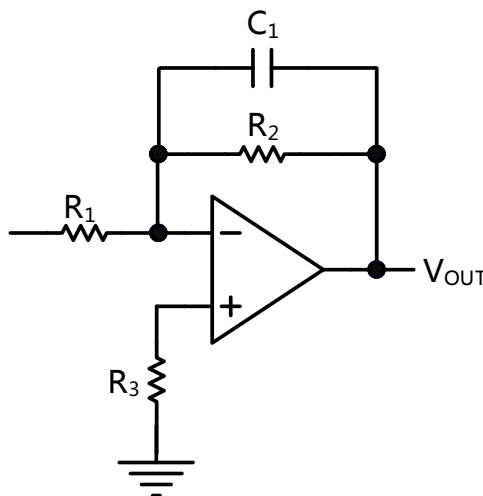

Figure 5. Low Pass Active Filter

Driving Video

The CBM805x can be used in video applications like in Figure 6.

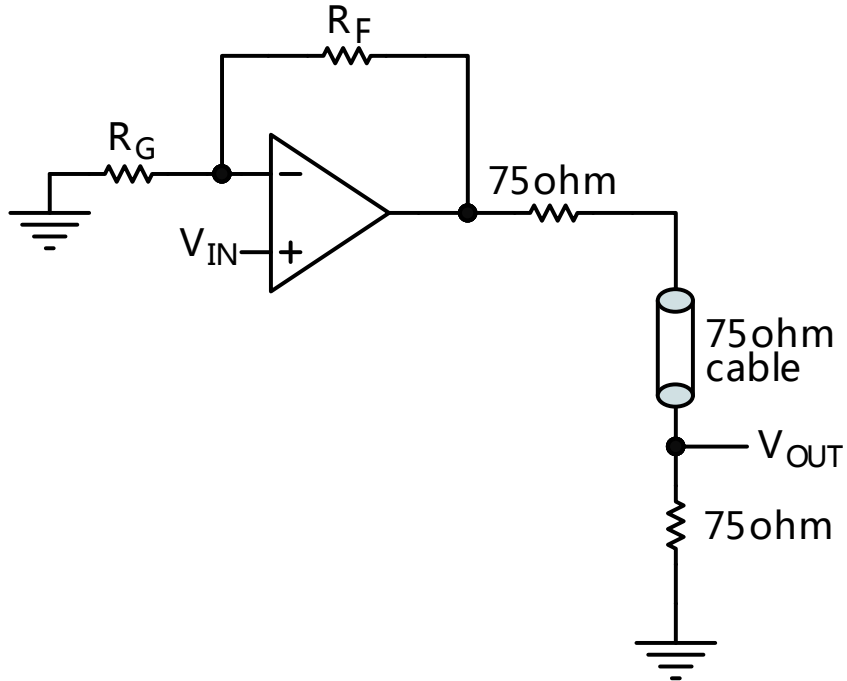
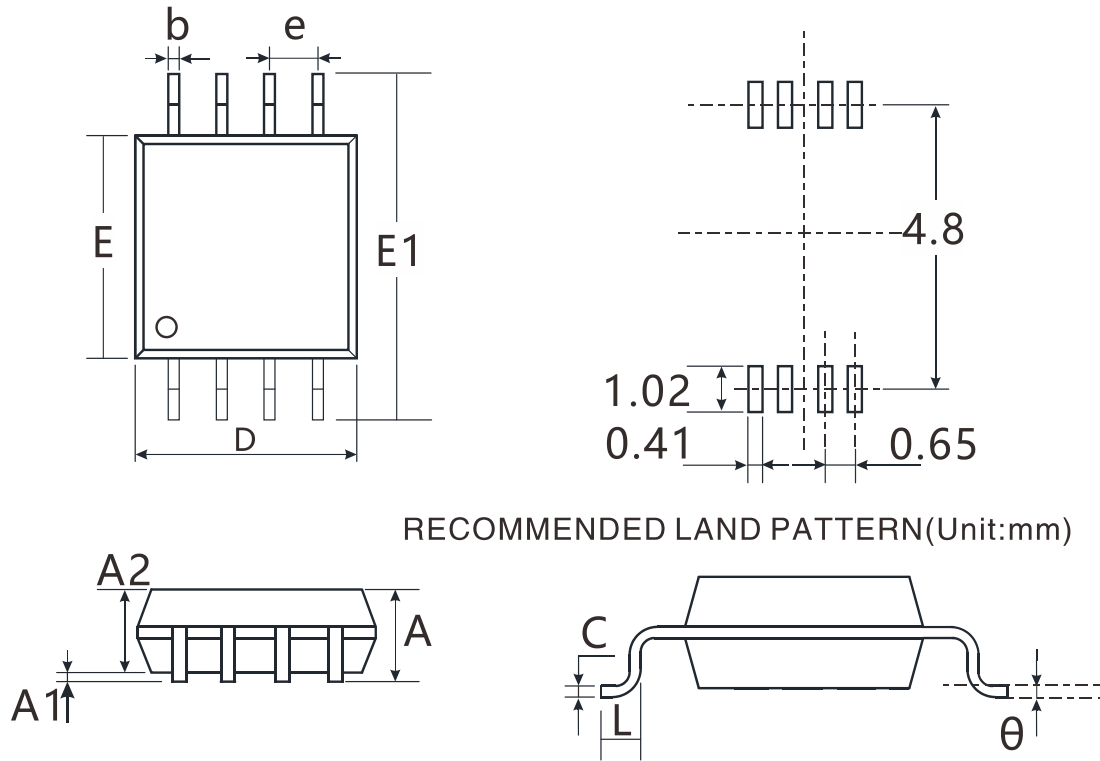

Figure 6. Typical video driving

Package Outline Dimensions

MSOP-8



Symbol	Dimensions In Millimeters		Dimensions Inches	
	Min	Max	Min	Max
A	0.820	1.100	0.032	0.043
A1	0.020	0.150	0.001	0.006
A2	0.750	0.950	0.030	0.037
b	0.250	0.380	0.010	0.015
c	0.090	0.230	0.004	0.009
D	2.900	3.100	0.114	0.122
E	2.900	3.100	0.114	0.122
E1	4.750	5.050	0.187	0.199
e	0.650 BSC		0.026 BSC	
L	0.400	0.800	0.016	0.031
θ	0°	6°	0°	6°

TSSOP-14

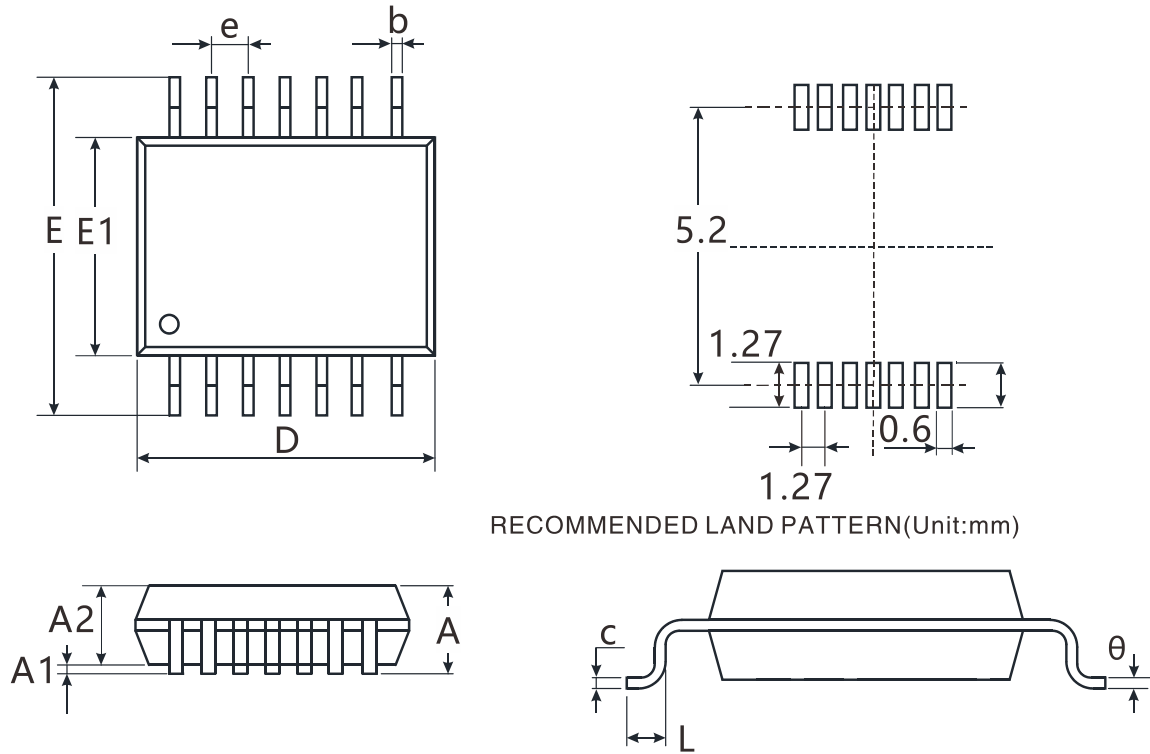

Symbol	Dimensions In Millimeters		Dimensions Inches	
	Min	Max	Min	Max
A		1.200		0.047
A1	0.050	0.150	0.002	0.006
A2	0.800	1.050	0.031	0.041
b	0.190	0.300	0.007	0.012
c	0.090	0.200	0.004	0.008
D	4.860	5.100	0.191	0.201
E	4.300	4.500	0.169	0.177
E1	6.250	6.550	0.246	0.258
e	0.650 BSC		0.026 BSC	
L	0.500	0.700	0.020	0.028
H	0.25 TYP		0.01 TYP	
θ	1°	7°	1°	7°

SOIC-8(SOP8)

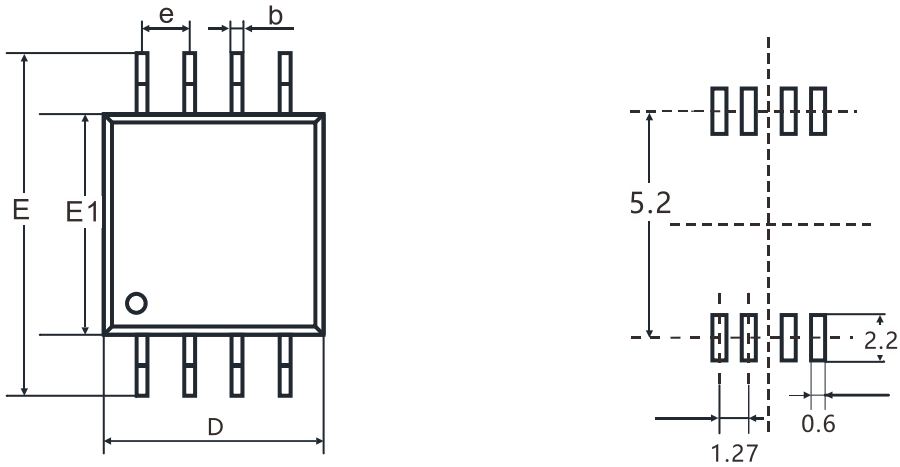

RECOMMENDED LAND PATTERN(Unit:mm)

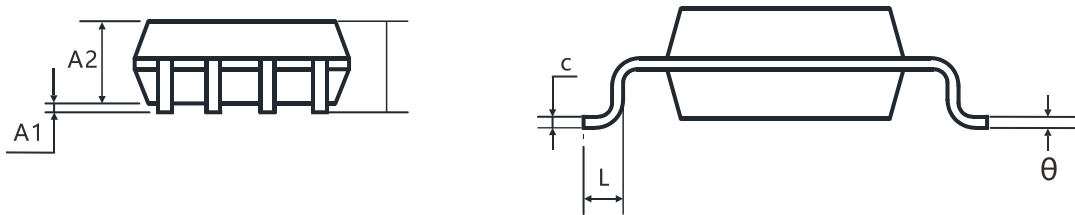

Symbol	Dimensions In Millimeters		Dimensions Inches	
	Min	Max	Min	Max
A	1.350	1.750	0.053	0.069
A1	0.100	0.250	0.004	0.010
A2	1.350	1.550	0.053	0.061
b	0.330	0.510	0.013	0.020
c	0.170	0.250	0.007	0.010
D	4.800	5.000	0.189	0.197
E	5.800	6.200	0.228	0.244
E1	3.800	4.000	0.150	0.157
e	1.270 BSC		0.050 BSC	
L	0.400	1.270	0.016	0.050
θ	0°	8°	0°	8°

SOIC-14(SOP14)

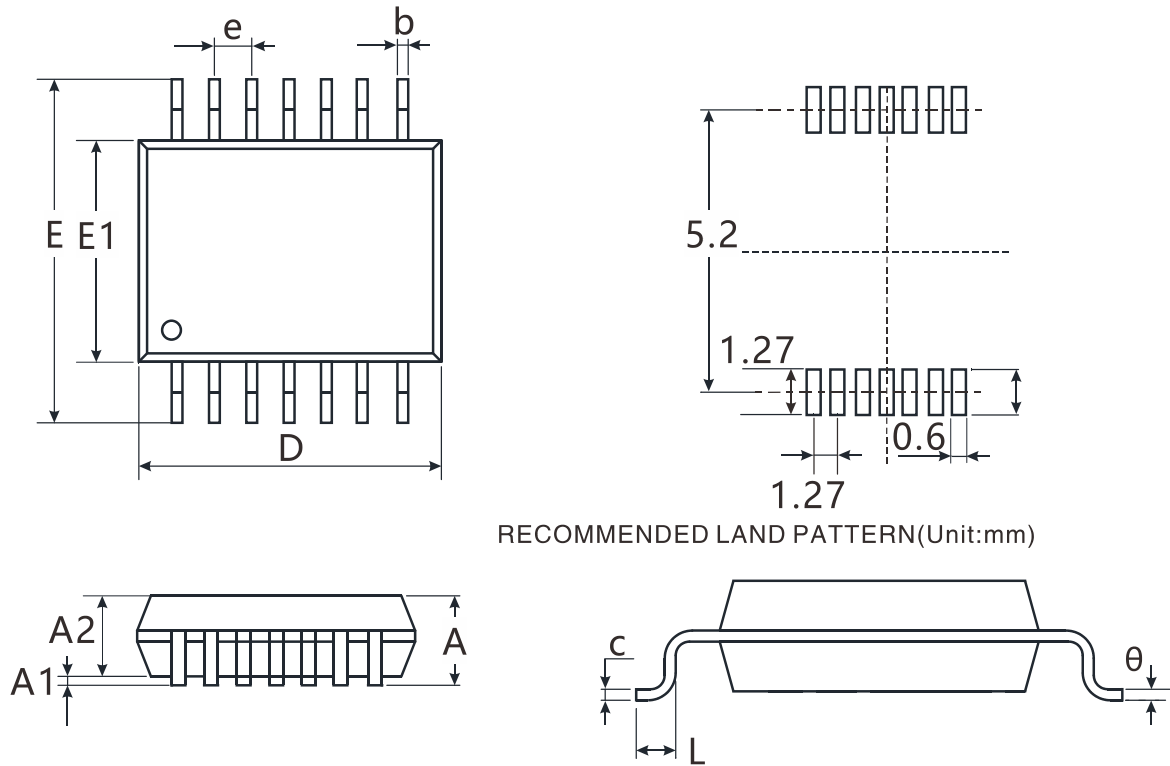

Symbol	Dimensions In Millimeters		Dimensions Inches	
	Min	Max	Min	Max
A	1.350	1.750	0.053	0.069
A1	0.100	0.250	0.004	0.010
A2	1.350	1.550	0.053	0.061
b	0.310	0.510	0.012	0.020
c	0.100	0.250	0.004	0.010
D	8.450	8.850	0.333	0.348
E	5.800	6.200	0.228	0.244
E1	3.800	4.000	0.150	0.157
e	1.270 BSC		0.050 BSC	
L	0.400	1.270	0.016	0.050
R1	0°	8°	0°	8°

SOT23-5

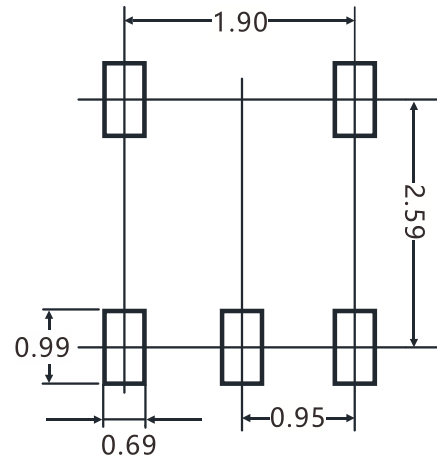
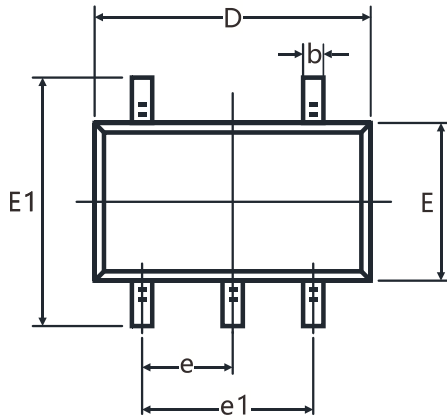

RECOMMENDED LAND PATTERN(Unit:mm)

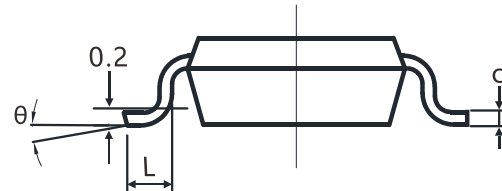
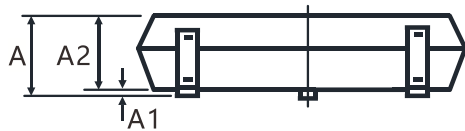

Symbol	Dimensions In Millimeters		Dimensions Inches	
	Min	Max	Min	Max
A	1.050	1.250	0.041	0.049
A1	0.000	0.100	0.000	0.004
A2	1.050	1.150	0.041	0.045
b	0.300	0.500	0.012	0.020
c	0.100	0.200	0.004	0.008
D	2.820	3.020	0.111	0.119
E	1.500	1.700	0.059	0.067
E1	2.650	2.950	0.104	0.116
e	0.950 BSC		0.037 BSC	
e1	1.800	2.000	0.071	0.079
L	0.300	0.600	0.012	0.024
θ	0°	8°	0°	8°

SC70-5

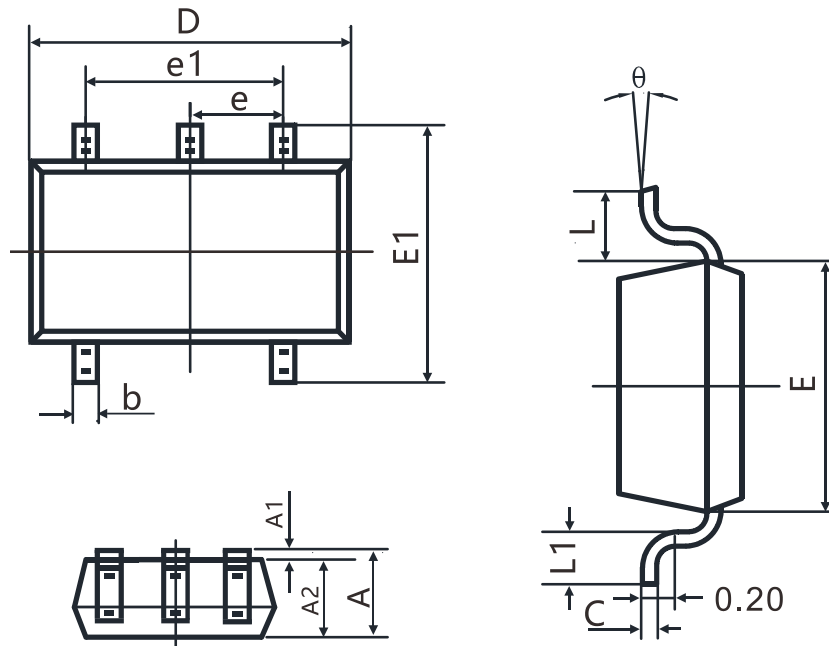

Symbol	Dimensions In Millimeters		Dimensions Inches	
	Min	Max	Min	Max
A	0.900	1.100	0.035	0.043
A1	0.000	0.100	0.000	0.004
A2	0.900	1.000	0.035	0.039
b	0.150	0.350	0.006	0.014
C	0.080	0.150	0.003	0.006
D	2.000	2.200	0.079	0.087
E	1.150	1.350	0.045	0.053
E1	2.150	2.450	0.085	0.096
e	0.650 TYP		0.026 TYP	
e1	1.200	1.400	0.047	0.055
L	0.525 REF		0.021 REF	
L1	0.260	0.460	0.010	0.018
θ	0°	8°	0°	8°

SOT23-6

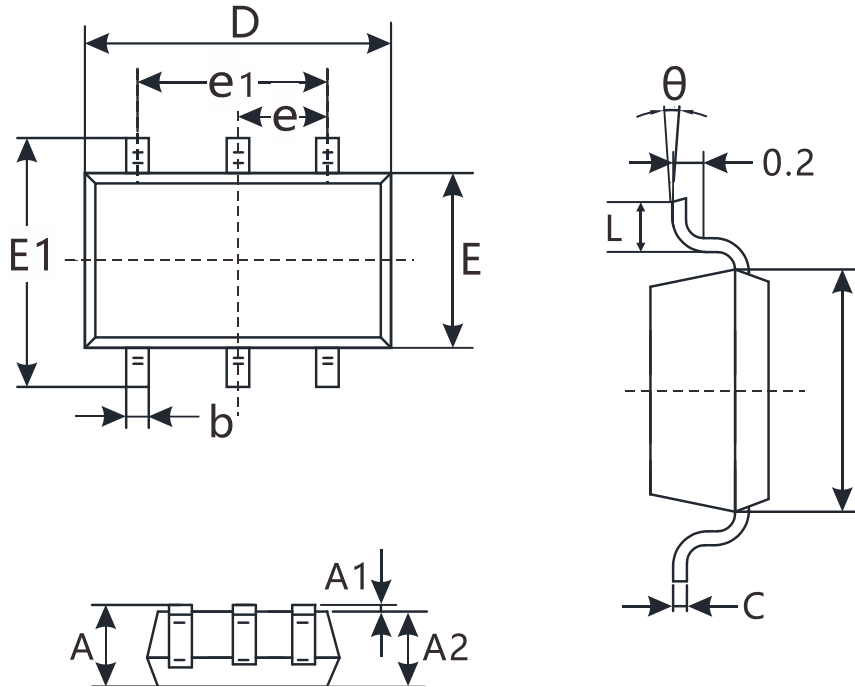

Symbol	Dimensions In Millimeters		Dimensions Inches	
	Min	Max	Min	Max
A	1.050	1.250	0.041	0.049
A1	0.000	0.100	0.000	0.004
A2	1.050	1.150	0.041	0.045
b	0.300	0.500	0.012	0.020
C	0.100	0.200	0.004	0.008
D	2.820	3.020	0.111	0.119
E	1.500	1.700	0.059	0.067
E1	2.650	2.950	0.104	0.116
e	0.950 BSC		0.037 BSC	
e1	1.900 BSC	0.075 BSC		
L	0.300		0.600	
θ	0°	8°	0°	8°

MSOP-10

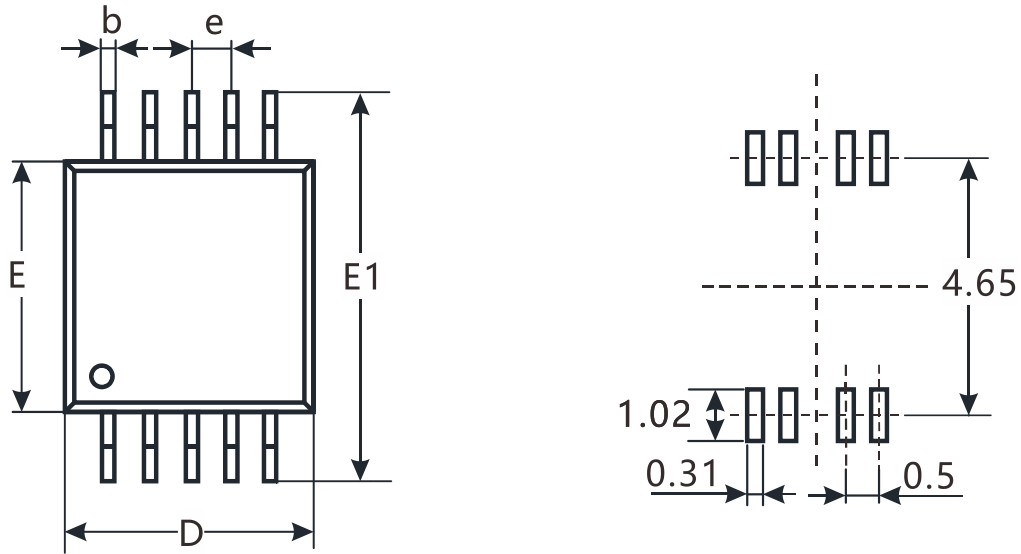

RECOMMENDED LAND PATTERN(Unit:mm)

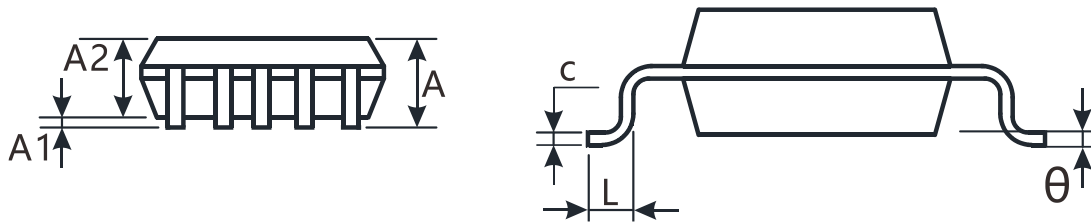

Symbol	Dimensions In Millimeters		Dimensions Inches	
	Min	Max	Min	Max
A	0.820	1.100	0.032	0.043
A1	0.020	0.150	0.001	0.006
A2	0.750	0.950	0.030	0.037
b	0.180	0.280	0.007	0.011
c	0.090	0.230	0.004	0.009
D	2.900	3.100	0.114	0.122
E	2.900	3.100	0.114	0.122
E1	4.750	5.050	0.187	0.199
e	0.50 BSC		0.020 BSC	
L	0.400	0.800	0.016	0.031
θ	0°	6°	0°	6°

Package/Ordering Information

MODEL	CHANNEL	ORDER NUMBER	PACKAGE DESCRIPTION	PACKAGE OPTION	MARKING INFORMATION
CBM8051	Single	CBM8051AC5	SC70-5	Tape and Reel,3000	H06
		CBM8051AST5	SOT23-5	Tape and Reel,3000	H06
CBM8052	Dual	CBM8052AS8	SOP-8	Tape and Reel,4000	CBM8052
		CBM8052AMS8	MSOP-8	Tape and Reel,3000	AFP
CBM8054	Quad	CBM8054ATS14	TSSOP-14	Tape and Reel,3000	CBM8054
		CBM8054AS14	SOP-14	Tape and Reel,2500	CBM8054
CBM8051N	Single With shutdown	CBM8051NC6	SC70-6	Tape and Reel,3000	H06N
		CBM8051NST6	SOT23-6	Tape and Reel,3000	H06N
CBM8052N	Dual With shutdown	CBM8052NMS10	MSOP-10	Tape and Reel,2500	CBM8052N