

SB2P50-41

2.0AMPS. SCHOTTKY BARRIER RECTIFIERS

FEATURE

- . High current capability
- . Low forward voltage drop
- . Low power loss, high efficiency
- . High surge capability
- . High temperature soldering guaranteed
260°C /1 0sec/0.375" lead length at 5 lbs tension

MECHANICAL DATA

- . Terminal: Plated axial leads solderable per MIL-STD 202E, method 208C
- . Case: Molded with UL-94 Class V-0 recognized Flame Retardant Epoxy
- . Polarity: color band denotes cathode
- . Mounting position: any

DO-41

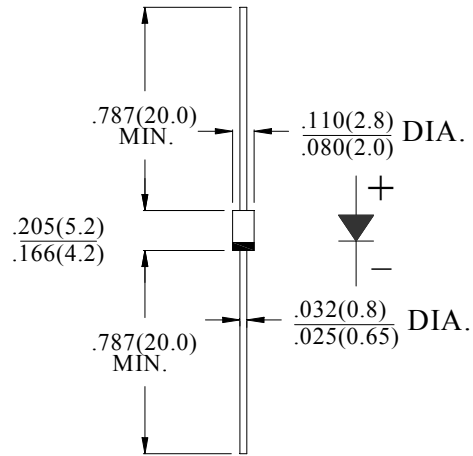

Dimensions in inches and (millimeters)

MAXIMUM RATINGS AND ELECTRICAL CHARACTERISTICS

Ratings at 25°C ambient temperature unless otherwise specified.
Single phase, half wave, 60Hz, resistive or inductive load.
For capacitive load, derate current by 20%

Type Number	SYM BOL	SB2P50-41	units
Maximum Recurrent Peak Reverse Voltage	V_{RRM}	50	V
Maximum RMS Voltage	V_{RMS}	35	V
Maximum DC blocking Voltage	V_{DC}	50	V
Maximum Average Forward Rectified Current .375"(9.5mm) lead length at $T_L = 90^\circ C$	$I_{F(AV)}$	2.0	A
Peak Forward Surge Current 8.3ms single half sine-wave superimposed on rated load (JEDEC method)	I_{FSM}	50	A
Maximum Forward Voltage @ $T_j = 25^\circ C$	at 2.0A DC	$V_{F Max}$	V
	at 0.5A DC	$V_{F Type}$	
Maximum DC Reverse Current at rated DC blocking voltage	@ $T_j = 25^\circ C$	I_R	mA
	@ $T_j = 100^\circ C$		
Typical Junction Capacitance (Note1)	C_J	72	pF
Typical Thermal Resistance (Note2)	$R_{(JA)}$	75	$^\circ C/W$
	$R_{(JC)}$	10	
Storage Temperature	T_{STG}	-55 to +150	$^\circ C$
Operating Junction Temperature	T_J	-55 to +150	$^\circ C$

Note:

1. Measured at 1.0 MHz and applied reverse voltage of 4.0Vdc
2. Thermal Resistance from Junction to Ambient at 0.375"(9.5mm)lead length, vertical P.C. Board Mounted

RATING AND CHARACTERISTIC CURVES (SB2P50-41)

FIG.1-TYPICAL FORWARD CURRENT DERATING CURVE

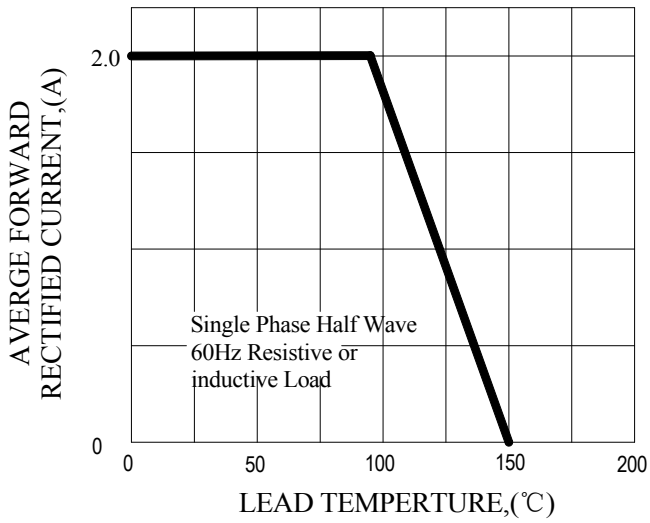

FIG.2-TYPICAL INSTANTANEOUS FORWARD CHARACTERISTICS

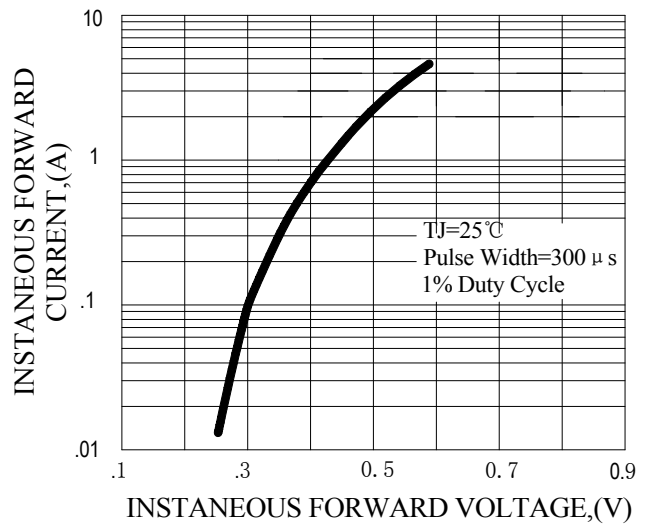

FIG.3-MAXIMUM NON-REPETITIVE FORWARD SURGE CURRENT

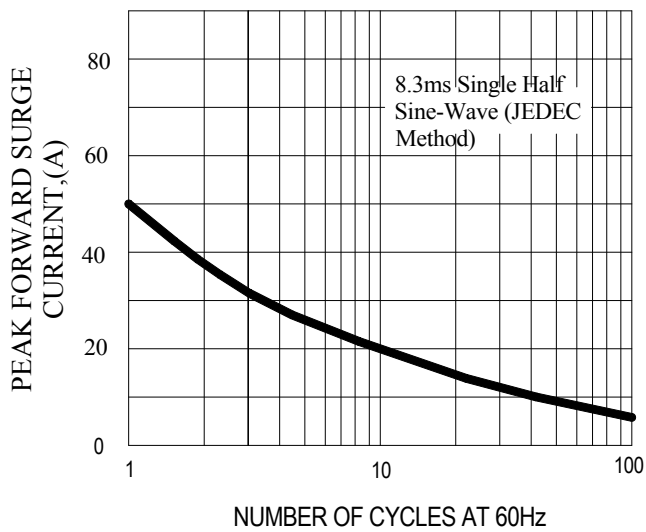
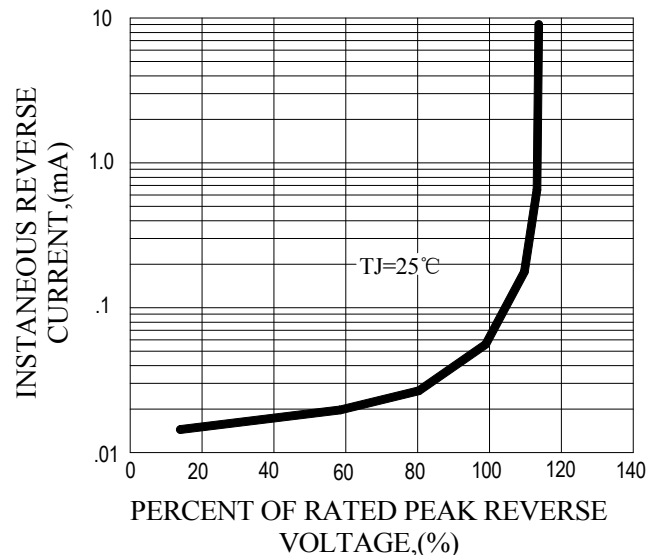
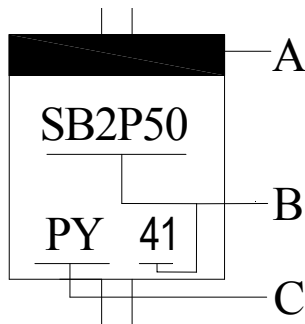

FIG.4-TYPICAL REVERSE CHARACTERISTICS



Marking and packaging illustration

1、Marking



SYMBOL	Explanation
A	Color Band Denotes Cathode
B	Product Name
C	Trademark

2、Packaging

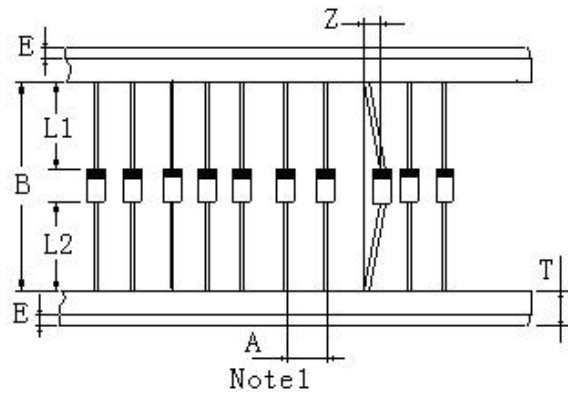

ITEM	SYMBOL	SPECIFICATIONS	
		(mm)	(inch)
Component alignment	Z	1.2max	0.048max
Tape width	T	6.0±0.4	0.2±0.016
Exposed adhesive	E	0.8max	0.032max
Body eccentricity	L1-L2	1.0max	0.040max
Component	A	5.0±0.5	0.2±0.02
Inner tap	B	52.0~53.5	2.06~2.11
NOTE: Each component lead shall be sandwiched between tapes for a minimum of 2.5mm (0.1inch)			