

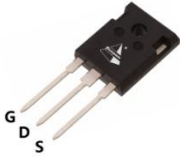

N-channel Power MOSFET

| PRODUCT SUMMARY | | |
|--|--------------|------|
| V_{DS} (V) at T_J max. | 700 | |
| $R_{DS(on)}$ max. at 25°C (Ω) | $V_{GS}=10V$ | 0.28 |
| Q_g max. (nC) | 160 | |
| Q_{gs} (nC) | 31 | |
| Q_{gd} (nC) | 52 | |
| Configuration | single | |



TO-247

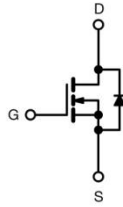

Schematic diagram

Features

- $I_D=22A(V_{GS}=10V)$
- Ultra Low Gate Charge
- Improved dv/dt Capability
- 100% Avalanche Tested
- $R_{\theta HS}$ compliant

Applications

- Switching Mode Power Supplies (SMPS)
- PWM Motor Controls
- DC to DC Converters
- LED Lighting
- Bridge Circuits

| ORDERING INFORMATION | |
|----------------------|-----------|
| Device | SPA22N65G |
| Device Package | TO-247 |
| Marking | 22N65G |

| ABSOLUTE MAXIMUM RATINGS ($T_C = 25^\circ C$, unless otherwise noted) | | | |
|---|----------------|-------------------|------|
| Parameter | Symbol | Limit | Unit |
| | | SPA22N65G | |
| Drain to Source Voltage | V_{DSS} | 650 | V |
| Continuous Drain Current (@ $T_C=25^\circ C$) | I_D | 22 ⁽¹⁾ | A |
| Continuous Drain Current (@ $T_C=100^\circ C$) | | 14 ⁽¹⁾ | A |
| Drain current pulsed ⁽²⁾ | I_{DM} | 88 ⁽¹⁾ | A |
| Gate to Source Voltage | V_{GS} | ± 30 | V |
| Single pulsed Avalanche Energy ⁽³⁾ | E_{AS} | 1452 | mJ |
| Peak diode Recovery dv/dt ⁽⁴⁾ | dv/dt | 6 | V/ns |
| Total power dissipation (@ $T_C=25^\circ C$) | P_D | 280 | W |
| Derating Factor above 25°C | | 2.2 | W/°C |
| Operating Junction Temperature & Storage Temperature | T_{STG}, T_J | -55 to + 150 | °C |
| Maximum lead temperature for soldering purpose | T_L | 260 | °C |

Notes

1. Drain current is limited by maximum junction temperature.
2. Repetitive rating : pulse width limited by junction temperature.
3. $L = 6mH, I_{AS} = 22A, V_{DD} = 50V, R_G=25\Omega$, Starting at $T_J = 25^\circ C$
4. $I_{SD} \leq I_D, di/dt = 100A/us, V_{DD} \leq BV_{DSS}$, Starting at $T_J = 25^\circ C$



| THERMAL CHARACTERISTICS | | | |
|---|------------|-------|------|
| Parameter | Symbol | Value | Unit |
| Thermal resistance, Junction to case | R_{thjc} | 0.44 | °C/W |
| Thermal resistance, Junction to ambient | R_{thja} | 38 | °C/W |

| ELECTRICAL CHARACTERISTICS ($T_C = 25^\circ\text{C}$ unless otherwise specified) | | | | | | |
|--|--------------------------------|---|------|------|------|----------|
| Parameter | Symbol | Test conditions | Min. | Typ. | Max. | Unit |
| Off Characteristics | | | | | | |
| Drain to source breakdown voltage | BV_{DSS} | $V_{GS}=0V, I_D=250\mu A$ | 650 | -- | -- | V |
| Breakdown voltage temperature coefficient | $\Delta BV_{DSS} / \Delta T_J$ | $I_D=250\mu A$, referenced to 25°C | -- | 0.49 | -- | V/°C |
| Drain to source leakage current | I_{DSS} | $V_{DS}=650V, V_{GS}=0V$ | -- | -- | 1 | μA |
| | | $V_{DS}=520V, T_C=125^\circ\text{C}$ | -- | -- | 50 | μA |
| Gate to source leakage current, forward | I_{GSS} | $V_{GS}=30V, V_{DS}=0V$ | -- | -- | 100 | nA |
| Gate to source leakage current, reverse | | $V_{GS}=-30V, V_{DS}=0V$ | -- | -- | -100 | nA |
| On Characteristics | | | | | | |
| Gate threshold voltage | $V_{GS(TH)}$ | $V_{DS}=V_{GS}, I_D=250\mu A$ | 2 | -- | 4 | V |
| Drain to source on state resistance | $R_{DS(ON)}$ | $V_{GS}=10V, I_D=11A$ | -- | 0.24 | 0.28 | Ω |
| Forward Transconductance | G_{fs} | $V_{DS}=30V, I_D=11A$ | -- | 22 | -- | S |
| Dynamic Characteristics | | | | | | |
| Input capacitance | C_{iss} | $V_{GS}=0V, V_{DS}=25V, f=1\text{MHz}$ | -- | 5220 | -- | pF |
| Output capacitance | C_{oss} | | -- | 463 | -- | |
| Reverse transfer capacitance | C_{rss} | | -- | 16 | -- | |
| Turn on delay time | $t_{d(on)}$ | $V_{DS}=380V, I_D=22A, R_G=25\Omega$ | -- | 73 | -- | ns |
| Rising time | t_r | | -- | 88 | -- | |
| Turn off delay time | $t_{d(off)}$ | | -- | 206 | -- | |
| Fall time | t_f | | -- | 78 | -- | |
| Total gate charge | Q_g | $V_{DS}=520V, V_{GS}=10V, I_D=22A$ | -- | 120 | 160 | nC |
| Gate-source charge | Q_{gs} | | -- | 31 | -- | |
| Gate-drain charge | Q_{gd} | | -- | 52 | -- | |

| SOURCE TO DRAIN DIODE RATINGS CHARACTERISTICS | | | | | | |
|---|----------|---|------|------|------|---------|
| Parameter | Symbol | Test conditions | Min. | Typ. | Max. | Unit |
| Continuous source current | I_S | Integral reverse p-n Junction diode in the MOSFET | -- | -- | 22 | A |
| Pulsed source current | I_{SM} | | -- | -- | 88 | A |
| Diode forward voltage drop. | V_{SD} | $I_S=22A, V_{GS}=0V$ | -- | -- | 1.3 | V |
| Reverse recovery time | T_{rr} | $I_S=22A, V_{GS}=0V, di_f/dt=100A/\mu s$ | -- | 520 | -- | ns |
| Reverse recovery Charge | Q_{rr} | | -- | 10 | -- | μC |



Fig1. Output characteristics

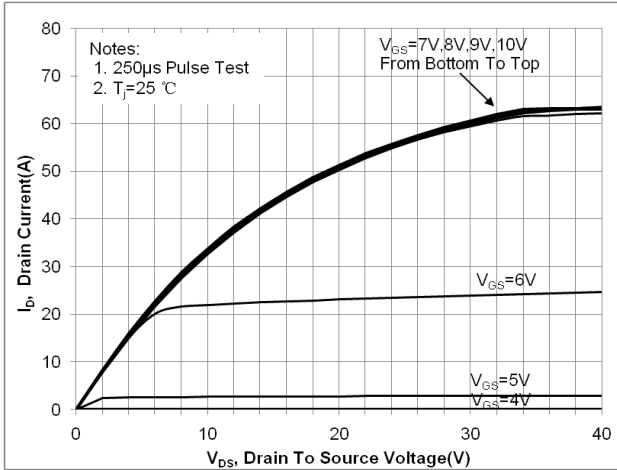

Fig2. Drain-source on-state resistance

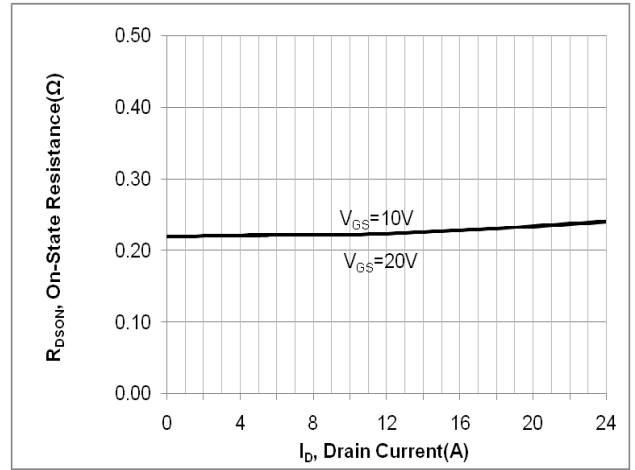

Fig3. Gate charge characteristics

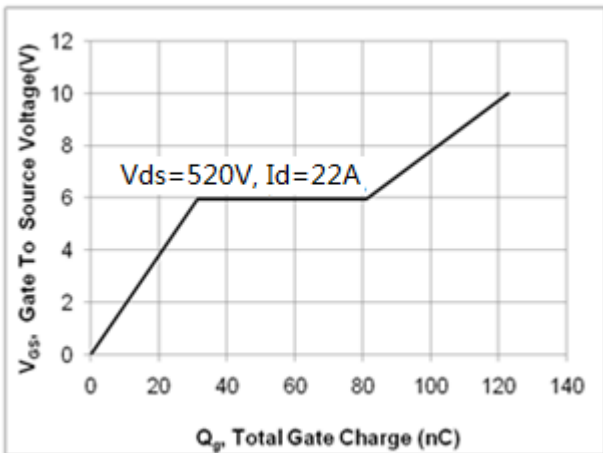

Fig 4. Capacitance Characteristics

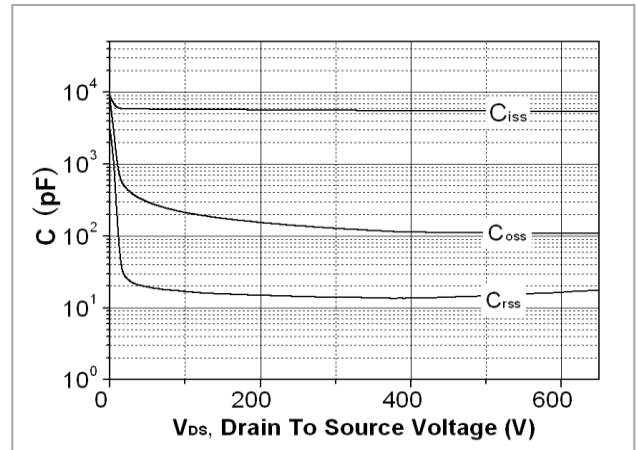

Fig 5. $R_{DS(ON)}$ vs junction temperature

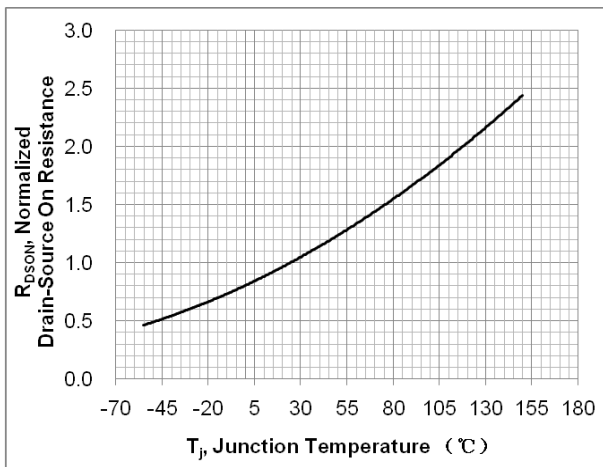

Fig 6. BV_{DSS} vs junction temperature

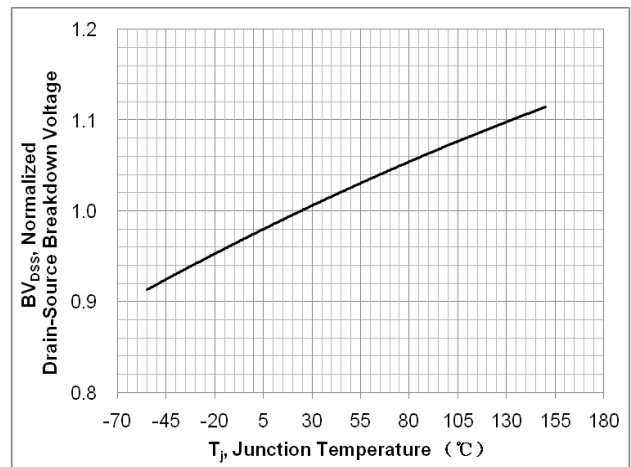

Fig 7 . Safe operating area

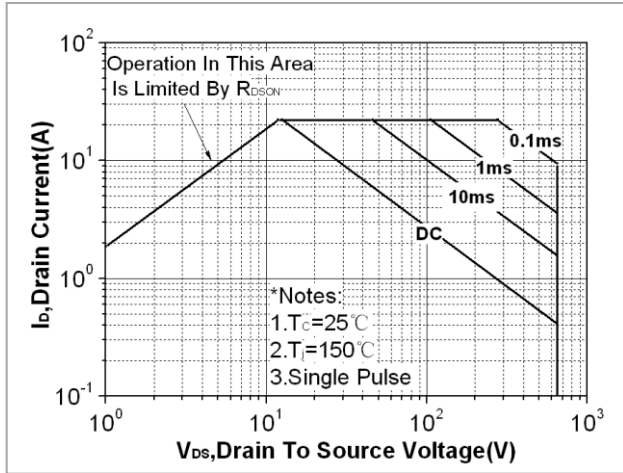

Fig 8 . Transient thermal impedance

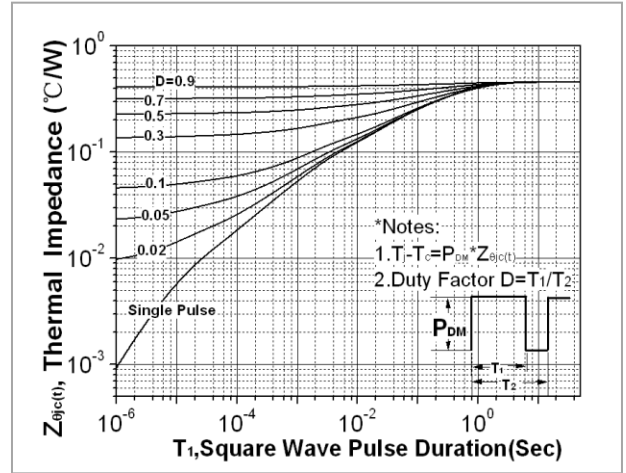

Fig 9. Forward characteristics of reverse diode

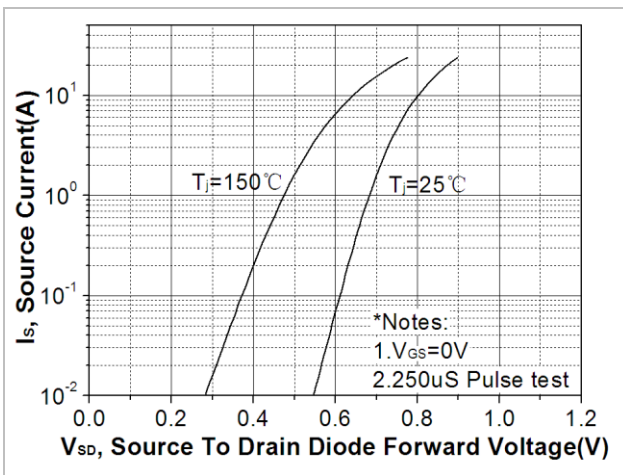

Fig 10. Gate charge test circuit & waveform

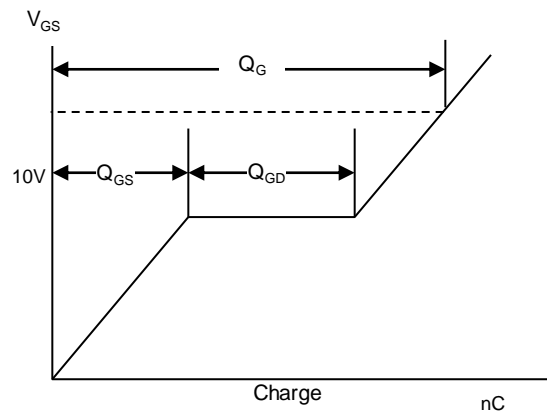
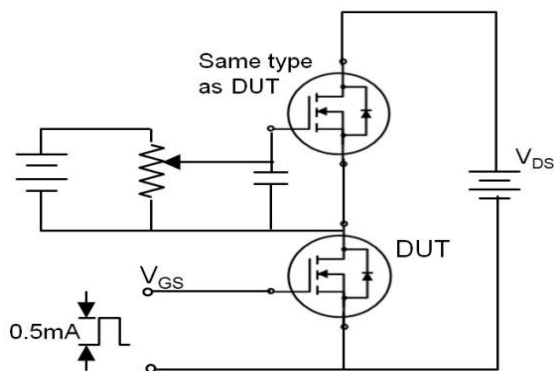

Fig 11. Switching time test circuit & waveform

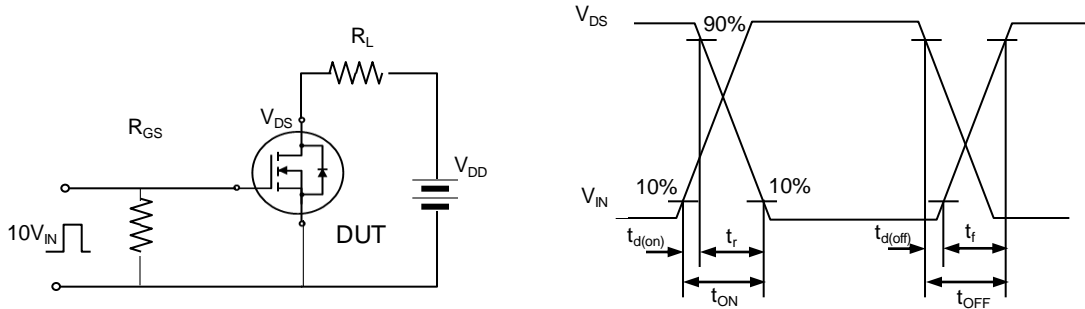

Fig 12. Unclamped Inductive switching test circuit & waveform

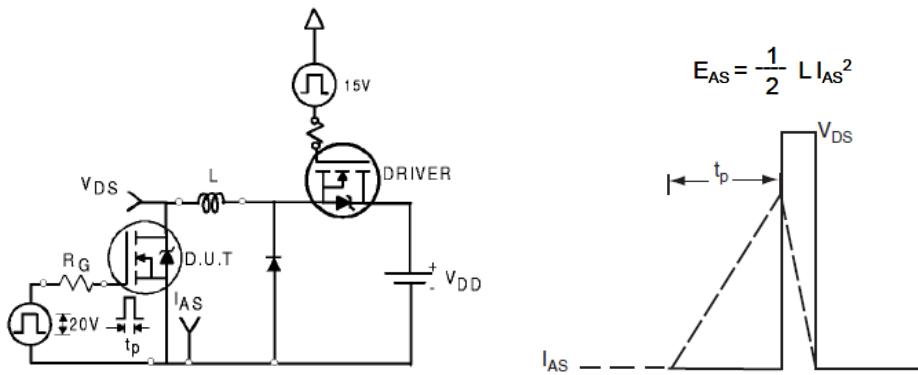
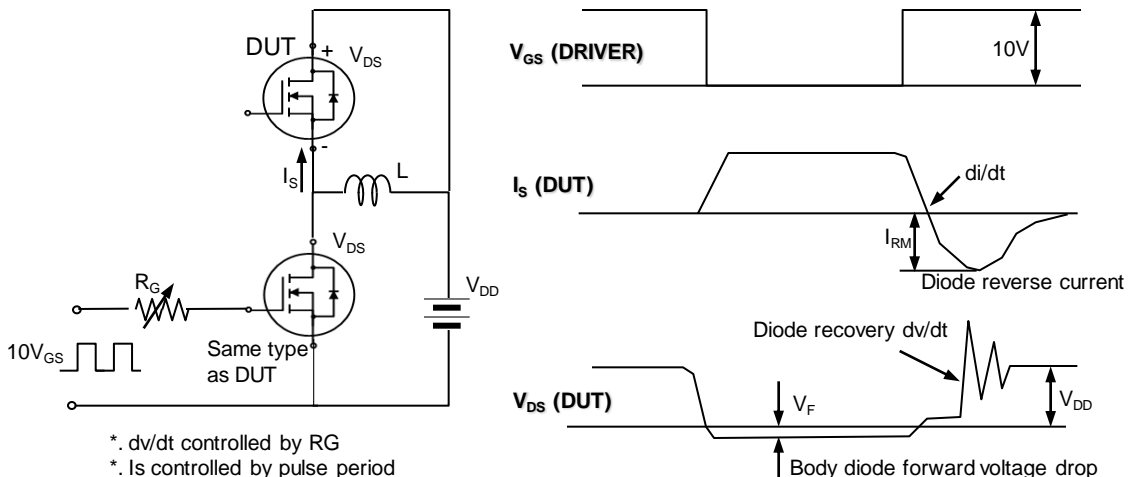

Fig 13. Peak diode recovery dv/dt test circuit & waveform





Disclaimer

- ◆ SINAI assumes no responsibility for equipment failures that result from using products at values that exceed, even momentarily, rated values (such as maximum ratings, operating condition ranges, or other parameters) listed in products specifications of any and all SINAI products described or contained herein.
- ◆ Specifications of any and all SINAI products described or contained herein stipulate the performance, characteristics, and functions of the described products in the independent state, and are not guarantees of the performance, characteristics, and functions of the described products as mounted in the customer's products or equipment. To verify symptoms and states that cannot be evaluated in an independent device, the customer should always evaluate and test devices mounted in the customer's products or equipment.
- ◆ In the event that any or all SINAI products (including technical data, services) described or contained herein are controlled under any of applicable local export control laws and regulations, such products must not be exported without obtaining the export license from the authorities concerned in accordance with the above law.
- ◆ This catalog provides information as of June, 2017. Specifications and information herein are subject to change without notice.