

DATA SHEET

SUNGMUN CODE : BSIL-10H
DESCRIPTION : SLIDE SWITCH

SUNGMUN ELECTRONICS CO., LTD.

Address 301-302, Bucheon Technopark 345, Seokcheon-ro, Ojeong-gu
Bucheon-si, Gyeonggi-do, Korea
TEL. +82-32-328-1941~4
FAX +82-32-328-1945
E-mail sungmun@sungmun.co.kr
Website www.sungmun.com

MARK	DATE	REMARKS
△		
△		

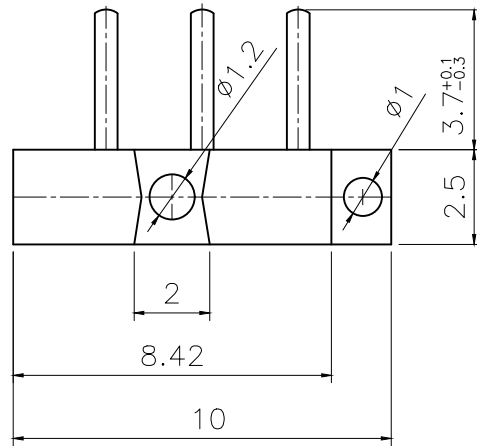

SPECIFICATION

1. Rating : 0.5A, DC 12V~0.3A, DC24V
2. Contact Resistance : 30mΩ Max
3. Travel : 1.6mm
4. Operating Force : 250gf ± 150gf
5. Life cycle : 2,000 Cycle(with load)

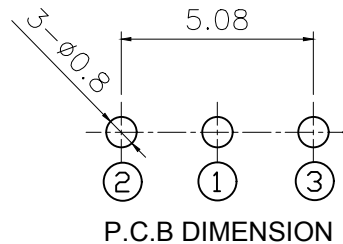
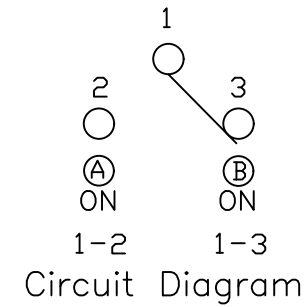
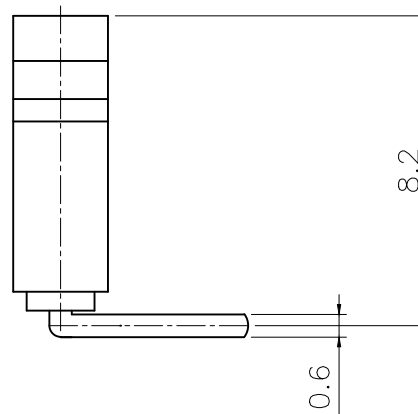
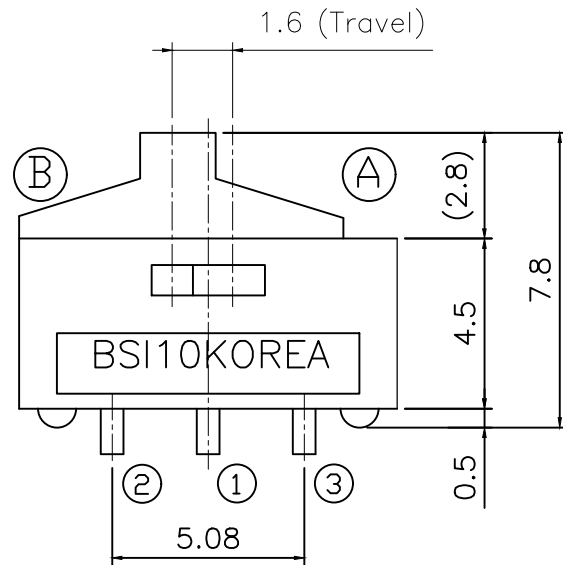

NO.	DWG No.	Q'TY	MAT'L	SPEC'	FINISH	REMARKS
3ANG	UNIT M/M	SCL	MODEL NAME. MINI SLIDE SWITCH			
APPD.	CHKD.	D'SGD	TITLE BSIL-10H			
K.I LEE	S.M PARK	W.J LEE	DRAWG. NO.		Sheet No. 1 / 2	REV C
SUNGMUN ELECTRONICS CO.,LTD						

1. Electrical Characteristics :

- 1-1 Rating : AC, DC 12V 0.5A ~ 24V 0.3A (Minimum current: 1mA)
- 1-2 Contact Resistance : Max 30mΩ
- 1-3 Insulation Resistance : Min 10,000 MΩ at DC 500V
- 1-4 Withstanding Voltage : 1min at AC 500V

2. Mechanical Characteristics :

- 2-1 Operating Force : 250 ± 150gf
- 2-2 Travel : 1.6mm
- 2-3 Insulator :
 - 2-3-1 Case : Glass Fiber resin
 - 2-3-2 Slide : Glass Fiber resin
- 2-4 Terminal : Nickel, Gold Plate

3. Life Test :

- 3-1 Test Condition : Operations at a rate of 15-20 cycles in 1 minute
 - 3-1-1 With load : 2,000 cycles
 - 3-1-2 Without load : 10,000 cycles
- 3-2 Operating Force : With +40%, -40% of Initial Value
- 3-3 Contact Resistance : Max 200mΩ

4. Environmental Characteristics :

- 4-1 Operating Temperature : -40°C to +85°C
- 4-2 Storage Temperature : -40°C to +85°C
- 4-3 Humidity Test :
 - 4-3-1 Test Conditions : Measured 1 hour after exposure to ambient
After 96 hours exposure at 40±2°C, 90-95%R.H
 - 4-3-2 Insulation Resistance : Min 100 MΩ at DC 500V
 - 4-3-3 Withstanding Voltage : 1 min at AC 250V

5. Solder Conditions :

- 5-1 Hand Solder : 3~4 sec. at 350°C
- 5-2 Wave Solder : 5 sec. at 260°C