

SYMB REVISIONS

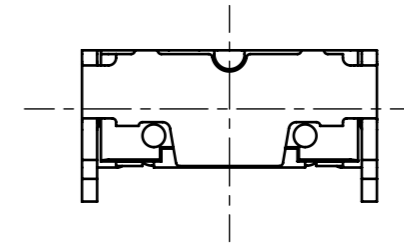

PRINTED WIRING BOARD LAND DIMENSION
 推奨ランド寸法
 (WHEN VIEWED FROM THE SWITCH MOUNTING FACE)
 (スイッチ取り付け面より見る)

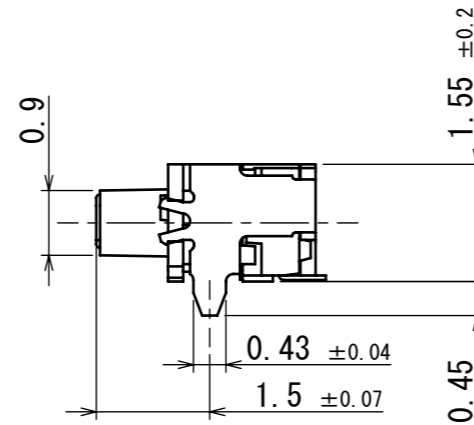
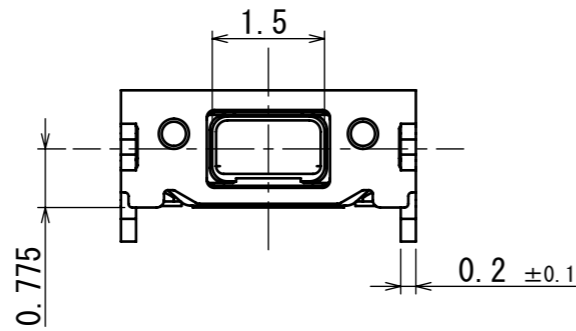
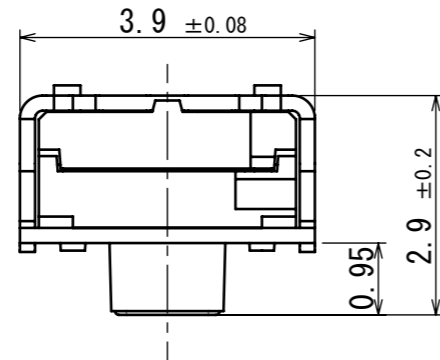
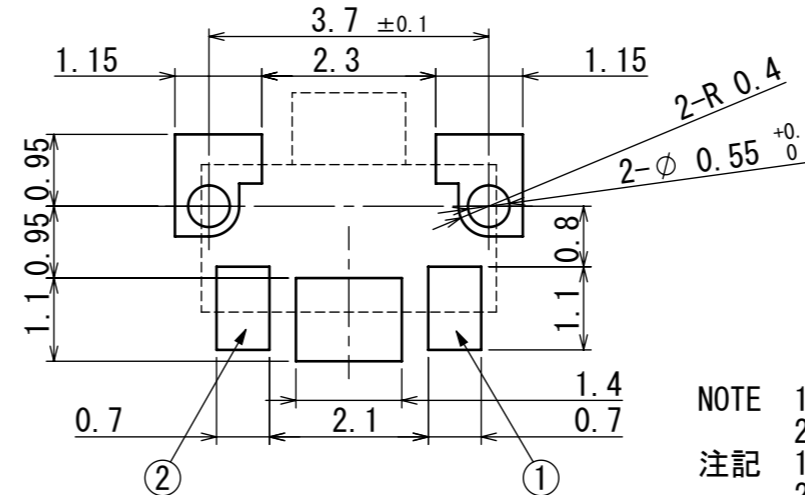
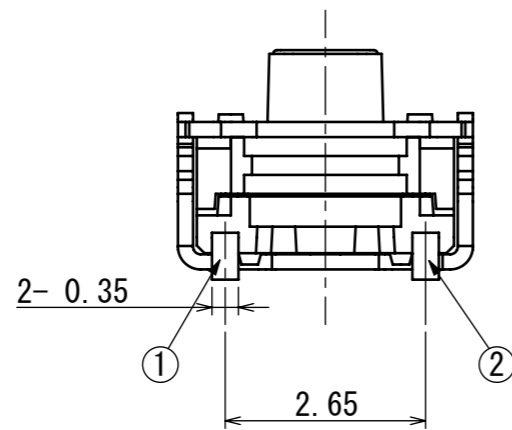

CIRCUIT DIAGRAM
 回路図

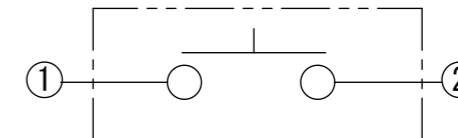

- NOTE 1. TAPING SPECIFICATION TO BE ACCORDANCE WITH TTD-901.
 2. ALL TERMINAL COPLANARITY: 0.08mm MAX.
 注記 1. テーピング包装仕様書は、TTD-901による。
 2. 端子コプラナリティ: 0.08mm以下。

TOLERANCES UNLESS OTHERWISE SPEC	
BASIC DIMENSIONS	TOLERANCES
UP TO 10	±0.3
ABOVE 10 TO 100	±0.5
ABOVE 100	±0.8
ANGULAR DIMENSION	±5°

PART NO.	NAME	SPEC	MATERIAL	FINISH
ALPS ELECTRIC CO., LTD.				
	DSGD. 2015.10.05 C EG3 DG1	SCALE	NO.	
	Y. ITO	10:1	SKTDLHE010	
	CHKD. 2015.10.05 C EG3 DG1	UNIT	TITLE	
	K. OZAWA		PRODUCT DRAWING (製品図)	
	APPD. 2015.10.05 C EG3 DG1	mm	DOCUMENT NO.	
	K. OZAWA		SKTDLHE010, 1100, 31	