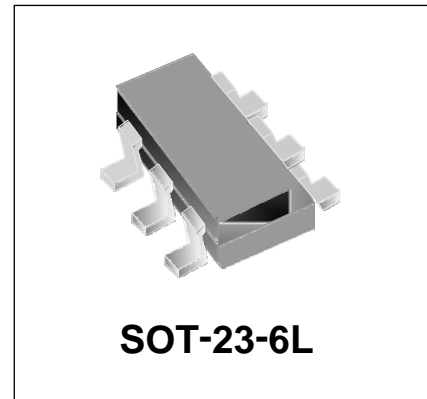


### Features

- Low operating voltage: 5V
- Low capacitance
- Solid-state silicon-avalanche and active circuit triggering technology
- Back-drive protection for power-down mode
- Lead-free version available



### IEC COMPATIBILITY (EN61000-4)

- IEC 61000-4-2 (ESD)  $\pm 25\text{kV}$  (air),  $\pm 25\text{kV}$  (contact)
- IEC 61000-4-4 (EFT) Level-3, 40A (5/50ns)
- IEC 61000-4-5 (Lightning) 3A (8/20 $\mu\text{s}$ )

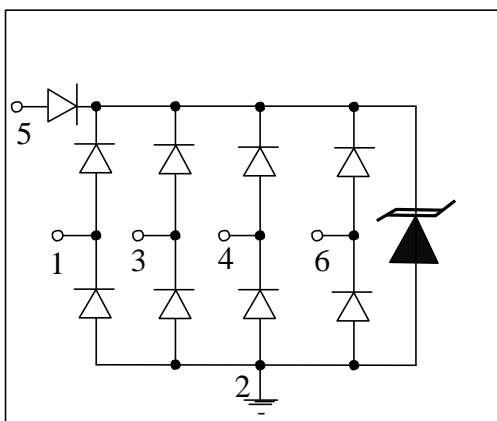
### Mechanical Characteristics

- SOT-23-6L package
- Molding compound flammability rating: UL 94V-0
- Marking: Marking Code
- Packaging: Tape and Reel
- RoHS Compliant

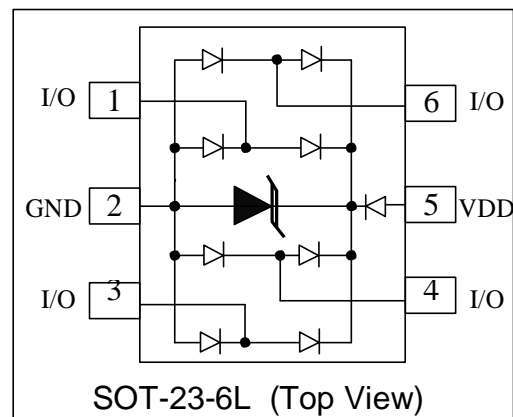
### Applications

- Video Graphics Cards
- Digital Visual Interface (DVI)
- USB2.0 Power and Data lines protection
- Notebook and PC Computers
- Monitors and Flat Panel Displays

### Circuit Diagram



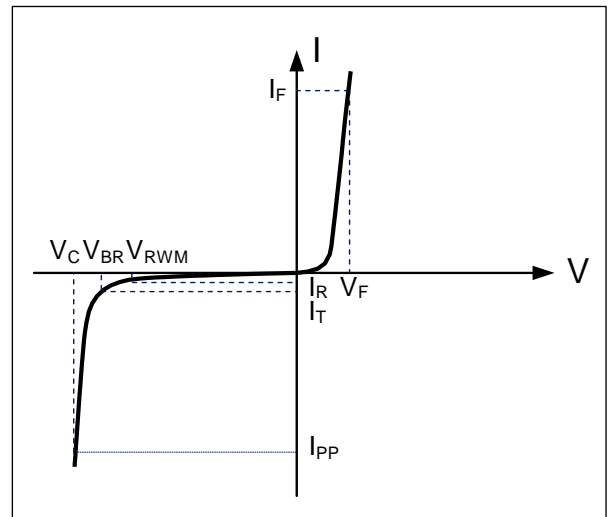
### Schematic & PIN Configuration



Absolute Maximum Rating			
Rating	Symbol	Value	Units
Peak Pulse Power ( $t_p=8/20\mu s$ )	$P_{PP}$	80	Watts
Peak Pulse Current ( $t_p=8/20\mu s$ )	$I_{PP}$	4	A
Operating Temperature	$T_J$	-55 to + 85	°C
Storage Temperature	$T_{STG}$	-55 to +150	°C

### Electrical Parameters (T=25°C)

Symbol	Parameter
$I_{PP}$	Maximum Reverse Peak Pulse Current
$V_C$	Clamping Voltage @ $I_{PP}$
$V_{RWM}$	Working Peak Reverse Voltage
$I_R$	Maximum Reverse Leakage Current @ $V_{RWM}$
$V_{BR}$	Breakdown Voltage @ $I_T$
$I_T$	Test Current
$I_F$	Forward Current
$V_F$	Forward Voltage @ $I_F$

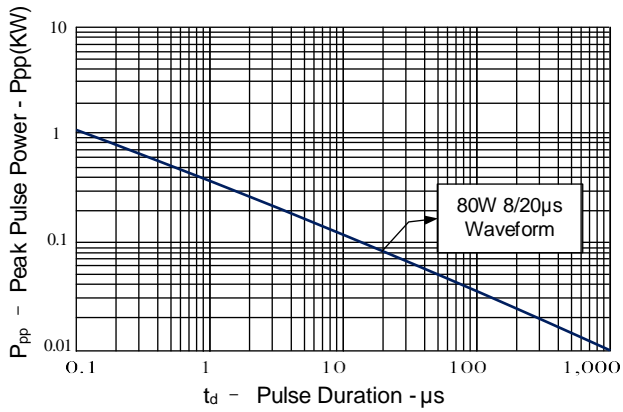


### Electrical Characteristics

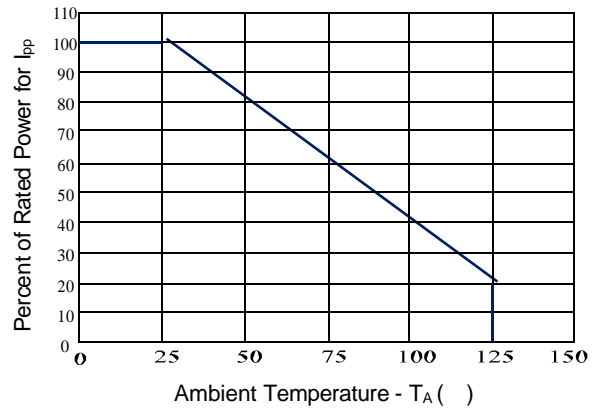
MST236A055L						
Parameter	Symbol	Conditions	Minimum	Typical	Maximum	Units
Reverse Stand-Off Voltage	$V_{RWM}$	Pin5 to pin 2 T=25°C			5.0	V
Reverse Breakdown Voltage	$V_{BR}$	$I_T=1mA$ Pin 5 to pin 2	6.0			V
		$I_T=1mA$ Pin 2 to pin 5	40			V
Reverse Leakage Current	$I_R$	$V_{RWM}=5V, T=25°C$ I/O pin to GND			500	nA
		$V_{RWM}=5V, T=25°C$ I/O pin to I/O pin			500	nA
Clamping Voltage	$V_C$	$I_{PP}=3A, t_p=8/20\mu s$ I/O pin to GND		20	25	V
Junction Capacitance	$C_j$	$V_R = 0V, f = 1MHz$ I/O pin to GND		2.0	3.0	pF
		$V_R = 0V, f = 1MHz$ Between I/O pins		1.0	2.0	pF

## Typical Characteristics

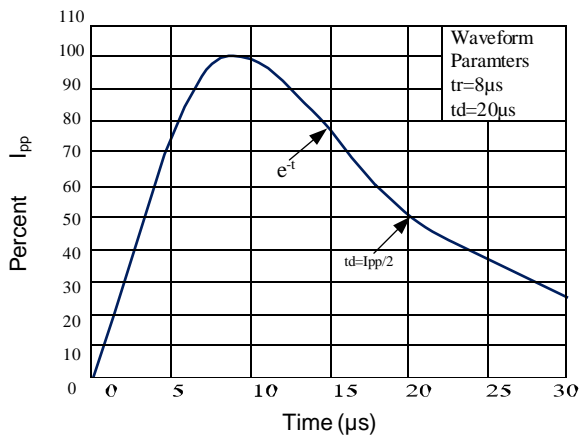
**Figure 1: Peak Pulse Power vs. Pulse Time**



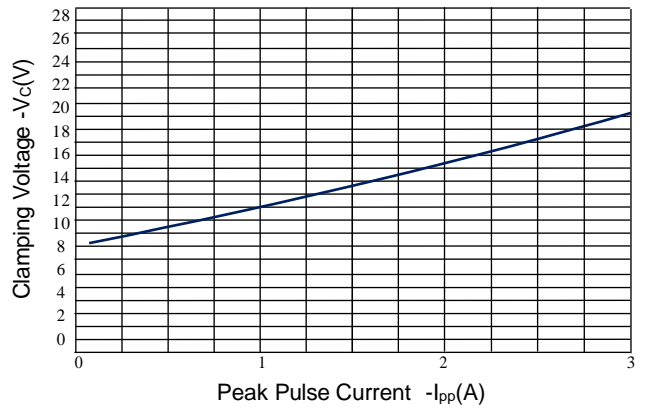
**Figure 2: Power Derating Curve**



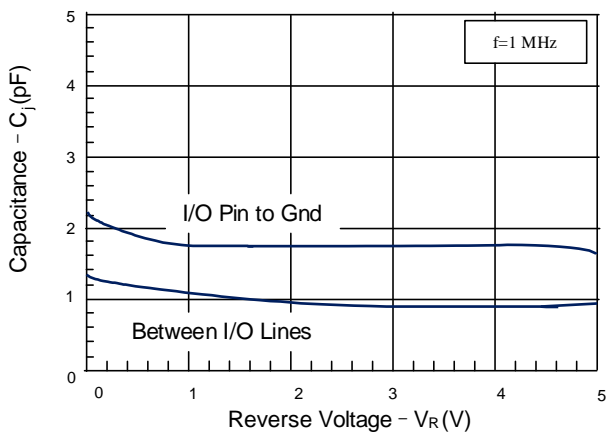
**Figure 3: Pulse Waveform**



**Figure 4: Clamping Voltage vs. Peak Pulse Current**

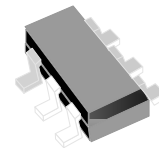
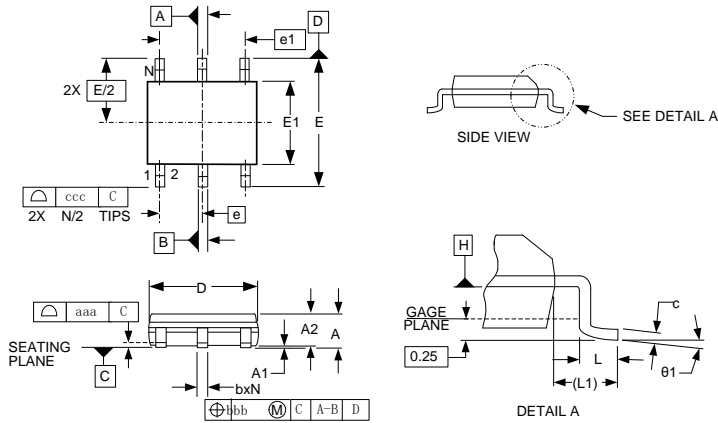


**Figure 5: Capacitance vs. Reverse Voltage**



### Outline Drawing – SOT-23-6L

#### PACKAGE OUTLINE



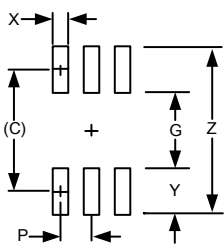
SOT-23-6L

#### DIMENSIONS

DIM	INCHES			MILLIMETERS		
	MIN	NOM	MAX	MIN	NOM	MAX
A	.035	-	.057	0.90	-	1.45
A1	.000	-	.006	0.00	-	0.15
A2	.035	.045	.051	0.90	1.15	1.30
b	.010	-	.020	0.25	-	0.50
c	.003	-	.009	0.08	-	0.22
D	.110	.114	.122	2.80	2.90	3.10
E1	.060	.063	.069	1.50	1.60	1.75
E	.110BSC			2.80 BSC		
e	.037 BSC			0.95 BSC		
e1	.075BSC			1.90 BSC		
L	.012	.018	.024	0.30	0.45	0.60
L1	(.024)			(0.60)		
θ 1	0°	-	10°	0°	-	10°
N	6			6		
aaa	.004			0.10		
bbb	.008			0.20		
ccc	.008			0.20		

#### NOTES:

1. Controlling Dimensions are In Millimeters (Angles In Degrees).
2. Datums **A** And **B** To Be Determined At Datum Plane **H**.
3. Dimensions "E1" And "D" Do Not Include Mold Flash, Protrusions Or Gate Burrs.



DIMENSIONS		
DIM	INCHES	MILLIMETERS
C	(.098)	(2.50)
G	.055	1.40
P	.037	0.95
X	.024	0.60
Y	.043	1.10
Z	.141	3.60

#### Notes

THIS LAND PATTERN IS FOR REFERENCE PURPOSES ONLY. CONSULT YOUR MANUFACTURING GROUP TO ENSURE YOUR COMPANY'S MANUFACTURING GUIDELINES ARE MET.

### Marking Codes

Part Number	MST236A055L
Marking Code	V5V

