

## PS8100LT

### 8.0AMPS. TRENCH SCHOTTKY BARRIER RECTIFIERS

#### FEATURE

- . For surface mounted application
- . High current capability
- . Low forward voltage drop
- . Low power loss, high efficiency
- . High surge current capability
- . High temperature soldering guaranteed:  
260°C/10 seconds at terminals.

#### MECHANICAL DATA

- . Terminal: Solder plated
- . Case: Molded with UL-94 Class V-0 recognized  
Flame Retardant Epoxy (Halogen free)

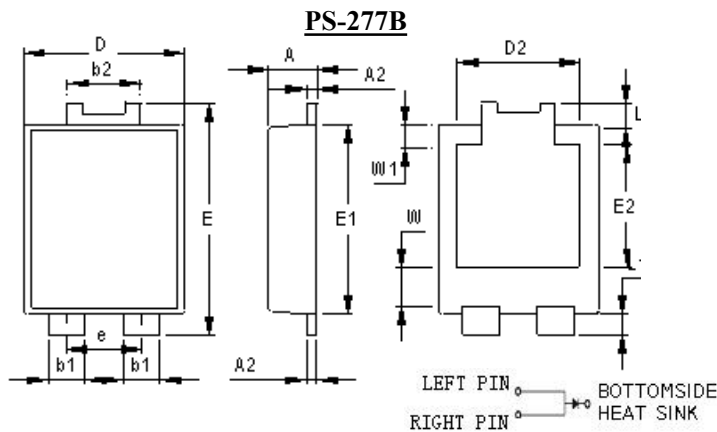

NO	Dimensions	NO	Dimensions
A	1.20±0.1	e	1.84Typ
A2	0.25±0.05	E1	5.3±0.1
b1	0.9±0.1	E2	3.3±0.2
b2	1.8±0.1	L	0.6±0.1
D	3.95±0.1	L1	0.6±0.1
D2	3.00Typ	W	1.3±0.2
E	6.5±0.1	W1	0.6±0.2

All Dimensions in mm

Single phase, half wave, 60Hz, resistive or inductive load.

For capacitive load, derate current by 20%

**MAXIMUM RATINGS** ( $T_C=25^\circ\text{C}$  unless otherwise noted)

Parameter	Symbol	PS8100LT	Units
Maximum Recurrent Peak Reverse Voltage	$V_{RRM}$	100	V
Maximum RMS Voltage	$V_{RMS}$	70	V
Maximum DC blocking Voltage	$V_{DC}$	100	V
Average Forward Rectified Current at $T_L \leq 100^\circ\text{C}$	$I_{F(AV)}$	8	A
Non-repetitive forward surge current, 8.3ms Half sine-wave	$I_{FSM}$	150	A
Typical Junction Capacitance (Note1)	$C_J$	800	pF
Operation Junction Temperature and Storage Temperature	$T_J, T_{STG}$	-55 to +150	$^\circ\text{C}$

**ELECTRICAL CHARACTERISTICS** ( $T_C=25^\circ\text{C}$  unless otherwise noted)

Parameter	Symbol	Min	Typ	Max	Units
Instantaneous Forward voltage at 10A	$V_F$	@ $T_J=25^\circ\text{C}$	-----	0.59	0.68
		@ $T_J=125^\circ\text{C}$	-----	0.54	-----
reverse current at rated DC blocking voltage	$I_R$	@ $T_J=25^\circ\text{C}$	-----	-----	0.1
		@ $T_J=125^\circ\text{C}$	-----	-----	20.0

**THERMAL CHARACTERISTICS** ( $T_C=25^\circ\text{C}$  unless otherwise noted)

Parameter	Symbol	PS8100LT	Units
Typical Thermal Resistance (Note2)	$R_{(JA)}$	45	$^\circ\text{C}/\text{W}$
	$R_{(JC)}$	15	

#### Note:

1.  $T_J=25^\circ\text{C}, V_R = 4V_{DC}@1\text{Mhz}$

2. Polyimide PCB, 2oz. Copper. Cathode pad dimensions 18.8\* 14.4\*1.6mm. Anode pad dimensions 5.6 x 14.4\*1.6mm.

**RATING AND CHARACTERISTIC CURVES (PS8100LT)**

FIG.1-TYPICAL FORWARD CURRENT DERATING CURVE

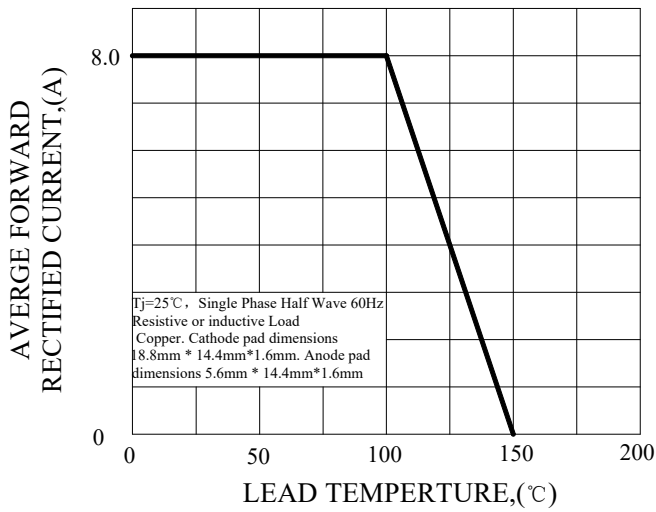

FIG.2-TYPICAL INSTANTANEOUS FORWARD CHARACTERISTICS

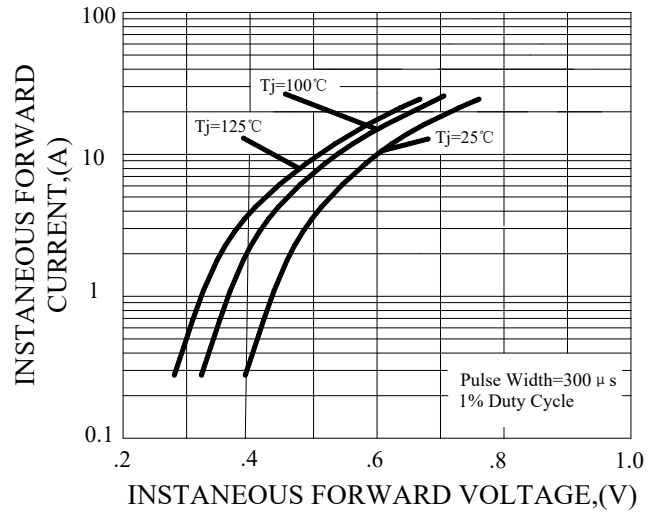

FIG.3-MAXIMUN NON-REPETITIVE FORWARD SURGE CURRENT

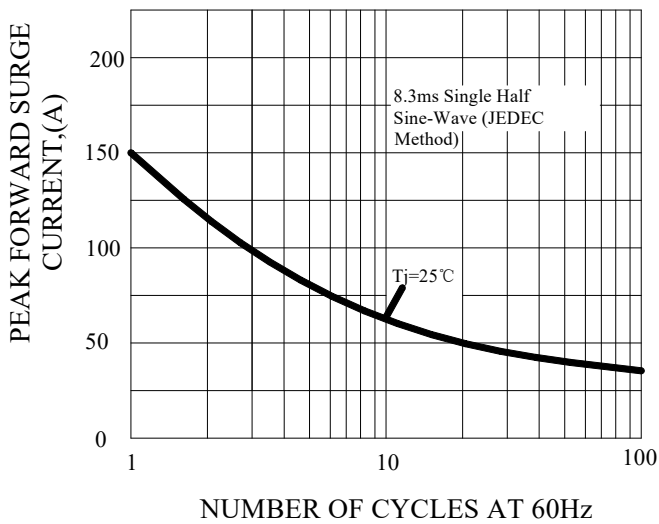

FIG.4-TYPICAL REVERSE CHARACTERISTICS

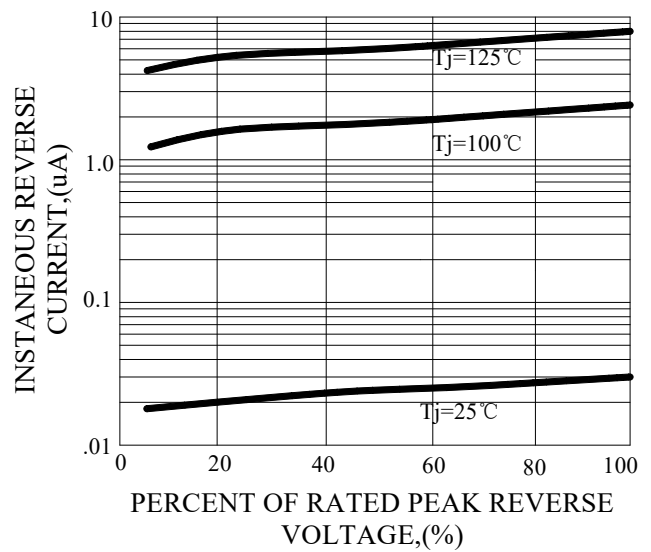
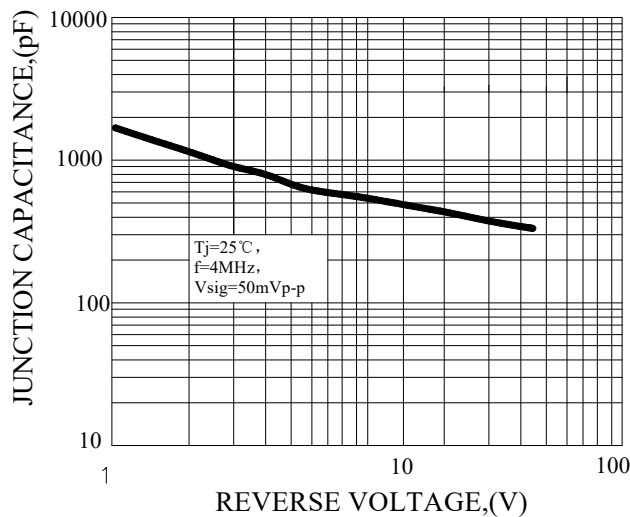
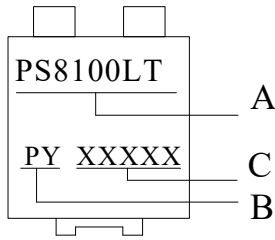

FIG.5-TYPICAL JUNCTION CAPACITANCE



## Marking、 Pad Layout 、 MOQ and Packaging illustration

### 1、 Marking



SYMBOL	Explanation
<b>A</b>	<b>Product Name</b>
<b>B</b>	<b>Trademark</b>
<b>C</b>	<b>Date Code</b>

### 2、 Suggested Pad Layout

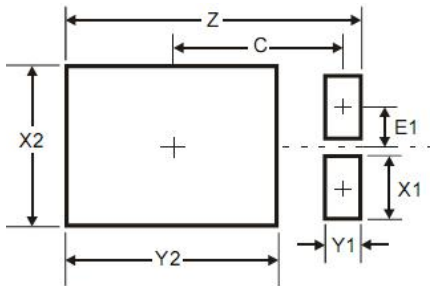

Dimensions	Value (in mm)
<b>Z</b>	<b>6.6</b>
<b>X1</b>	<b>1.4</b>
<b>X2</b>	<b>3.6</b>
<b>Y1</b>	<b>0.8</b>
<b>Y2</b>	<b>4.7</b>
<b>C</b>	<b>3.87</b>
<b>E1</b>	<b>0.9</b>

### 3、 MOQ

3000pcs / Tape & Reel

### 4、 Packaging

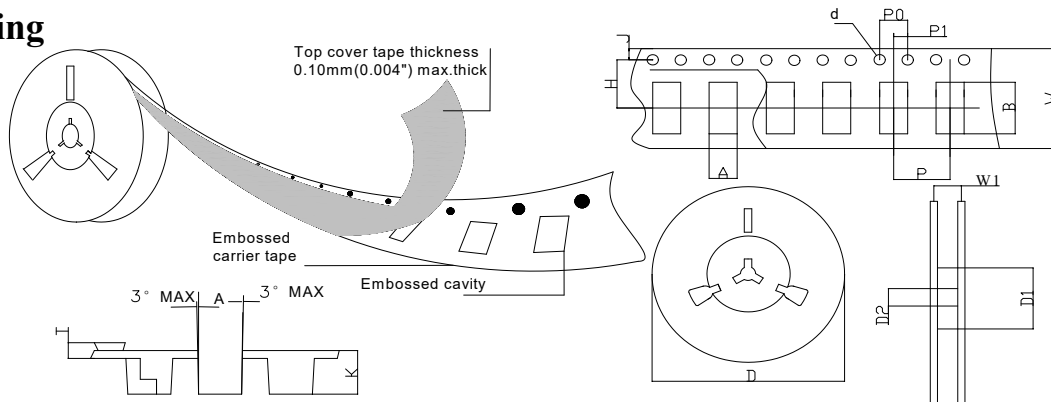

SPECIFICATIONS mm(inch)		PACKAGE	SPECIFICATIONS mm(inch)		PACKAGE
ITEM	SYM BOL	PS-277B	ITEM	SYM BOL	PS-277B
Carrier width	A	4.45(0.175)Max	Carrier depth	K	1.60(0.063)Typ
Carrier length	B	7.0(0.276)Max	Punch hole pitch	P	8.00(0.315)Typ
Sprocket hole	d	ø1.55(0.061)Typ	Sprocket hole pitch	P0	4.00(0.157)Typ
Reel outer diameter	D	330.0(13.0)Typ	Embossment center	P1	2.00(0.079)Typ
Reel inner diameter	D1	74.0(2.913)Min	Overall tape thickness	T	0.25(0.010)Typ
Feed hole diameter	D2	13.0(0.512)Typ	Tape width	W	16.0(0.630)Typ
Sprocket hole position	J	1.75(0.069)Typ	Reel width	W1	16.5(0.650)Min
Punch hole position	H	7.50(0.295)Typ			