

Uncoated Metallized Polyester Film Capacitor(Stacked version, uncoated)

■ Outline Drawing

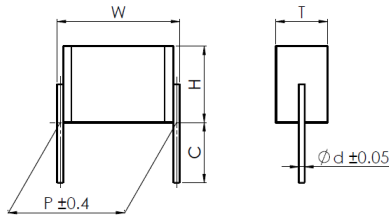

■ Features

- metallized polyester film, stacked construction, Uncoated
- High impulse and pulse strength

■ Typical Applications

- DC impulse and pulse circuits
- SMPS, converter, Electronic ballasts, compact fluorescent lamps

■ Specifications

| | | | | | |
|---|--|---|--|--------|--------|
| Reference Standard | GB/T 7332(IEC 60384-2) | | | | |
| Climatic Category | 55/125/56 | | | | |
| Rated Temperature | 85℃ | | | | |
| Operating Temperature Range | -55℃~125℃ (+85℃ to +125℃: decreasing factor 1.25% per °C for U_R) | | | | |
| Rated Voltage | 63V, 100V, 250V, 400V, 630V, 1 000V | | | | |
| Capacitance Range | 0.0010μF~10.0μF | | | | |
| Capacitance Tolerance | ±5%(J), ±10%(K), ±20%(M) | | | | |
| Voltage Proof | 1.40 U_R (2s) | | | | |
| Dissipation Factor | Frequency | $C_N \leq 0.1\mu F$ | $C_N > 0.1\mu F$ | | |
| | 1kHz | ≤1.0% | ≤1.0% | | |
| | 10kHz | ≤1.5% | - | | |
| | 100kHz | ≤3.0% | - | | |
| Insulation Resistance | $U_R \leq 100V$ | $\geq 3750M\Omega$, $C_N \leq 0.33\mu F$ $\geq 1250s$, $C_N > 0.33\mu F$ | $U_R < 100V$, charge voltage is 10V | | |
| | $U_R > 100V$ | $\geq 7500M\Omega$, $C_N \leq 0.33\mu F$ $\geq 2500s$, $C_N > 0.33\mu F$ | $U_R \geq 100V$, charge voltage is 100V (20℃, 1min) | | |
| Maximum Pulse Rise Time(dV/dt) If the working voltage(U) is lower than the rated voltage(U_R),the capacitor can be worked at a higher dV/dt. In this case, the maximum allowed dV/dt is obtain by multiplying the right value with U_R/U . | $U_R(V)$ | dV/dt (V/μs) | | | |
| | | P=5.0 | P=7.5 | P=10.0 | P=15.0 |
| | 63 | 120 | 120 | -- | -- |
| | 100 | 150 | 150 | 75 | 50 |
| | 250 | 250 | 200 | 150 | 100 |
| | 400 | 300 | 275 | 175 | 125 |
| | 630 | 400 | 320 | -- | 150 |
| 1 000 | 600 | 400 | -- | -- | |
| Storage Condition | Temperature: not exceeding 35 °C Humidity: not exceeding 75% RH Storage time: 6 months. If exceed 6 moths, pleas dry for 24 hours at 70±5 °C | | | | |

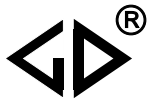

■ Part number system

The 18 digits part number is formed as follow:

| | | | | | | | | | | | | | | | | | |
|---|---|---|---|---|---|---|---|---|----|----|----|----|----|----|----|----|----|
| 1 | 2 | 3 | 4 | 5 | 6 | 7 | 8 | 9 | 10 | 11 | 12 | 13 | 14 | 15 | 16 | 17 | 18 |
| C | 2 | 5 | | | | | | | | | | | | | | | |

Digit 1 to 3 Series code

C25=CL25

Digit 4 to 5 DC rated voltage

1J=63V 2A=100V 2E=250V

2G=400V 2J=630V 3A=1000V

Digit 6 to 8 Rated capacitance value

For example : 103=10×10³pF=0.01uF

Digit 9 Capacitance tolerance

J=±5%,K=±10%, M=±20%

Digit 10 Lead pitch

2=5.0mm 3=7.5mm 4=10.0mm 6=15.0mm

Digit 11 Internal use

Digit 12 to 15 Lead form and packaging code

Digit 16 to 18 Internal use

Table 1 lead dimensions and packaging code

| Digit 12 | | Digit 13 | | Digit 14 | | Digit 15 | |
|----------|---|----------|-------------------------------------|----------|-------------|----------|---|
| code | explanation | code | explanation | code | explanation | code | explanation |
| A | ammo-pack | 2 | F=5.0mm | 0 | straight | 1 | each cap. among two consecutive holes P3=12.7mm,H=18.5mm (For pitch=5.0/7.5mm) |
| | | 3 | F=7.5mm | | | | |
| | | 4 | F=10.0mm | | | | |
| | | 6 | F=15.0mm | | | | |
| C | straight lead "C" in the figure above | code | explanation | 0 | | 0 | Length tolerance ±0.5mm Or standard length |
| | | 00 | standard lead length (18mm~22mm) | | | | |
| | | 45 | lead length 4.5mm | | | | |
| | | 35 | lead length 3.5mm | | | | |
| | | 32 | lead length 3.2mm | | | | |



■ Dimensions (mm)

| 63Vdc(40Vac) | | | | | | | 63Vdc(40Vac) | | | | | | | 63Vdc(40Vac) | | | | | | |
|------------------------|----------|----------|----------|-----|-----|-------------------|------------------------|----------|----------|----------|-----|-----|-------------------|------------------------|----------|----------|----------|-----|-----|-------------------|
| C _N (μF) | W max | H max | T max | P | d | Part number | C _N (μF) | W max | H max | T max | P | d | Part number | C _N (μF) | W max | H max | T max | P | d | Part number |
| 0.001 | 6.5 | 3.9 | 2.0 | 5.0 | 0.5 | C251J102-20****+3 | 0.039 | 6.5 | 4.7 | 2.7 | 5.0 | 0.5 | C251J393-20****+3 | 0.22 | 9.0 | 4.0 | 2.4 | 7.5 | 0.5 | C251J224-30****+3 |
| 0.001 | 6.5 | 4.0 | 2.2 | 5.0 | 0.5 | C251J122-20****+3 | 0.047 | 6.5 | 4.0 | 2.0 | 5.0 | 0.5 | C251J473-20****+3 | 0.27 | 9.0 | 4.6 | 2.5 | 7.5 | 0.5 | C251J274-30****+3 |
| 0.001 | 6.5 | 5.0 | 2.2 | 5.0 | 0.5 | C251J152-20****+3 | 0.056 | 6.5 | 4.1 | 2.2 | 5.0 | 0.5 | C251J563-20****+3 | 0.33 | 9.0 | 5.1 | 2.7 | 7.5 | 0.5 | C251J334-30****+3 |
| 0.001 | 6.5 | 4.9 | 2.5 | 5.0 | 0.5 | C251J182-20****+3 | 0.068 | 6.5 | 4.1 | 2.5 | 5.0 | 0.5 | C251J683-20****+3 | 0.39 | 9.0 | 5.9 | 2.7 | 7.5 | 0.5 | C251J394-30****+3 |
| 0.002 | 6.5 | 4.7 | 2.2 | 5.0 | 0.5 | C251J222-20****+3 | 0.082 | 6.5 | 4.4 | 2.7 | 5.0 | 0.5 | C251J823-20****+3 | 0.47 | 9.0 | 5.2 | 2.7 | 7.5 | 0.5 | C251J474-30****+3 |
| 0.002 | 6.5 | 4.7 | 2.5 | 5.0 | 0.5 | C251J272-20****+3 | 0.10 | 6.5 | 3.8 | 2.0 | 5.0 | 0.5 | C251J104-20****+3 | 0.56 | 9.0 | 6.2 | 2.7 | 7.5 | 0.5 | C251J564-30****+3 |
| 0.003 | 6.5 | 5.2 | 2.7 | 5.0 | 0.5 | C251J332-20****+3 | 0.12 | 6.5 | 3.9 | 2.2 | 5.0 | 0.5 | C251J124-20****+3 | 0.68 | 9.0 | 5.9 | 3.2 | 7.5 | 0.5 | C251J684-30****+3 |
| 0.003 | 6.5 | 3.8 | 2.0 | 5.0 | 0.5 | C251J392-20****+3 | 0.15 | 6.5 | 4.8 | 2.2 | 5.0 | 0.5 | C251J154-20****+3 | 0.82 | 9.0 | 5.9 | 3.7 | 7.5 | 0.5 | C251J824-30****+3 |
| 0.004 | 6.5 | 3.9 | 2.2 | 5.0 | 0.5 | C251J472-20****+3 | 0.18 | 6.5 | 4.9 | 2.4 | 5.0 | 0.5 | C251J184-20****+3 | 1.0 | 9.0 | 6.2 | 4.2 | 7.5 | 0.5 | C251J105-30****+3 |
| 0.005 | 6.5 | 4.6 | 2.2 | 5.0 | 0.5 | C251J562-20****+3 | 0.22 | 6.5 | 4.2 | 2.5 | 5.0 | 0.5 | C251J224-20****+3 | 1.2 | 9.0 | 6.4 | 4.8 | 7.5 | 0.5 | C251J125-30****+3 |
| 0.006 | 6.5 | 4.6 | 2.5 | 5.0 | 0.5 | C251J682-20****+3 | 0.27 | 6.5 | 4.6 | 2.7 | 5.0 | 0.5 | C251J274-20****+3 | 1.5 | 9.0 | 7.1 | 5.4 | 7.5 | 0.5 | C251J155-30****+3 |
| 0.008 | 6.5 | 5.0 | 2.7 | 5.0 | 0.5 | C251J822-20****+3 | 0.33 | 6.5 | 5.1 | 2.9 | 5.0 | 0.5 | C251J334-20****+3 | 1.8 | 9.0 | 7.6 | 5.7 | 7.5 | 0.5 | C251J185-30****+3 |
| 0.010 | 6.5 | 3.7 | 2.0 | 5.0 | 0.5 | C251J103-20****+3 | 0.39 | 6.5 | 5.2 | 3.2 | 5.0 | 0.5 | C251J394-20****+3 | 2.2 | 9.0 | 8.5 | 6.3 | 7.5 | 0.5 | C251J225-30****+3 |
| 0.012 | 6.5 | 4.1 | 2.0 | 5.0 | 0.5 | C251J123-20****+3 | 0.47 | 6.5 | 5.2 | 3.7 | 5.0 | 0.5 | C251J474-20****+3 | 2.7 | 9.0 | 9.6 | 6.7 | 7.5 | 0.5 | C251J275-30****+3 |
| 0.015 | 6.5 | 3.6 | 2.5 | 5.0 | 0.5 | C251J153-20****+3 | 0.56 | 6.5 | 7.4 | 3.2 | 5.0 | 0.5 | C251J564-20****+3 | 3.3 | 9.0 | 11.2 | 7.3 | 7.5 | 0.5 | C251J335-30****+3 |
| 0.018 | 6.5 | 4.3 | 2.5 | 5.0 | 0.5 | C251J183-20****+3 | 0.68 | 6.5 | 7.5 | 3.7 | 5.0 | 0.5 | C251J684-20****+3 | 3.9 | 9.0 | 11.3 | 8.3 | 7.5 | 0.5 | C251J395-30****+3 |
| 0.022 | 6.5 | 4.2 | 2.0 | 5.0 | 0.5 | C251J223-20****+3 | 0.82 | 6.5 | 7.7 | 4.2 | 5.0 | 0.5 | C251J824-20****+3 | 4.7 | 9.0 | 11.8 | 9.3 | 7.5 | 0.5 | C251J475-30****+3 |
| 0.027 | 6.5 | 4.4 | 2.2 | 5.0 | 0.5 | C251J273-20****+3 | 1.0 | 6.5 | 8.4 | 4.7 | 5.0 | 0.5 | C251J105-20****+3 | 5.6 | 9.0 | 13.0 | 10.2 | 7.5 | 0.5 | C251J565-30****+3 |
| 0.033 | 6.5 | 4.4 | 2.5 | 5.0 | 0.5 | C251J333-20****+3 | | | | | | | | 6.8 | 9.0 | 13.5 | 11.7 | 7.5 | 0.5 | C251J685-30****+3 |

| 100Vdc(63Vac) | | | | | | | 100Vdc(63Vac) | | | | | | | 100Vdc(63Vac) | | | | | | |
|------------------------|----------|----------|----------|-----|-----|-------------------|------------------------|----------|----------|----------|-----|-----|-------------------|------------------------|----------|----------|----------|------|-----|-------------------|
| C _N (μF) | W max | H max | T max | P | d | Part number | C _N (μF) | W max | H max | T max | P | d | Part number | C _N (μF) | W max | H max | T max | P | d | Part number |
| 0.0010 | 6.5 | 3.9 | 2.0 | 5.0 | 0.5 | C252A102-20****+3 | 0.18 | 6.5 | 4.9 | 2.4 | 5.0 | 0.5 | C252A184-20****+3 | 0.33 | 11.5 | 4.0 | 2.5 | 10.0 | 0.5 | C252A334-40****+3 |
| 0.0012 | 6.5 | 4.0 | 2.2 | 5.0 | 0.5 | C252A122-20****+3 | 0.22 | 6.5 | 4.7 | 2.9 | 5.0 | 0.5 | C252A224-20****+3 | 0.39 | 11.5 | 4.7 | 2.5 | 10.0 | 0.5 | C252A394-40****+3 |
| 0.0015 | 6.5 | 5.0 | 2.2 | 5.0 | 0.5 | C252A152-20****+3 | 0.27 | 6.5 | 5.0 | 3.2 | 5.0 | 0.5 | C252A274-20****+3 | 0.47 | 11.5 | 5.0 | 2.7 | 10.0 | 0.5 | C252A474-40****+3 |
| 0.0018 | 6.5 | 4.9 | 2.5 | 5.0 | 0.5 | C252A182-20****+3 | 0.33 | 6.5 | 5.1 | 3.7 | 5.0 | 0.5 | C252A334-20****+3 | 0.56 | 11.5 | 4.7 | 3.2 | 10.0 | 0.5 | C252A564-40****+3 |
| 0.0022 | 6.5 | 4.7 | 2.2 | 5.0 | 0.5 | C252A222-20****+3 | 0.39 | 6.5 | 7.2 | 3.2 | 5.0 | 0.5 | C252A394-20****+3 | 0.68 | 11.5 | 5.7 | 3.2 | 10.0 | 0.5 | C252A684-40****+3 |
| 0.0027 | 6.5 | 4.7 | 2.5 | 5.0 | 0.5 | C252A272-20****+3 | 0.47 | 6.5 | 7.2 | 3.7 | 5.0 | 0.5 | C252A474-20****+3 | 0.82 | 11.5 | 5.7 | 3.7 | 10.0 | 0.5 | C252A824-40****+3 |
| 0.0033 | 6.5 | 5.2 | 2.7 | 5.0 | 0.5 | C252A332-20****+3 | 0.56 | 6.5 | 7.3 | 4.2 | 5.0 | 0.5 | C252A564-20****+3 | 1.0 | 11.5 | 5.9 | 4.2 | 10.0 | 0.5 | C252A105-40****+3 |
| 0.0039 | 6.5 | 3.8 | 2.0 | 5.0 | 0.5 | C252A392-20****+3 | 0.68 | 6.5 | 7.9 | 4.7 | 5.0 | 0.5 | C252A684-20****+3 | 1.2 | 11.5 | 7.1 | 4.2 | 10.0 | 0.5 | C252A125-40****+3 |
| 0.0047 | 6.5 | 3.9 | 2.2 | 5.0 | 0.5 | C252A472-20****+3 | 0.82 | 6.5 | 8.2 | 5.3 | 5.0 | 0.5 | C252A824-20****+3 | 1.5 | 11.5 | 7.7 | 4.7 | 10.0 | 0.5 | C252A155-40****+3 |
| 0.0056 | 6.5 | 4.6 | 2.2 | 5.0 | 0.5 | C252A562-20****+3 | 1.0 | 6.5 | 8.5 | 5.7 | 5.0 | 0.5 | C252A105-20****+3 | 1.8 | 11.5 | 8.3 | 5.2 | 10.0 | 0.5 | C252A185-40****+3 |
| 0.0068 | 6.5 | 4.6 | 2.5 | 5.0 | 0.5 | C252A682-20****+3 | 0.10 | 9.0 | 4.1 | 2.4 | 7.5 | 0.5 | C252A104-30****+3 | 2.2 | 11.5 | 9.1 | 5.7 | 10.0 | 0.5 | C252A225-40****+3 |
| 0.0082 | 6.5 | 5.0 | 2.7 | 5.0 | 0.5 | C252A822-20****+3 | 0.12 | 9.0 | 4.2 | 2.7 | 7.5 | 0.5 | C252A124-30****+3 | 1.0 | 16.5 | 6.1 | 3.2 | 15.0 | 0.6 | C252A105-60****+3 |
| 0.010 | 6.5 | 3.7 | 2.0 | 5.0 | 0.5 | C252A103-20****+3 | 0.15 | 9.0 | 5.2 | 2.7 | 7.5 | 0.5 | C252A154-30****+3 | 1.2 | 16.5 | 5.9 | 3.7 | 15.0 | 0.6 | C252A125-60****+3 |
| 0.012 | 6.5 | 4.1 | 2.0 | 5.0 | 0.5 | C252A123-20****+3 | 0.18 | 9.0 | 3.8 | 2.2 | 7.5 | 0.5 | C252A184-30****+3 | 1.5 | 16.5 | 6.6 | 4.2 | 15.0 | 0.6 | C252A155-60****+3 |
| 0.015 | 6.5 | 3.6 | 2.5 | 5.0 | 0.5 | C252A153-20****+3 | 0.22 | 9.0 | 4.0 | 2.4 | 7.5 | 0.5 | C252A224-30****+3 | 1.8 | 16.5 | 7.5 | 4.4 | 15.0 | 0.6 | C252A185-60****+3 |
| 0.018 | 6.5 | 4.3 | 2.5 | 5.0 | 0.5 | C252A183-20****+3 | 0.27 | 9.0 | 4.2 | 2.7 | 7.5 | 0.5 | C252A274-30****+3 | 2.2 | 16.5 | 7.5 | 5.2 | 15.0 | 0.6 | C252A225-60****+3 |
| 0.022 | 6.5 | 4.2 | 2.0 | 5.0 | 0.5 | C252A223-20****+3 | 0.33 | 9.0 | 5.1 | 2.7 | 7.5 | 0.5 | C252A334-30****+3 | 2.7 | 16.5 | 8.5 | 5.5 | 15.0 | 0.6 | C252A275-60****+3 |
| 0.027 | 6.5 | 4.4 | 2.2 | 5.0 | 0.5 | C252A273-20****+3 | 0.39 | 9.0 | 5.9 | 2.7 | 7.5 | 0.5 | C252A394-30****+3 | 3.3 | 16.5 | 9.3 | 6.0 | 15.0 | 0.6 | C252A335-60****+3 |
| 0.033 | 6.5 | 4.4 | 2.5 | 5.0 | 0.5 | C252A333-20****+3 | 0.47 | 9.0 | 5.7 | 3.2 | 7.5 | 0.5 | C252A474-30****+3 | 3.9 | 16.5 | 10.5 | 6.2 | 15.0 | 0.6 | C252A395-60****+3 |
| 0.039 | 6.5 | 4.7 | 2.7 | 5.0 | 0.5 | C252A393-20****+3 | 0.56 | 9.0 | 5.6 | 3.7 | 7.5 | 0.5 | C252A564-30****+3 | 4.7 | 16.5 | 10.8 | 7.0 | 15.0 | 0.6 | C252A475-60****+3 |
| 0.047 | 6.5 | 4.0 | 2.0 | 5.0 | 0.5 | C252A473-20****+3 | 0.68 | 9.0 | 5.8 | 4.2 | 7.5 | 0.5 | C252A684-30****+3 | 5.6 | 16.5 | 11.9 | 7.6 | 15.0 | 0.6 | C252A565-60****+3 |
| 0.056 | 6.5 | 4.1 | 2.2 | 5.0 | 0.5 | C252A563-20****+3 | 0.82 | 9.0 | 7.0 | 4.2 | 7.5 | 0.5 | C252A824-30****+3 | 6.8 | 16.5 | 12.4 | 8.7 | 15.0 | 0.6 | C252A685-60****+3 |
| 0.068 | 6.5 | 4.1 | 2.5 | 5.0 | 0.5 | C252A683-20****+3 | 1.0 | 9.0 | 7.4 | 4.7 | 7.5 | 0.5 | C252A105-30****+3 | 8.2 | 16.5 | 13.1 | 9.7 | 15.0 | 0.6 | C252A825-60****+3 |
| 0.082 | 6.5 | 4.4 | 2.7 | 5.0 | 0.5 | C252A823-20****+3 | 1.2 | 9.0 | 7.4 | 5.5 | 7.5 | 0.5 | C252A125-30****+3 | 10.0 | 16.5 | 14.5 | 10.6 | 15.0 | 0.6 | C252A106-60****+3 |
| 0.10 | 6.5 | 3.8 | 2.0 | 5.0 | 0.5 | C252A104-20****+3 | 1.5 | 9.0 | 8.0 | 6.3 | 7.5 | 0.5 | C252A155-30****+3 | | | | | | | |
| 0.12 | 6.5 | 3.9 | 2.2 | 5.0 | 0.5 | C252A124-20****+3 | 1.8 | 9.0 | 9.7 | 6.2 | 7.5 | 0.5 | C252A185-30****+3 | | | | | | | |
| 0.15 | 6.5 | 4.8 | 2.2 | 5.0 | 0.5 | C252A154-20****+3 | 2.2 | 9.0 | 10.3 | 7.2 | 7.5 | 0.5 | C252A225-30****+3 | | | | | | | |

Note: 1. “-”=capacitance tolerance code, M=±20%,K=±10%,J=±5%
2. “****”=lead form and packaging code (refer to table 1).



■ Dimensions (mm)

| 630Vdc(400Vac) | | | | | | | 630Vdc(400Vac) | | | | | | | 630Vdc(400Vac) | | | | | | |
|------------------------|----------|----------|----------|-----|-----|--------------------|------------------------|----------|----------|----------|-----|-----|--------------------|------------------------|----------|----------|----------|------|-----|--------------------|
| C _N (μF) | W max | H max | T max | P | d | Part number | C _N (μF) | W max | H max | T max | P | d | Part number | C _N (μF) | W max | H max | T max | P | d | Part number |
| 0.0010 | 6.5 | 3.9 | 2.0 | 5.0 | 0.5 | C252J102-20****+++ | 0.0010 | 9.0 | 3.7 | 2.0 | 7.5 | 0.5 | C252J102-30****+++ | 0.10 | 16.5 | 9.2 | 5.0 | 15.0 | 0.6 | C252J104-60****+++ |
| 0.0012 | 6.5 | 4.0 | 2.2 | 5.0 | 0.5 | C252J122-20****+++ | 0.0012 | 9.0 | 3.7 | 2.0 | 7.5 | 0.5 | C252J122-30****+++ | 0.12 | 16.5 | 9.8 | 5.8 | 15.0 | 0.6 | C252J124-60****+++ |
| 0.0015 | 6.5 | 5.0 | 2.2 | 5.0 | 0.5 | C252J152-20****+++ | 0.0015 | 9.0 | 4.0 | 2.2 | 7.5 | 0.5 | C252J152-30****+++ | 0.15 | 16.5 | 11.2 | 6.2 | 15.0 | 0.6 | C252J154-60****+++ |
| 0.0018 | 6.5 | 4.9 | 2.5 | 5.0 | 0.5 | C252J182-20****+++ | 0.0018 | 9.0 | 4.7 | 2.2 | 7.5 | 0.5 | C252J182-30****+++ | 0.18 | 16.5 | 11.2 | 7.2 | 15.0 | 0.6 | C252J184-60****+++ |
| 0.0022 | 6.5 | 4.7 | 2.2 | 5.0 | 0.5 | C252J222-20****+++ | 0.0022 | 9.0 | 3.7 | 2.2 | 7.5 | 0.5 | C252J222-30****+++ | 0.22 | 16.5 | 12.6 | 7.7 | 15.0 | 0.6 | C252J224-60****+++ |
| 0.0027 | 6.5 | 4.7 | 2.5 | 5.0 | 0.5 | C252J272-20****+++ | 0.0027 | 9.0 | 4.0 | 2.4 | 7.5 | 0.5 | C252J272-30****+++ | 0.27 | 16.5 | 14.3 | 8.2 | 15.0 | 0.6 | C252J274-60****+++ |
| 0.0033 | 6.5 | 5.2 | 2.7 | 5.0 | 0.5 | C252J332-20****+++ | 0.0033 | 9.0 | 3.8 | 2.2 | 7.5 | 0.5 | C252J332-30****+++ | 0.33 | 16.5 | 14.4 | 9.9 | 15.0 | 0.6 | C252J334-60****+++ |
| 0.0039 | 6.5 | 5.5 | 2.9 | 5.0 | 0.5 | C252J392-20****+++ | 0.0039 | 9.0 | 3.9 | 2.2 | 7.5 | 0.5 | C252J392-30****+++ | 0.39 | 16.5 | 15.2 | 10.9 | 15.0 | 0.6 | C252J394-60****+++ |
| 0.0047 | 6.5 | 4.9 | 2.5 | 5.0 | 0.5 | C252J472-20****+++ | 0.0047 | 9.0 | 4.1 | 2.4 | 7.5 | 0.5 | C252J472-30****+++ | 0.47 | 16.5 | 17.5 | 11.3 | 15.0 | 0.6 | C252J474-60****+++ |
| 0.0056 | 6.5 | 5.2 | 2.7 | 5.0 | 0.5 | C252J562-20****+++ | 0.0056 | 9.0 | 4.6 | 2.5 | 7.5 | 0.5 | C252J562-30****+++ | | | | | | | |
| 0.0068 | 6.5 | 5.0 | 3.2 | 5.0 | 0.5 | C252J682-20****+++ | 0.0068 | 9.0 | 5.0 | 2.7 | 7.5 | 0.5 | C252J682-30****+++ | | | | | | | |
| 0.0082 | 6.5 | 5.4 | 3.5 | 5.0 | 0.5 | C252J822-20****+++ | 0.0082 | 9.0 | 6.1 | 2.7 | 7.5 | 0.5 | C252J822-30****+++ | | | | | | | |
| 0.010 | 6.5 | 5.7 | 3.9 | 5.0 | 0.5 | C252J103-20****+++ | 0.010 | 9.0 | 6.2 | 3.2 | 7.5 | 0.5 | C252J103-30****+++ | | | | | | | |
| 0.012 | 6.5 | 7.3 | 3.7 | 5.0 | 0.5 | C252J123-20****+++ | 0.012 | 9.0 | 5.8 | 3.7 | 7.5 | 0.5 | C252J123-30****+++ | | | | | | | |
| | | | | | | | 0.015 | 9.0 | 6.2 | 4.2 | 7.5 | 0.5 | C252J153-30****+++ | | | | | | | |
| | | | | | | | 0.018 | 9.0 | 7.4 | 4.2 | 7.5 | 0.5 | C252J183-30****+++ | | | | | | | |
| | | | | | | | 0.022 | 9.0 | 7.9 | 4.7 | 7.5 | 0.5 | C252J223-30****+++ | | | | | | | |
| | | | | | | | 0.027 | 9.0 | 7.8 | 5.7 | 7.5 | 0.5 | C252J273-30****+++ | | | | | | | |
| | | | | | | | 0.033 | 9.0 | 9.5 | 5.7 | 7.5 | 0.5 | C252J333-30****+++ | | | | | | | |
| | | | | | | | 0.039 | 9.0 | 10.2 | 6.3 | 7.5 | 0.5 | C252J393-30****+++ | | | | | | | |
| | | | | | | | 0.047 | 9.0 | 11.2 | 6.8 | 7.5 | 0.5 | C252J473-30****+++ | | | | | | | |

| 1 000Vdc(600Vac) | | | | | | | 1 000Vdc(600Vac) | | | | | | | 1 000Vdc(600Vac) | | | | | | |
|------------------------|----------|----------|----------|-----|-----|--------------------|------------------------|----------|----------|----------|-----|-----|--------------------|------------------------|----------|----------|----------|-----|-----|--------------------|
| C _N (μF) | W max | H max | T max | P | d | Part number | C _N (μF) | W max | H max | T max | P | d | Part number | C _N (μF) | W max | H max | T max | P | d | Part number |
| 0.0010 | 6.5 | 3.9 | 2.0 | 5.0 | 0.5 | C253A102-20****+++ | 0.0010 | 9.0 | 3.7 | 2.0 | 7.5 | 0.5 | C253A102-30****+++ | 0.012 | 9.0 | 7.3 | 4.7 | 7.5 | 0.5 | C253A123-30****+++ |
| 0.0012 | 6.5 | 4.0 | 2.2 | 5.0 | 0.5 | C253A122-20****+++ | 0.0012 | 9.0 | 3.7 | 2.0 | 7.5 | 0.5 | C253A122-30****+++ | 0.015 | 9.0 | 8.1 | 5.2 | 7.5 | 0.5 | C253A153-30****+++ |
| 0.0015 | 6.5 | 5.0 | 2.2 | 5.0 | 0.5 | C253A152-20****+++ | 0.0015 | 9.0 | 4.0 | 2.2 | 7.5 | 0.5 | C253A152-30****+++ | 0.018 | 9.0 | 9.7 | 5.2 | 7.5 | 0.5 | C253A183-30****+++ |
| 0.0018 | 6.5 | 4.9 | 2.5 | 5.0 | 0.5 | C253A182-20****+++ | 0.0018 | 9.0 | 4.7 | 2.2 | 7.5 | 0.5 | C253A182-30****+++ | 0.022 | 9.0 | 10.6 | 5.7 | 7.5 | 0.5 | C253A223-30****+++ |
| 0.0022 | 6.5 | 4.7 | 2.2 | 5.0 | 0.5 | C253A222-20****+++ | 0.0022 | 9.0 | 3.7 | 2.2 | 7.5 | 0.5 | C253A222-30****+++ | 0.027 | 9.0 | 11.8 | 6.3 | 7.5 | 0.5 | C253A273-30****+++ |
| 0.0027 | 6.5 | 4.7 | 2.5 | 5.0 | 0.5 | C253A272-20****+++ | 0.0027 | 9.0 | 4.6 | 2.2 | 7.5 | 0.5 | C253A272-30****+++ | 0.033 | 9.0 | 13.2 | 6.8 | 7.5 | 0.5 | C253A333-30****+++ |
| 0.0033 | 6.5 | 5.2 | 2.7 | 5.0 | 0.5 | C253A332-20****+++ | 0.0033 | 9.0 | 4.6 | 2.5 | 7.5 | 0.5 | C253A332-30****+++ | | | | | | | |
| 0.0039 | 6.5 | 5.5 | 2.9 | 5.0 | 0.5 | C253A392-20****+++ | 0.0039 | 9.0 | 4.9 | 2.7 | 7.5 | 0.5 | C253A392-30****+++ | | | | | | | |
| 0.0047 | 6.5 | 5.8 | 3.2 | 5.0 | 0.5 | C253A472-20****+++ | 0.0047 | 9.0 | 5.8 | 2.7 | 7.5 | 0.5 | C253A472-30****+++ | | | | | | | |
| 0.0056 | 6.5 | 5.8 | 3.7 | 5.0 | 0.5 | C253A562-20****+++ | 0.0056 | 9.0 | 5.5 | 3.2 | 7.5 | 0.5 | C253A562-30****+++ | | | | | | | |
| 0.0068 | 6.5 | 8.4 | 3.2 | 5.0 | 0.5 | C253A682-20****+++ | 0.0068 | 9.0 | 6.7 | 3.2 | 7.5 | 0.5 | C253A682-30****+++ | | | | | | | |
| 0.0082 | 6.5 | 8.4 | 3.7 | 5.0 | 0.5 | C253A822-20****+++ | 0.0082 | 9.0 | 6.7 | 3.7 | 7.5 | 0.5 | C253A822-30****+++ | | | | | | | |
| 0.010 | 6.5 | 8.8 | 4.2 | 5.0 | 0.5 | C253A103-20****+++ | 0.010 | 9.0 | 7.0 | 4.2 | 7.5 | 0.5 | C253A103-30****+++ | | | | | | | |

- Note: 1. “-”=capacitance tolerance code, M=±20%,K=±10%,J=±5%
 2. “****”=lead form and packaging code (refer to table 1).

■ MAX. VOLTAGE(Vr.m.s) VERSUS FREQUENCY

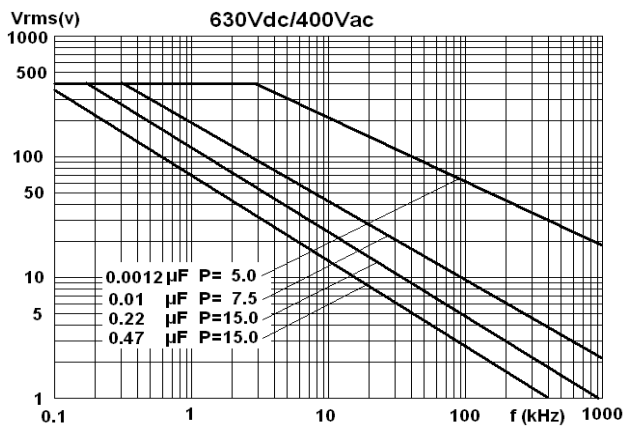
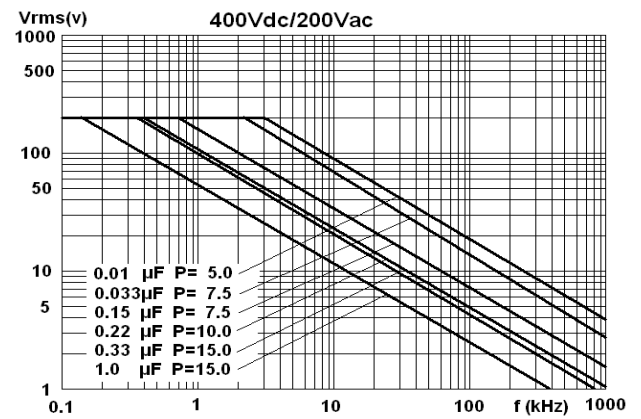
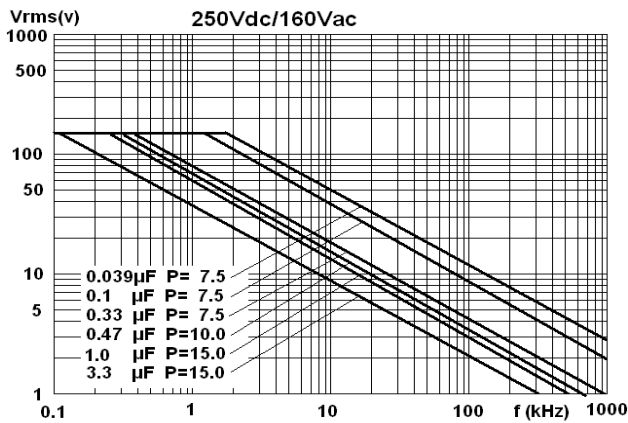
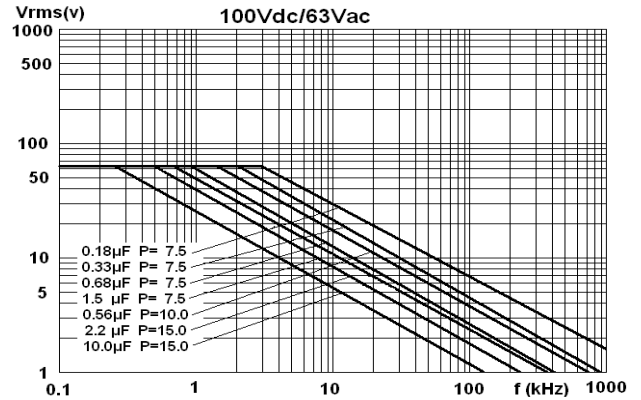
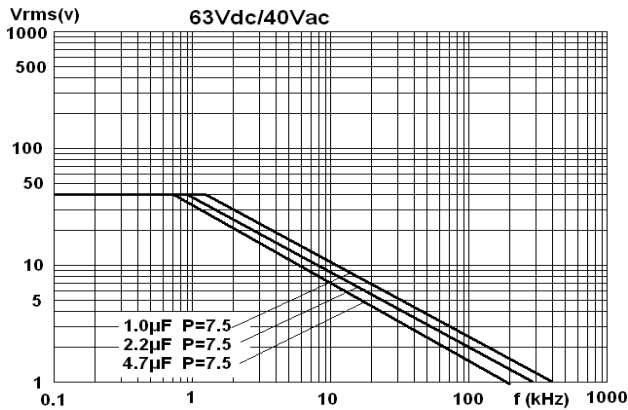

Note: sinusoidal wave-form、environment temperature $\leq 85^{\circ}\text{C}$, internal temperature rise $\Delta T=15^{\circ}\text{C}$, p (pitch) in mm.

■ Test Method And Performance

| No. | Item | Performance | Test method (GB/T 7332(IEC 60384-2)) |
|-----|-----------------------------|--|--|
| 1 | Solderability | Good quality of tinning | Solder temperature: 245°C±5°C Immersion time: 2.0s±0.5s |
| 2 | Initial measurement | Capacitance, Tanδ | |
| | Terminal strength | There shall be no visible damage | Tension U _{a1} : Pull: φ _d =0.5mm, 5N φ _d ≥0.6mm, 10N Bend U _b : The pull of bend: φ _d =0.5mm, 2.5N φ _d ≥0.6mm, 5N The terminals shall be bent 2 times in each direction. |
| | Resistance to solder heat | There shall be no visible damage, legible marking | Solder temperature: 260°C±5°C Immersion time: 10s±1s |
| | Final measurement | ΔC/C ≤ ±2%(relative to the initial value) Increase of tanδ: ≤0.003 (C≤1.0μF) ≤0.002 (C>1.0μF) | |
| 3 | Initial measurement | Capacitance, Tanδ | |
| | Rapid change of temperature | There shall be no evidence of deterioration. | θ _A =-55°C, θ _B =+125°C 5 cycles Duration: t=30min |
| | Vibration | There shall be no evidence of deterioration. | Amplitude 0.75mm or acceleration 98m/s ² (whichever is the smaller severity), f: 10Hz to 500Hz. Three directions, 2h for each direction, total 6h. |
| | Bump | There shall be no evidence of deterioration. | 4 000 times, Acceleration: 390m/s ² , Pulse duration, 6ms |
| | Final measurement | ΔC/C ≤ ±5%(relative to the initial value) Increase of tanδ: ≤0.003 (C≤1.0μF) ≤0.002 (C>1.0μF) IR: ≥ 50% of the rated value | |
| 4 | climate sequence | Initial measurement | Capacitance, Tanδ |
| | | Dry heat | +125°C, 16h |
| | | Damp heat, Cyclic | Test Db, Severity: b, the first cycle |
| | | Cold | -55°C, 2h |
| | | Low air pressure | There shall be no permanent breakdown, flashover or other harmful deformation when applying U _R at the last 1 minute. 15°C~ 35°C, 8.5kPa, 1h, |
| | | Damp heat, cyclic other | Test Db, Severity b, the other cycles, Applying U _R for 1 minute after the test finished. |
| | | Final measurement | There shall be no evidence of deterioration and the marking shall be legible. ΔC/C ≤ ±5%(relative to the initial value) Increase of tanδ: ≤0.005 (C≤1.0μF) ≤0.003 (C>1.0μF) IR: ≥50% of the rated value |



| No. | Item | Performance | Test method (GB 7332(IEC 60384-2)) |
|-----|----------------------------|--|--|
| 5 | Damp heat steady state | There shall be no evidence of deterioration and the marking shall be legible. $\Delta C/C \leq \pm 5\%$ (relative to the initial value) Increase of $\tan \delta \leq 0.005$ IR: $\geq 50\%$ of the rated value | Temperature: $40^\circ\text{C} \pm 2^\circ\text{C}$ Humidity: $93 \pm \frac{2}{3} \% \text{RH}$ Duration: 56 days |
| 6 | Endurance | There shall be no evidence of deterioration and the marking shall be legible. $\Delta C/C \leq \pm 5\%$ (relative to the initial value) Increase of $\tan \delta$: $C \leq 1.0 \mu\text{F}, \leq 0.003$; $C > 1.0 \mu\text{F}, \leq 0.002$ IR: $\geq 50\%$ of the rated value | $+85^\circ\text{C}, 1.25 \times U_R$ 1 000h or $+125^\circ\text{C}, 1.25 \times U_c$ ($U_c = 0.5 U_R$) 1 000h |
| 7 | Temperature characteristic | Measuring capacitance at test point b, d, f: Characteristic at lower category temperature -55°C : $-10\% \leq (C_b - C_d) / C_d \leq 0\%$ Characteristic at upper category temperature $+125^\circ\text{C}$: $0\% \leq (C_f - C_d) / C_d \leq +18\%$ I.R. (test at point f): $U_R \leq 100\text{V}$: $\geq 75 \text{ M}\Omega$ ($C \leq 0.33 \mu\text{F}$) $\geq 25\text{s}$ ($C > 0.33 \mu\text{F}$) $U_R > 100\text{V}$: $\geq 150 \text{ M}\Omega$ ($C \leq 0.33 \mu\text{F}$) $\geq 50\text{s}$ ($C > 0.33 \mu\text{F}$) | Static method: The Capacitors should be kept at the following temperature in turn: a(20 ± 2) $^\circ\text{C}$, b(-55 ± 3) $^\circ\text{C}$, d(20 ± 2) $^\circ\text{C}$, f(125 ± 2) $^\circ\text{C}$, g(20 ± 2) $^\circ\text{C}$ |
| 8 | Charging and discharging | $\Delta C/C \leq \pm 5\%$ (relative to the initial value) Increase of $\tan \delta$: ≤ 0.003 ($C \leq 1.0 \mu\text{F}$) ≤ 0.002 ($C > 1.0 \mu\text{F}$) IR: $\geq 50\%$ of the rated value | Ref. item 4.13 Times: 10 000 Duration of charging: 0.5s Duration of discharging: 0.5s Charging voltage: rated voltage Charging resistance: $220 / C_N (\Omega)$ or current intensity $\leq 1\text{A}$ (whichever is the less current intensity) Discharging resistance: $R = U_R / (10 \times C_N \times dV/dt)$ C_N : rated capacitance (μF) |

■ Quality ensuring test (before shipment):

| Inspection item (each batch) | Inspection level (GB 2828) | |
|------------------------------|----------------------------|-------|
| | IL | AQL |
| Appearance inspection | S-4 | 1.5% |
| Dimensions | | |
| Capacitance | II | 0.65% |
| Tangent of the loss angle | | |
| Dielectric strength | | |
| Insulation resistance | | |
| Solderability | S-3 | 2.5% |

■ Marking

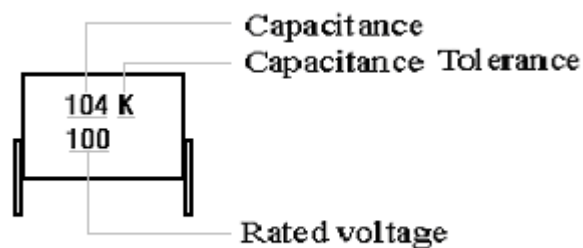

■ Taping specification

1. **Taping Dimensions:** Refer to table 2
2. **Outline Drawing:** Refer to Fig 1 ~ Fig 3

Table 2 Taping Dimensions

Unit: mm

| Specification | Code | Dimensions | | | | Note |
|--------------------------------------|------|------------|-------|--------|--------------|-----------------------|
| | | P=7.5 | | P=10.0 | Tolerance | |
| Code of Ammo Tapped | | A301 | A211 | A402 | | Digit 12 to 15 of P/N |
| Taping type | — | Fig 1 | Fig 2 | Fig3 | — | — |
| Lead dia. | d | 0.5 | | 0.5 | ±0.05 | — |
| Taping pitch | P3 | 12.7 | | 12.7 | ±1.0 | — |
| Feed hole pitch | P0 | 12.7 | | 12.7 | ±0.3 | 1mm(max)/20×P 0 |
| Center of wire | P1 | 2.6 | 3.85 | 7.7 | ±0.7 | — |
| Center of body | P2 | 6.35 | | 12.7 | ±1.3 | — |
| Pitch | P | 7.5 | | 10.0 | | |
| Component alignment | △S | 0 | | 0 | ±2.0 | — |
| Pitch of taping wire | F | / | 5.0 | / | +0.6 -0.1 | — |
| Height of component from tape center | H0 | / | 16.0 | / | ±0.5 | — |
| Height of crangle from tape center | H | 18.5 | 20.0 | 18.5 | ±0.5 | |
| Carrier tape width | W | 18.0 | | 18.0 | +1.0 -0.5 | — |
| Hold down tape width | W0 | 10min | | 10min | — | — |
| Hole position | W1 | 9.0 | | 9.0 | ±0.5 | — |
| Hold down tape sition | W2 | 3.0max | | | — | — |
| Feed hole dia. | D0 | 4.0 | | 4.0 | ±0.2 | — |
| Tape thickness | t | 0.7 | | 0.7 | ±0.2 | — |

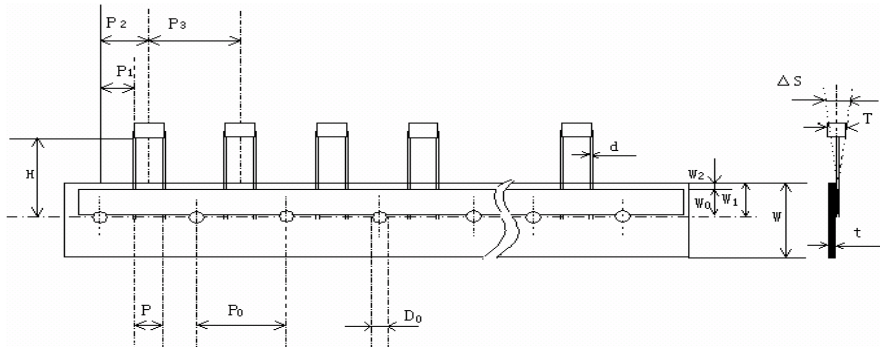

Fig 1

| | |
|--|---------|
| Specification | P=7.5mm |
| Code of Ammo | A301 |
| Feed hole pitch P0 (mm) | 12.7 |
| Pitch of taping wire F(mm) | / |
| Height of crangle from tape center H(mm) | 18.5 |

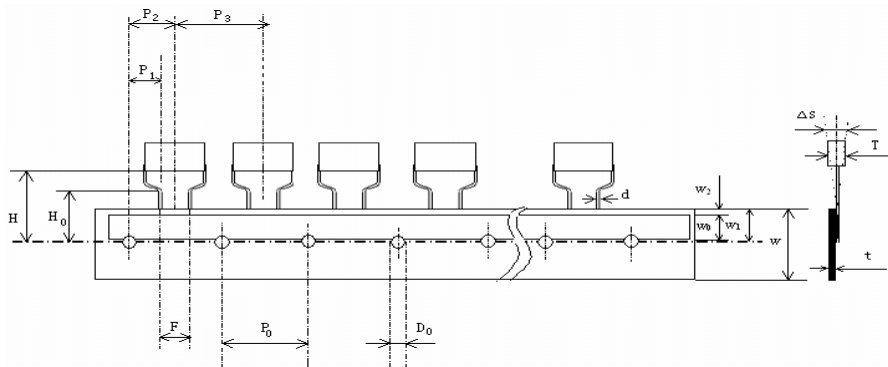

Fig 2

| | |
|--|---------|
| Specification | P=7.5mm |
| Code of Ammo | A211 |
| Feed hole pitch P0 (mm) | 12.7 |
| Pitch of taping wire F(mm) | 5.0 |
| Height of crangle from tape center H(mm) | 20 |

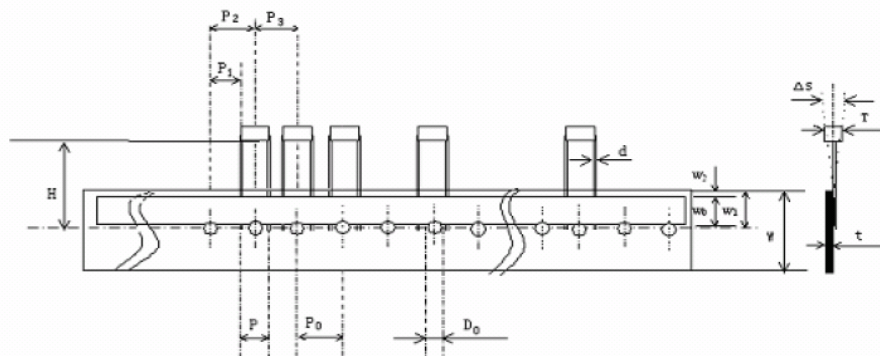
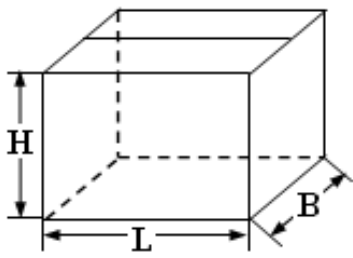

Fig3

| | |
|--|----------|
| Specification | P=10.0mm |
| Code of Ammo | A402 |
| Feed hole pitch P0 (mm) | 12.7 |
| Pitch of taping wire F(mm) | / |
| Height of crangle from tape center H(mm) | 18.5 |

■ Packing box sizes(mm)

1. Out packing box for bulk



L:375±5
B:375±5
H:265±5

2. Inner packing box for bulk

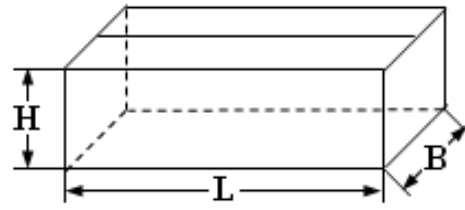

L:355±3
B:175±3
H:118±3

3. Box sizes for Ammo-pack

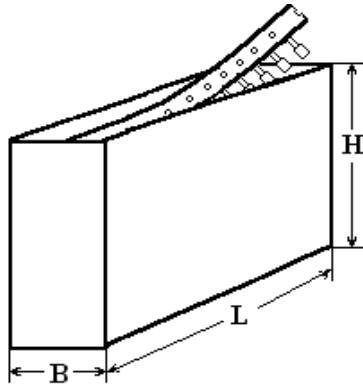

L:330±3
B:48±3
H:260±3