

---

## Two-Wire High Accuracy Differential Speed Sensor IC

---

### Features

- Two-wire current interface
- High sensitivity
- South and North pole pre-induction possible
- Large air gap
- Single chip solution
- Wide operating temperature range
- Output protection against electrical disturbances

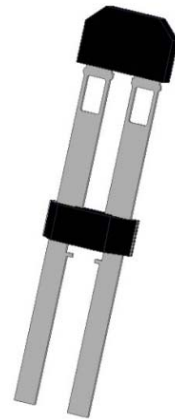

### Description

The differential Hall Effect sensor SC9641TS is designed to provide information about rotational speed to modern vehicle dynamics control systems and ABS. The output has been designed as a two-wire current interface. Excellent accuracy and sensitivity are specified for harsh automotive requirements with a wide temperature range, high ESD and EMC robustness.

The regulated current output is configured for two-wire applications and the 2.0mm spacing between the dual Hall elements is optimized for fine pitch ring-magnet-based configurations.

The device is packaged in a 2-pin plastic SIP. It is lead (Pb) free, with 100% matte tin-plated lead frame.

## Device Information

Part Number	Packing	Mounting	Ambient, T <sub>A</sub>	Marking
SC9641TS	1500 pieces/bag	2-pin SIP	-40°C to 150°C	9641

## Terminal Configuration and Functions

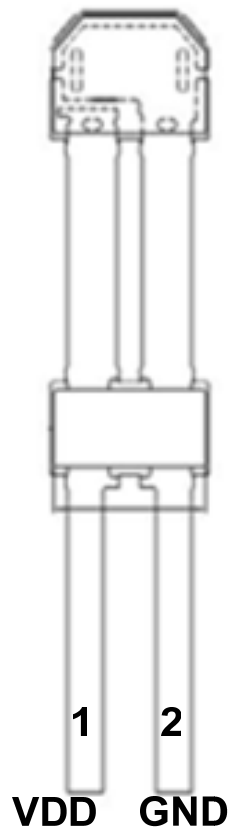

Terminal		Type	Description
Name	Number		
VDD	1	PWR	4.5V to 24 V power supply
GND	2	Ground	Ground

## Functional Block Diagram

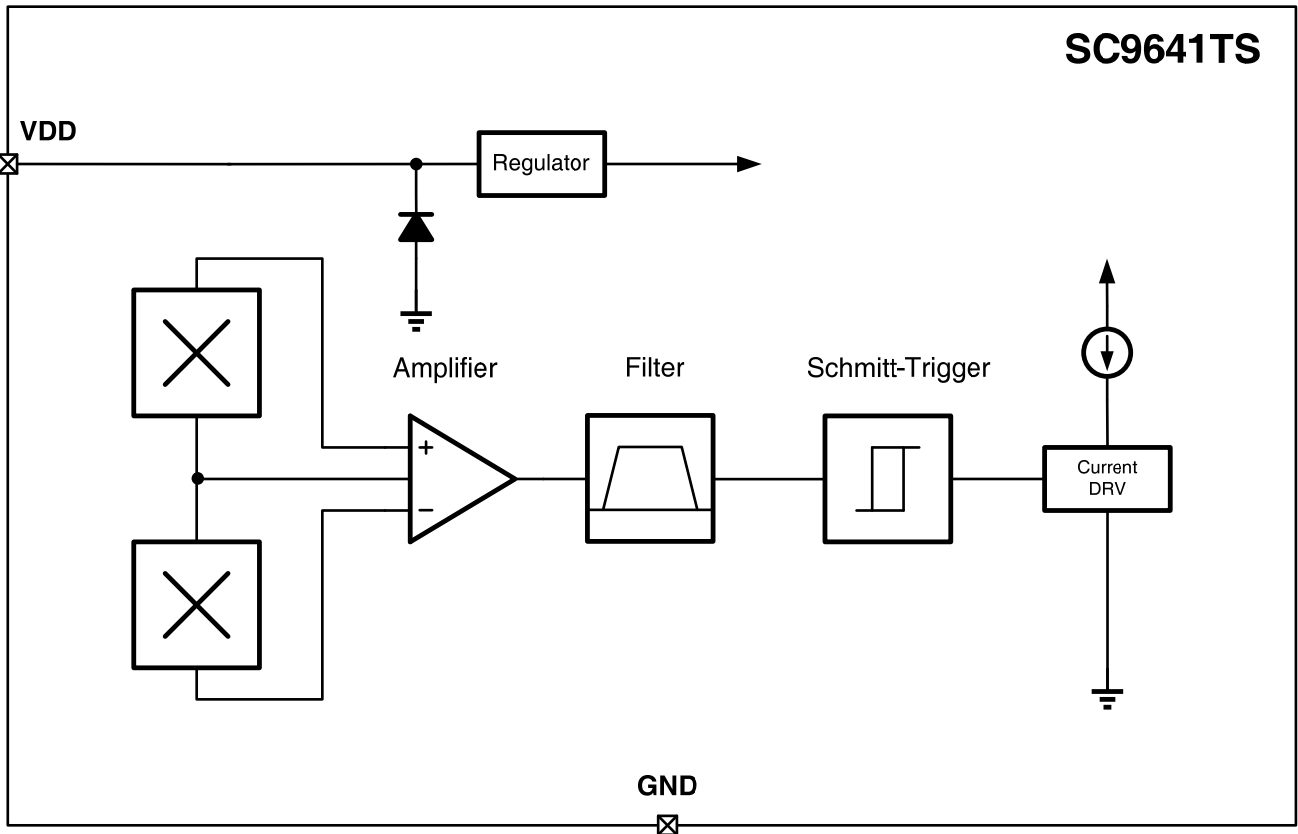

## Functional Description

The SC9641TS is an optimized Hall Effect sensing integrated circuit that provides a user-friendly solution for ring-magnet sensing in two-wire applications. This small package can be easily assembled used in conjunction with a wide variety of target shapes and sizes.

The integrated circuit incorporates a dual-element Hall Effect sensor and signal processing that switches to differential magnetic signals created by ring magnet poles. The regulated current output is configured for two-wire applications and the sensor is ideally suited for obtaining speed and duty cycle information in ABS (antilock braking systems). The 2.0 mm spacing between the dual Hall elements is optimized for fine pitch ring-magnet-based configurations. The package is lead (Pb) free, with 100% matte tin lead frame plating.

## Absolute Maximum Ratings

over operating free-air temperature range

Parameter	Symbol	Min.	Max.	Units
Power supply voltage	V <sub>DD</sub>	-0.5	30	V
Output terminal voltage	V <sub>OUT</sub>	-0.5	30	V
Output terminal current sink	I <sub>SINK</sub>	0	20	mA
Operating ambient temperature	T <sub>A</sub>	-40	150	°C
Maximum junction temperature	T <sub>J</sub>	-55	165	°C
Storage Temperature	T <sub>STG</sub>	-65	175	°C

*Note: Stresses above those listed here may cause permanent damage to the device. Exposure to absolute maximum rating conditions for extended periods may affect device reliability.*

## ESD Protection

*Human Body Model (HBM) tests according to: standard EIA/JESD22-A114-B HBM*

Parameter	Symbol	Limit Values		Units
		Min.	Max.	
ESD-Protection	V <sub>ESD</sub>	-8	8	KV

## Operating Characteristics

over operating free-air temperature range ( $V_{DD}=12V$ , unless otherwise noted)

Symbol	Parameter	Test Conditions	Min.	Typ.	Max.	Units
$V_{DD}$	Operating voltage	$T_J < T_{J(max)}$	4.5	--	24	V
$I_{DD(Low)}$	Operating supply current	$V_{DD}=4.5V$ to 24 V	5.9	7.0	8.4	mA
$I_{DD(High)}$	Operating supply current	$V_{DD}=4.5V$ to 24 V	12.0	14.0	16.0	mA
$R_{CUR}$	Supply current ratio	$I_{DD(High)} / I_{DD(Low)}$	1.9	--	--	--
$t_{po}^1$	Power-on time	$V_{DD} > 4.5V$	--	3.8	9	mS
$t_{settle}^2$	Settling time	$V_{DD} > 4.5V$ , $f=1kHz$	0	--	50	mS
$t_{response}^3$	Response time	$V_{DD} > 4.5V$ , $f=1kHz$	3.8	--	59	mS
$f_{cu}$	Upper corner frequency	-3dB, single pole	20	--	--	kHz
$f_{cl}$	Lower corner frequency	-3dB, single pole	--	--	5	Hz
Magnetic Characteristics						
$B_0$	Pre-induction		-500	--	500	mT
$B_{OP}$	Operated point	$f=1kHz$ , $B_{diff}=5mT$	--	--	0	mT
$B_{RP}$	Released point	$f=1kHz$ , $B_{diff}=5mT$	0	--	--	mT
$B_{HYS}$	Hysteresis		0.3	0.6	1.2	mT
$\Delta B_M$	Center of switching points		-2.0	0	+2.0	mT

<sup>1</sup>Time required to initialize device.

<sup>2</sup>Time required for the output switch points to be within specification.

<sup>3</sup>Equal to  $t_{po} + t_{settle}$ .

## Recommended Application

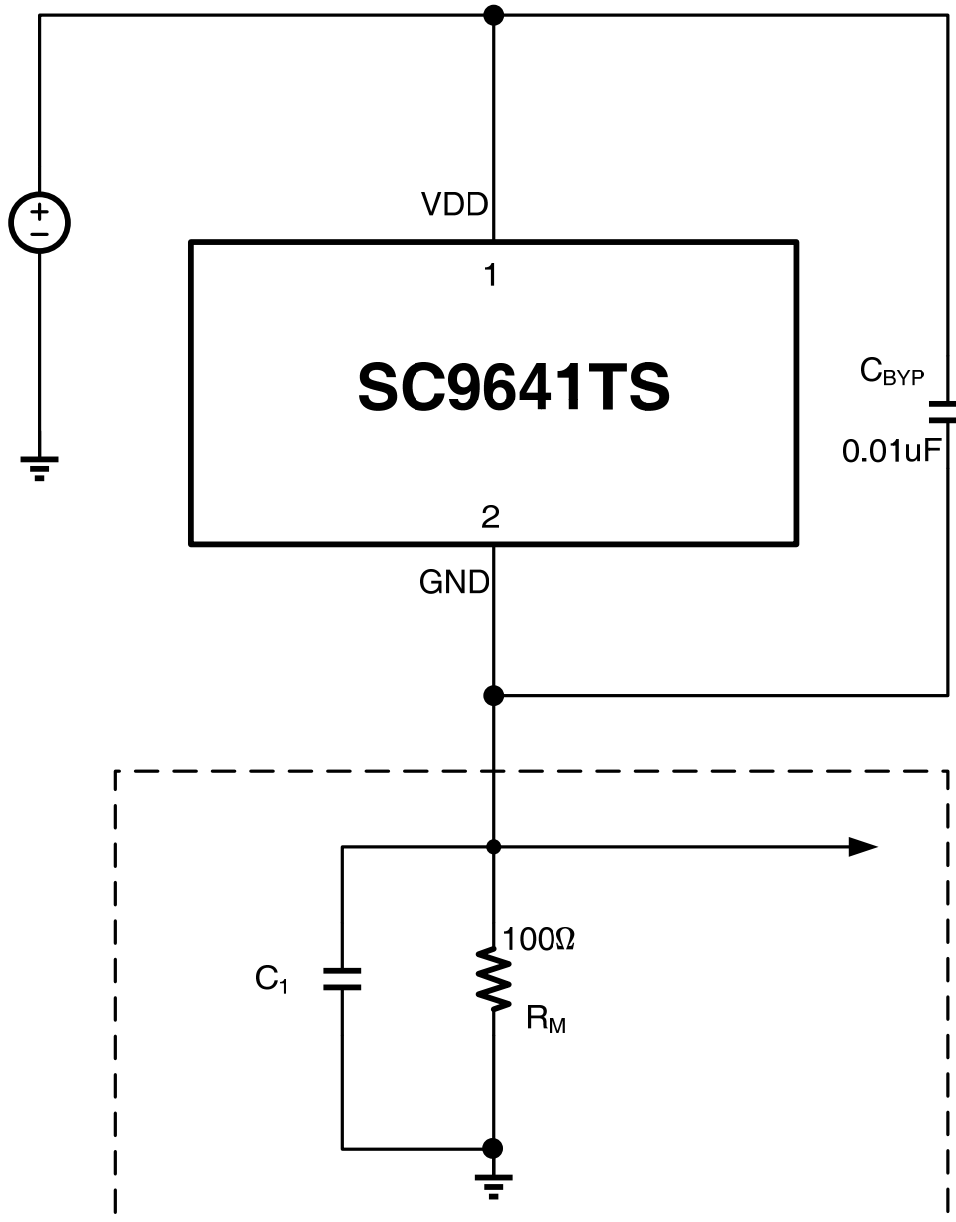

## Gear Tooth Sensing

In the case of ferromagnetic toothed wheel application, the IC can be biased by the South or North pole of a permanent magnet which should cover both Hall probes

The maximum air gap depends on

- the magnetic field strength (magnet used; pre-induction), and
- the toothed wheel that is used (dimensions, material, etc.)

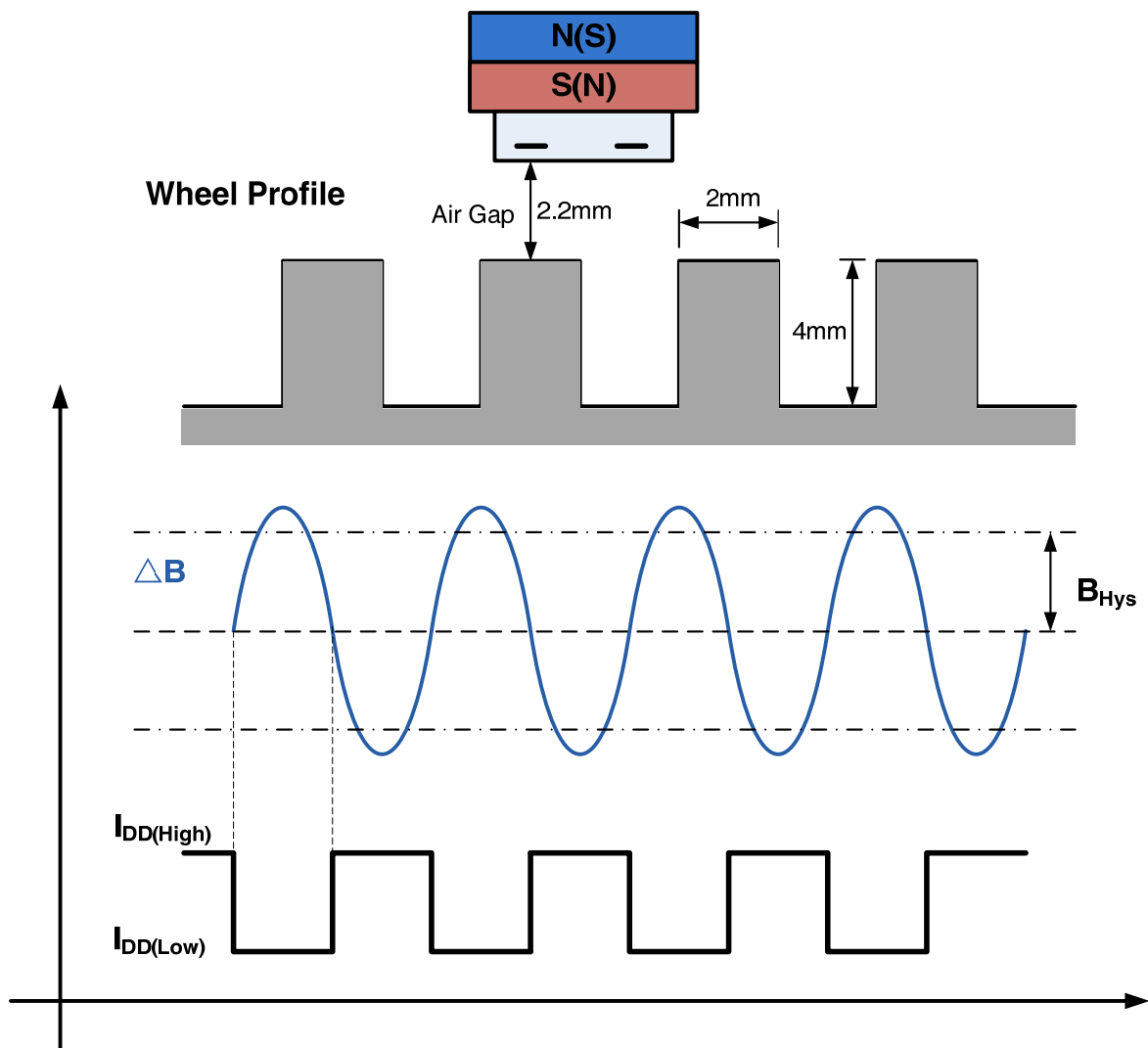

### Package Designator

