

OPAx376-Q1 Low-Noise, Low Quiescent Current, Precision Operational Amplifier *e-trim* Series

1 Features

- Qualified for Automotive Applications
- AEC-Q100 Qualified With the Following Results:
 - Device Temperature Grade 1: -40°C to $+125^{\circ}\text{C}$ Ambient Operating Temperature Range
 - Device HBM ESD Classification Level 3A
 - Device CDM ESD Classification Level C6
- Low Noise: $7.5\text{ nV}/\sqrt{\text{Hz}}$ at 1 kHz
- 0.1-Hz to 10-Hz Noise: $0.8\text{ }\mu\text{V}_{\text{PP}}$
- Quiescent Current: $760\text{ }\mu\text{A}$ (typical)
- Low Offset Voltage: $5\text{ }\mu\text{V}$ (typical)
- Gain Bandwidth Product: 5.5 MHz
- Rail-to-Rail Input and Output
- Single-Supply Operation
- Supply Voltage: 2.2 V to 5.5 V
- Space-Saving Packages:
 - SC70, SOT-23, VSSOP, TSSOP

2 Applications

- Active Cruise Control
- Park Assist
- Tire Pressure Monitoring
- Infotainment
- Active Filtering
- Sensor Signal Conditioning

3 Description

The OPA376-Q1 family represent a new generation of low-noise operational amplifiers with *e-trim*TM, offering outstanding dc precision and ac performance. Rail-to-rail output, low offset ($25\text{ }\mu\text{V}$ maximum), low noise ($7.5\text{ nV}/\sqrt{\text{Hz}}$), quiescent current of $950\text{ }\mu\text{A}$ (maximum), and a 5.5-MHz bandwidth make this part very attractive for a variety of precision and portable applications. In addition, this device has a reasonably wide supply range with excellent PSRR, making it attractive for applications that run directly from batteries without regulation.

The OPA376-Q1 (single version) is available in MicroSIZE SC70-5, SOT23-5, and SOIC-8 packages. The OPA2376-Q1 (dual) is offered in the SOIC-8 and VSSOP-8 package. The OPA4376-Q1 (quad) is offered in a TSSOP-14 package. All versions are specified for operation from -40°C to $+125^{\circ}\text{C}$.

Device Information⁽¹⁾

| PART NUMBER | PACKAGE | BODY SIZE (NOM) |
|-------------|------------|-------------------|
| OPA376-Q1 | SC70 (5) | 2.00 mm x 1.25 mm |
| | SOT-23 (5) | 2.90 mm x 1.60 mm |
| | SOIC (8) | 4.90 mm x 3.91 mm |
| OPA2376-Q1 | SOIC (8) | 4.90 mm x 3.91 mm |
| | VSSOP (8) | 3.00 mm x 3.00 mm |
| OPA4376-Q1 | TSSOP (14) | 5.00 mm x 4.40 mm |

(1) For all available packages, see the orderable addendum at the end of the datasheet.

Input Voltage Noise Spectral Density

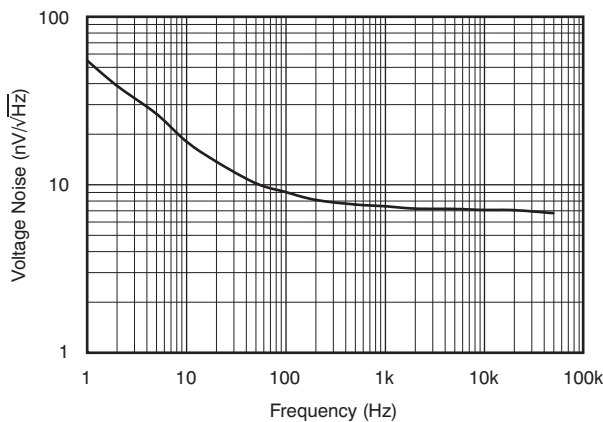

Offset Voltage Production Distribution

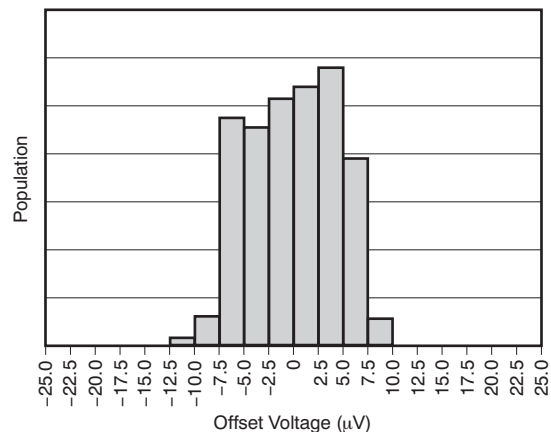

Table of Contents

| | | | | | |
|----------|--|-----------|-----------|---|-----------|
| 1 | Features | 1 | 7.4 | Device Functional Modes..... | 16 |
| 2 | Updated Applications examples | 1 | 8 | Application and Implementation | 17 |
| 3 | Description | 1 | 8.1 | Application Information..... | 17 |
| 4 | Revision History | 2 | 8.2 | Typical Application | 20 |
| 5 | Pin Configuration and Functions | 3 | 9 | Power Supply Recommendations | 21 |
| 6 | Specifications | 6 | 10 | Layout | 22 |
| 6.1 | Absolute Maximum Ratings | 6 | 10.1 | Layout Guidelines | 22 |
| 6.2 | ESD Ratings..... | 6 | 10.2 | Layout Example | 23 |
| 6.3 | Recommended Operating Conditions..... | 6 | 11 | Device and Documentation Support | 24 |
| 6.4 | Thermal Information: OPA376-Q1 | 7 | 11.1 | Device Support..... | 24 |
| 6.5 | Thermal Information: OPA2376-Q1 | 7 | 11.2 | Documentation Support | 24 |
| 6.6 | Thermal Information: OPA4376-Q1 | 7 | 11.3 | Related Links | 25 |
| 6.7 | Electrical Characteristics..... | 8 | 11.4 | Community Resource..... | 25 |
| 6.8 | Typical Characteristics..... | 10 | 11.5 | Trademarks | 25 |
| 7 | Detailed Description | 14 | 11.6 | Electrostatic Discharge Caution..... | 25 |
| 7.1 | Overview | 14 | 11.7 | Glossary | 25 |
| 7.2 | Functional Block Diagram | 14 | 12 | Mechanical, Packaging, and Orderable Information | 26 |
| 7.3 | Feature Description..... | 14 | | | |

4 Revision History

NOTE: Page numbers for previous revisions may differ from page numbers in the current version.

| Changes from Revision A (January 2016) to Revision B | Page |
|--|-------------|
| • Updated <i>Applications examples</i> | 1 |
| • Updated the <i>Pin Functions Table</i> for OPA4376-Q1 | 5 |
| • Updated <i>HBM ESD Rating</i> | 6 |
| • Changed units on <i>Channel Separation</i> | 8 |
| • Deleted the temperature range parameters from the <i>Electrical Characteristics</i> table..... | 9 |
| • Removed section regarding <i>WCSP photosensitivity</i> | 23 |

| Changes from Original (April 2011) to Revision A | Page |
|--|-------------|
| • Added <i>Pin Functions</i> table, <i>ESD Ratings</i> table, <i>Recommended Operating Conditions</i> table, <i>Thermal Information</i> tables, <i>Feature Description</i> section, <i>Device Functional Modes</i> , <i>Application and Implementation</i> section, <i>Power Supply Recommendations</i> section, <i>Layout</i> section, <i>Device and Documentation Support</i> section, and <i>Mechanical, Packaging, and Orderable Information</i> section | 1 |
| • Released the OPA2376-Q1 device as <i>Production Data</i> | 1 |
| • Added the <i>Input Offset Voltage and Input Offset Voltage Drift</i> section to the <i>Feature Description</i> | 14 |

5 Pin Configuration and Functions

**OPA376-Q1: DBV Package
5-Pin SOT-23
Top View**

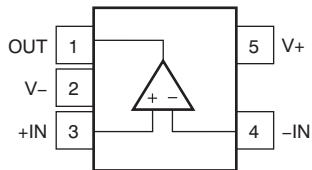

**OPA376-Q1: DCK Package
5-Pin SC70
Top View**

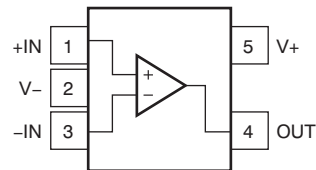

**OPA376-Q1: D Package
8-Pin SOIC
Top View**

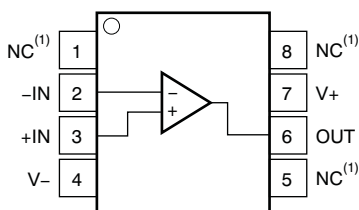

Pin Functions: OPA376-Q1

| NAME | PIN NO. | | | I/O | DESCRIPTION |
|-------------------|---------|------|------|-----|--|
| | SOT-23 | SC70 | SOIC | | |
| +IN | 3 | 1 | 3 | I | Noninverting input ⁺ |
| -IN | 4 | 3 | 2 | I | Inverting input ⁻ |
| NC ⁽¹⁾ | — | — | 1 | — | No connection |
| | | | 5 | | |
| | | | 8 | | |
| OUT | 1 | 4 | 6 | O | Output |
| V+ | 5 | 5 | 7 | — | Positive (highest) power supply ⁺ |
| V- | 2 | 2 | 4 | — | Negative (lowest) power supply ⁻ |

(1) NC denotes no internal connection.

**OPA2376-Q1: D and DGK Packages
8-Pin SOIC and VSSOP
Top View**

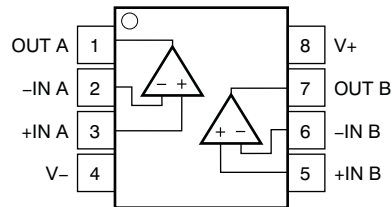

Pin Functions: OPA2376-Q1

| PIN | | I/O | DESCRIPTION |
|-------|-----|-----|--|
| NAME | NO. | | |
| +IN A | 3 | I | Noninverting input, channel A ⁺ |
| -IN A | 2 | I | Inverting input, channel A ⁻ |
| +IN B | 5 | I | Noninverting input, channel B ⁺ |
| -IN B | 6 | I | Inverting input, channel B ⁻ |
| OUT A | 1 | O | Output, channel A |
| OUT B | 7 | O | Output, channel B |
| V- | 4 | — | Negative (lowest) power supply |
| V+ | 8 | — | Positive (highest) power supply |

**OPA4376-Q1: PW Package
14-Pin TSSOP
Top View**

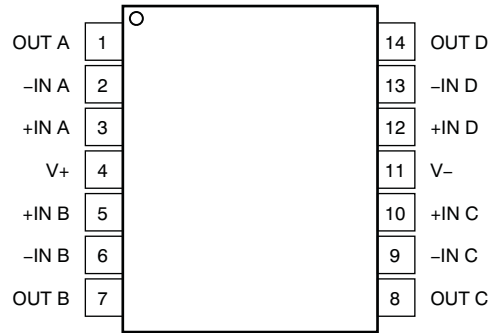

Pin Functions: OPA4376-Q1

| PIN | | I/O | DESCRIPTION |
|-------|-----|-----|--|
| NAME | NO. | | |
| +IN A | 3 | I | Noninverting input, channel A ⁺ |
| -IN A | 2 | I | Inverting input, channel A ⁻ |
| +IN B | 5 | I | Noninverting input, channel B ⁺ |
| -IN B | 6 | I | Inverting input, channel B ⁻ |
| +IN C | 10 | I | Noninverting input, channel C ⁺ |
| -IN C | 9 | I | Inverting input, channel C ⁻ |
| +IN D | 12 | I | Noninverting input, channel D ⁺ |
| -IN D | 13 | I | Inverting input, channel D ⁻ |
| OUT A | 1 | O | Output, channel A |
| OUT B | 7 | O | Output, channel B |
| OUT C | 8 | O | Output, channel C |
| OUT D | 14 | O | Output, channel D |
| V+ | 4 | — | Positive (highest) power supply |
| V- | 11 | — | Negative (lowest) power supply |

6 Specifications

6.1 Absolute Maximum Ratings

over operating free-air temperature range (unless otherwise noted)⁽¹⁾

| | | MIN | MAX | UNIT |
|---------------------|---|------------|------------|------|
| $V_S = (V+) - (V-)$ | Supply voltage | | 7 | V |
| | Signal input pin voltage ⁽²⁾ | (V-) – 0.5 | (V+) + 0.5 | V |
| | Signal input pin current ⁽²⁾ | –10 | 10 | mA |
| | Output short-circuit current ⁽³⁾ | Continuous | | |
| T_A | Operating temperature | –40 | 125 | °C |
| T_J | Junction temperature | | 150 | °C |
| T_{stg} | Storage temperature | –65 | 150 | °C |

- (1) Stresses beyond those listed under *Absolute Maximum Ratings* may cause permanent damage to the device. These are stress ratings only, which do not imply functional operation of the device at these or any other conditions beyond those indicated under *Recommended Operating Conditions*. Exposure to absolute-maximum-rated conditions for extended periods may affect device reliability.
- (2) Input terminals are diode-clamped to the power-supply rails. Input signals that can swing more than 0.5 V beyond the supply rails must be current limited to 10 mA or less.
- (3) Short-circuit to ground, one amplifier per package.

6.2 ESD Ratings

| | | VALUE | UNIT |
|-------------|-------------------------|---|-------|
| $V_{(ESD)}$ | Electrostatic discharge | Human-body model (HBM), per AEC Q100-002 ⁽¹⁾ | ±4000 |
| | | Charged-device model (CDM), per AEC Q100-011 | ±1000 |

- (1) AEC Q100-002 indicates that HBM stressing shall be in accordance with the ANSI/ESDA/JEDEC JS-001 specification.

6.3 Recommended Operating Conditions

over operating free-air temperature range (unless otherwise noted)

| | | MIN | MAX | UNIT |
|---------------------|-----------------------|------------|-------------|------|
| $V_S = (V+) - (V-)$ | Supply voltage | 2.2 (±1.1) | 5.5 (±2.75) | V |
| T_A | Operating temperature | –40 | 150 | °C |

6.4 Thermal Information: OPA376-Q1

| THERMAL METRIC ⁽¹⁾ | | OPA376-Q1 | | | UNIT |
|-------------------------------|--|------------|--------------|----------|------|
| | | DCK (SC70) | DBV (SOT-23) | D (SOIC) | |
| | | 5 PINS | 5 PINS | 8 PINS | |
| R _{θJA} | Junction-to-ambient thermal resistance | 267 | 273.8 | 100.1 | °C/W |
| R _{θJC(top)} | Junction-to-case (top) thermal resistance | 80.9 | 126.8 | 42.4 | °C/W |
| R _{θJB} | Junction-to-board thermal resistance | 54.8 | 85.9 | 41 | °C/W |
| ψ _{JT} | Junction-to-top characterization parameter | 1.2 | 10.9 | 4.8 | °C/W |
| ψ _{JB} | Junction-to-board characterization parameter | 54.1 | 84.9 | 40.3 | °C/W |
| R _{θJC(bot)} | Junction-to-case (bottom) thermal resistance | n/a | n/a | n/a | °C/W |

(1) For more information about traditional and new thermal metrics, see the *Semiconductor and IC Package Thermal Metrics* application report, [SPRA953](#).

6.5 Thermal Information: OPA2376-Q1

| THERMAL METRIC ⁽¹⁾ | | OPA2376-Q1 | | UNIT |
|-------------------------------|--|------------|-------------|------|
| | | D (SOIC) | DGK (VSSOP) | |
| | | 8 PINS | 8 PINS | |
| R _{θJA} | Junction-to-ambient thermal resistance | 111.1 | 171.2 | °C/W |
| R _{θJC(top)} | Junction-to-case (top) thermal resistance | 54.7 | 63.9 | °C/W |
| R _{θJB} | Junction-to-board thermal resistance | 51.7 | 92.8 | °C/W |
| ψ _{JT} | Junction-to-top characterization parameter | 10.5 | 9.2 | °C/W |
| ψ _{JB} | Junction-to-board characterization parameter | 51.2 | 91.2 | °C/W |
| R _{θJC(bot)} | Junction-to-case (bottom) thermal resistance | n/a | n/a | °C/W |

(1) For more information about traditional and new thermal metrics, see the *Semiconductor and IC Package Thermal Metrics* application report, [SPRA953](#).

6.6 Thermal Information: OPA4376-Q1

| THERMAL METRIC ⁽¹⁾ | | OPA4376-Q1 | UNIT |
|-------------------------------|--|------------|------|
| | | PW (TSSOP) | |
| | | 14 PINS | |
| R _{θJA} | Junction-to-ambient thermal resistance | 107.8 | °C/W |
| R _{θJC(top)} | Junction-to-case (top) thermal resistance | 29.6 | °C/W |
| R _{θJB} | Junction-to-board thermal resistance | 52.6 | °C/W |
| ψ _{JT} | Junction-to-top characterization parameter | 1.5 | °C/W |
| ψ _{JB} | Junction-to-board characterization parameter | 51.6 | °C/W |
| R _{θJC(bot)} | Junction-to-case (bottom) thermal resistance | n/a | °C/W |

(1) For more information about traditional and new thermal metrics, see the *Semiconductor and IC Package Thermal Metrics* application report, [SPRA953](#).

6.7 Electrical Characteristics

At $T_A = 25^\circ\text{C}$, $R_L = 10\text{ k}\Omega$ connected to $V_S / 2$, $V_{CM} = V_S / 2$, and $V_{OUT} = V_S / 2$, unless otherwise noted.

| PARAMETER | | TEST CONDITIONS | | MIN | TYP | MAX | UNIT |
|---------------------------|--|---|---|--------------|---|--------------|------------------------------|
| OFFSET VOLTAGE | | | | | | | |
| V_{OS} | Input offset voltage | | | | 5 | 25 | μV |
| dV_{OS}/dT | Input offset voltage versus temperature | $T_A = -40^\circ\text{C}$ to $+85^\circ\text{C}$ | | | 0.26 | 1 | $\mu\text{V}/^\circ\text{C}$ |
| | | $T_A = -40^\circ\text{C}$ to $+125^\circ\text{C}$ | | | 0.32 | 2 | $\mu\text{V}/^\circ\text{C}$ |
| PSRR | Input offset voltage versus power supply | $V_S = 2.2\text{ V}$ to 5.5 V , $V_{CM} < (V+) - 1.3\text{ V}$ | $T_A = 25^\circ\text{C}$ | | 5 | 20 | $\mu\text{V}/\text{V}$ |
| | | | $T_A = -40^\circ\text{C}$ to $+125^\circ\text{C}$ | | 5 | | $\mu\text{V}/\text{V}$ |
| | Channel separation, dc (dual, quad) | | | | 0.5 | | $\mu\text{V}/\text{V}$ |
| INPUT BIAS CURRENT | | | | | | | |
| I_B | Input bias current | $T_A = 25^\circ\text{C}$ | | | 0.2 | 10 | pA |
| | | $T_A = -40^\circ\text{C}$ to $+125^\circ\text{C}$ | | | See Typical Characteristics | | pA |
| I_{OS} | Input offset current | | | | 0.2 | 10 | pA |
| NOISE | | | | | | | |
| | Input voltage noise | $f = 0.1\text{ Hz}$ to 10 Hz | | | 0.8 | | μV_{PP} |
| e_n | Input voltage noise density | $f = 1\text{ kHz}$ | | | 7.5 | | $\text{nV}/\sqrt{\text{Hz}}$ |
| i_n | Input current noise | $f = 1\text{ kHz}$ | | | 2 | | $\text{fA}/\sqrt{\text{Hz}}$ |
| INPUT VOLTAGE | | | | | | | |
| V_{CM} | Common-mode voltage | | | $(V-) - 0.1$ | | $(V+) + 0.1$ | V |
| CMRR | Common-mode rejection ratio | $(V-) < V_{CM} < (V+) - 1.3\text{ V}$ | | 76 | 90 | | dB |
| INPUT CAPACITANCE | | | | | | | |
| | Differential | | | | 6.5 | | pF |
| | Common-mode | | | | 13 | | pF |
| OPEN-LOOP GAIN | | | | | | | |
| A_{OL} | Open-loop voltage gain | $50\text{ mV} < V_O < (V+) - 50\text{ mV}$, $R_L = 10\text{ k}\Omega$ | | 120 | 134 | | dB |
| | | $100\text{ mV} < V_O < (V+) - 100\text{ mV}$, $R_L = 2\text{ k}\Omega$ | | 120 | 126 | | dB |
| FREQUENCY RESPONSE | | | | | | | |
| GBW | Gain-bandwidth product | $C_L = 100\text{ pF}$, $V_S = 5.5\text{ V}$ | | | 5.5 | | MHz |
| SR | Slew rate | $G = 1$, $C_L = 100\text{ pF}$, $V_S = 5.5\text{ V}$ | | | 2 | | $\text{V}/\mu\text{s}$ |
| t_S | Settling time | 0.1%, 2-V Step, $G = 1$, $C_L = 100\text{ pF}$, $V_S = 5.5\text{ V}$ | | | 1.6 | | μs |
| | | 0.01%, 2-V Step, $G = 1$, $C_L = 100\text{ pF}$, $V_S = 5.5\text{ V}$ | | | 2 | | μs |
| | Overload recovery time | $V_{IN} \times \text{Gain} > V_S$ | | | 0.33 | | μs |
| THD+N | THD + noise | $V_O = 1\text{ V}_{RMS}$, $G = 1$, $f = 1\text{ kHz}$, $R_L = 10\text{ k}\Omega$ | | | 0.00027% | | |
| OUTPUT | | | | | | | |
| | Voltage output swing from rail | $R_L = 10\text{ k}\Omega$ | $T_A = 25^\circ\text{C}$ | | 10 | 20 | mV |
| | | | $T_A = -40^\circ\text{C}$ to $+125^\circ\text{C}$ | | | 40 | mV |
| | | $R_L = 2\text{ k}\Omega$ | $T_A = 25^\circ\text{C}$ | | 40 | 50 | mV |
| | | | $T_A = -40^\circ\text{C}$ to $+125^\circ\text{C}$ | | | 80 | mV |
| I_{SC} | Short-circuit current | | | | 30 / -50 | | mA |
| C_{LOAD} | Capacitive load drive | | | | See Typical Characteristics | | |
| R_O | Open-loop output impedance | | | | 150 | | Ω |

Electrical Characteristics (continued)

At $T_A = 25^\circ\text{C}$, $R_L = 10\text{ k}\Omega$ connected to $V_S / 2$, $V_{CM} = V_S / 2$, and $V_{OUT} = V_S / 2$, unless otherwise noted.

| PARAMETER | | TEST CONDITIONS | | MIN | TYP | MAX | UNIT |
|---------------------|---------------------------------|---|---|----------|-----|-----|---------------|
| POWER SUPPLY | | | | | | | |
| V_S | Specified voltage | | | 2.2 | | 5.5 | V |
| | Operating voltage | | | 2 to 5.5 | | | V |
| I_Q | Quiescent current per amplifier | $I_O = 0$, $V_S = 5.5\text{ V}$, $V_{CM} < (V+) - 1.3\text{ V}$ | $T_A = 25^\circ\text{C}$ | | 760 | 950 | μA |
| | | | $T_A = -40^\circ\text{C}$ to $+125^\circ\text{C}$ | | | 1 | mA |

6.8 Typical Characteristics

At $T_A = 25^\circ\text{C}$, $V_S = 5\text{ V}$, $R_L = 10\text{ k}\Omega$ connected to $V_S / 2$, $V_{CM} = V_S / 2$, and $V_{OUT} = V_S / 2$, unless otherwise noted.

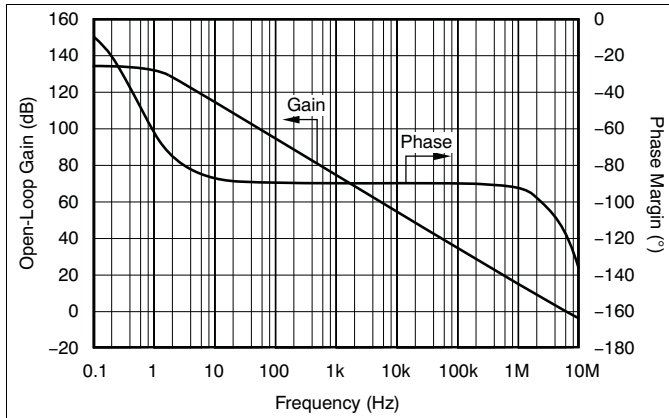

Figure 1. Open-Loop Gain and Phase vs Frequency

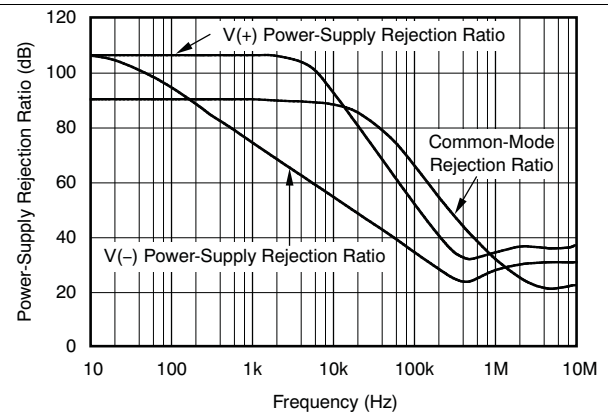

Figure 2. Power-Supply and Common-Mode Rejection Ratio vs Frequency

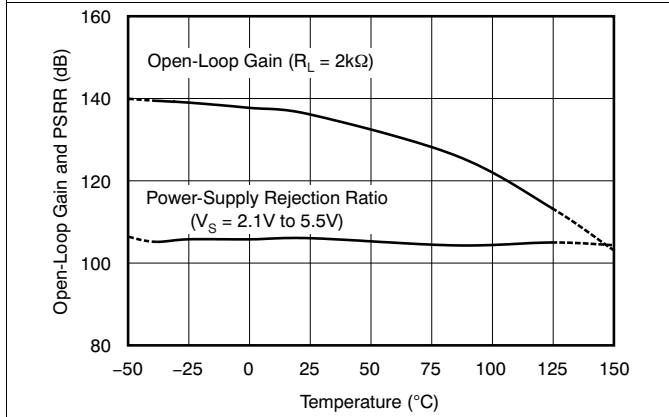

Figure 3. Open-Loop Gain and Power-Supply Rejection Ratio vs Temperature

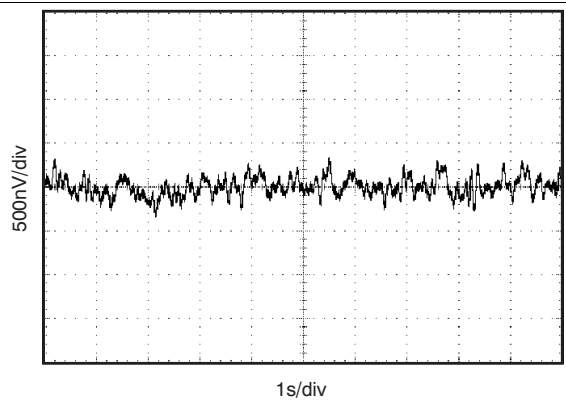

Figure 4. 0.1-Hz to 10-Hz Input Voltage Noise

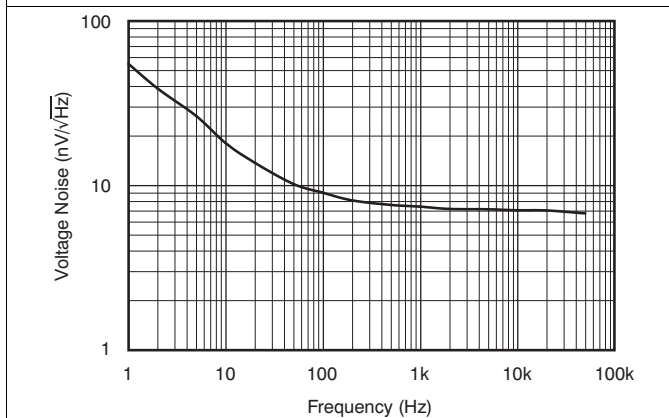

Figure 5. Input Voltage Noise Spectral Density

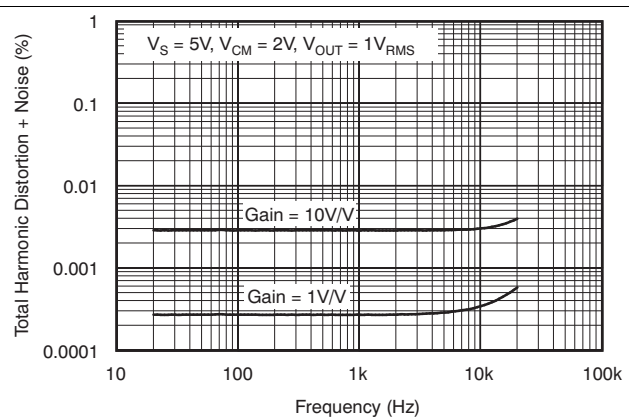

Figure 6. Total Harmonic Distortion + Noise vs Frequency

Typical Characteristics (continued)

At $T_A = 25^\circ\text{C}$, $V_S = 5\text{ V}$, $R_L = 10\text{ k}\Omega$ connected to $V_S / 2$, $V_{CM} = V_S / 2$, and $V_{OUT} = V_S / 2$, unless otherwise noted.

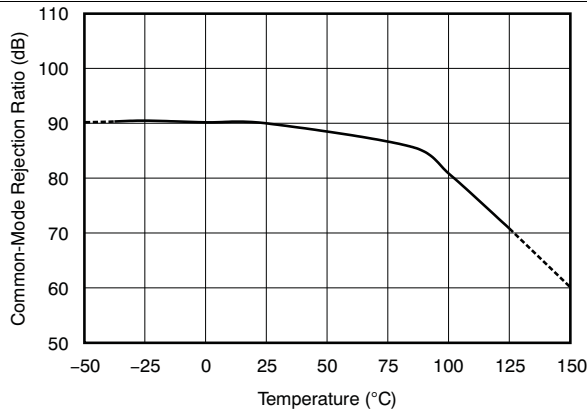

Figure 7. Common-Mode Rejection Ratio vs Temperature

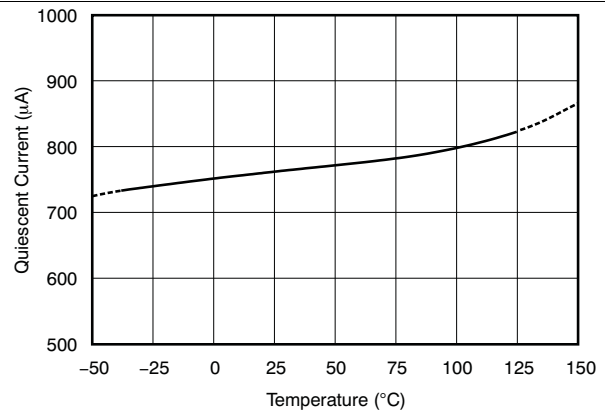

Figure 8. Quiescent Current vs Temperature

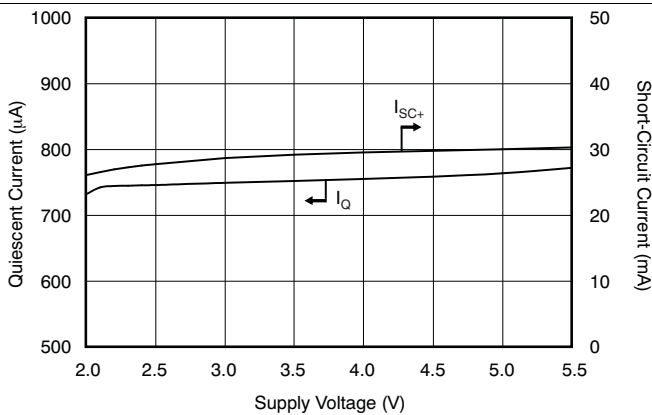

Figure 9. Quiescent and Short-Circuit Current vs Supply Voltage

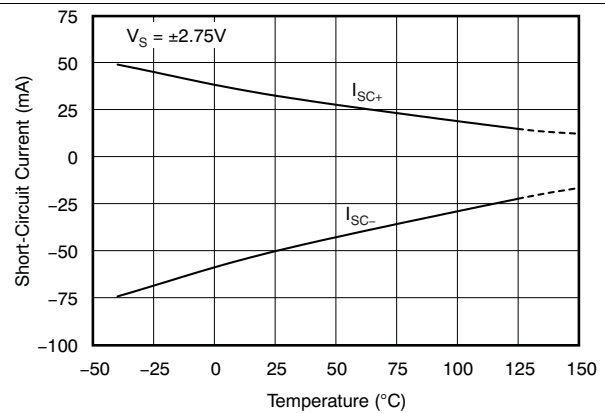

Figure 10. Short-Circuit Current vs Temperature

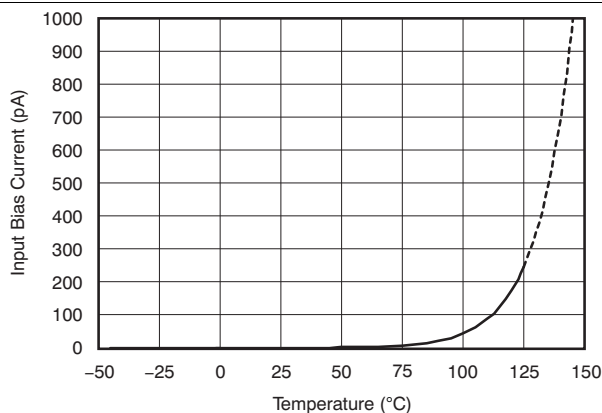

Figure 11. Input Bias Current vs Temperature

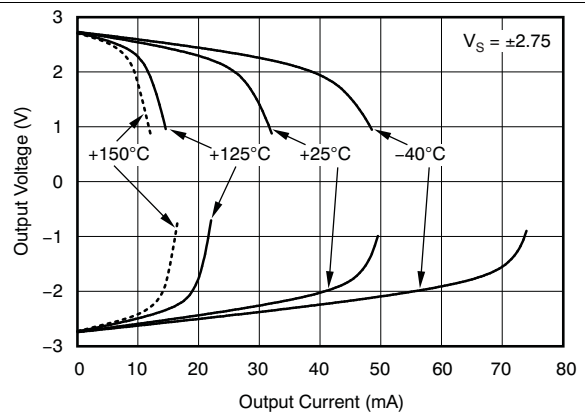

Figure 12. Output Voltage vs Output Current

Typical Characteristics (continued)

At $T_A = 25^\circ\text{C}$, $V_S = 5\text{ V}$, $R_L = 10\text{ k}\Omega$ connected to $V_S / 2$, $V_{CM} = V_S / 2$, and $V_{OUT} = V_S / 2$, unless otherwise noted.

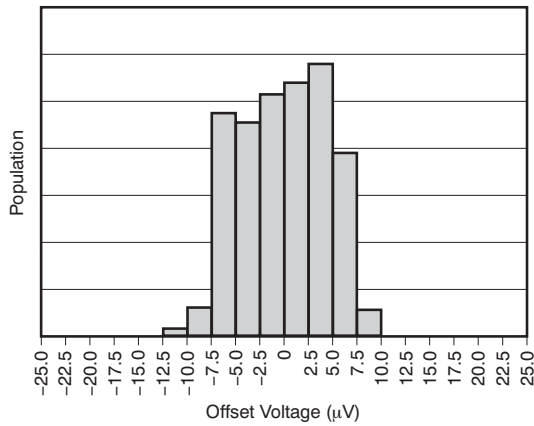

Figure 13. Offset Voltage Production Distribution

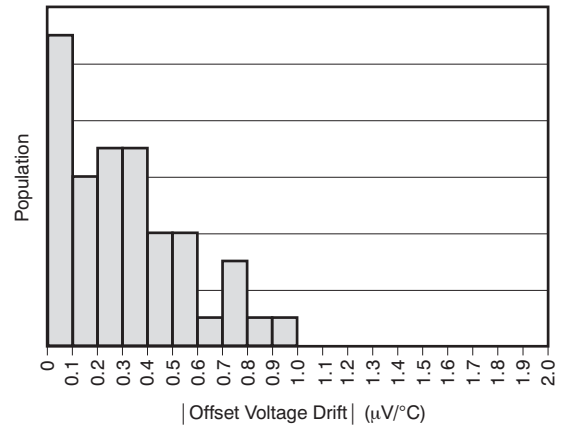

Figure 14. Offset Voltage Drift Production Distribution (-40°C to +125°C)

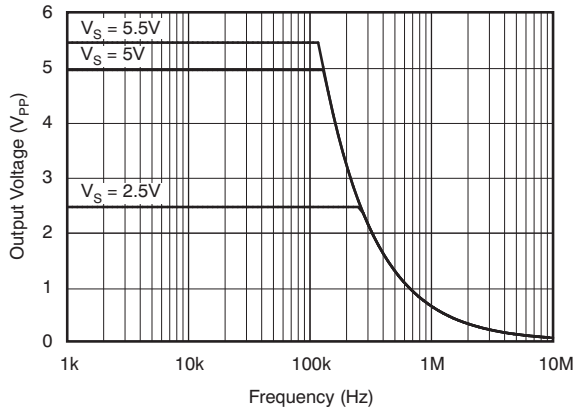

Figure 15. Maximum Output Voltage vs Frequency

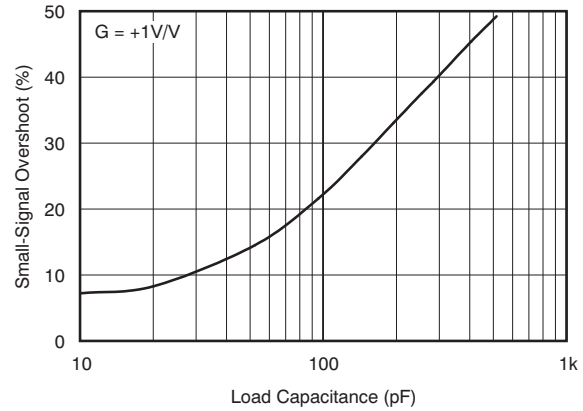

Figure 16. Small-Signal Overshoot vs Load Capacitance

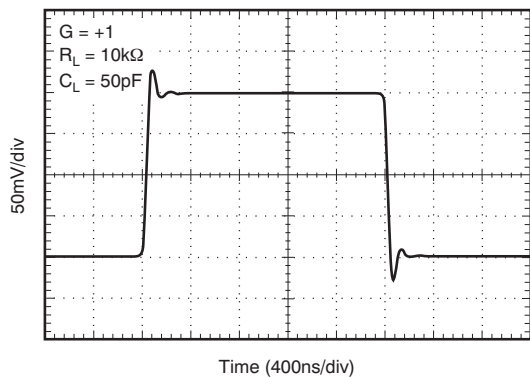

Figure 17. Small-Signal Pulse Response

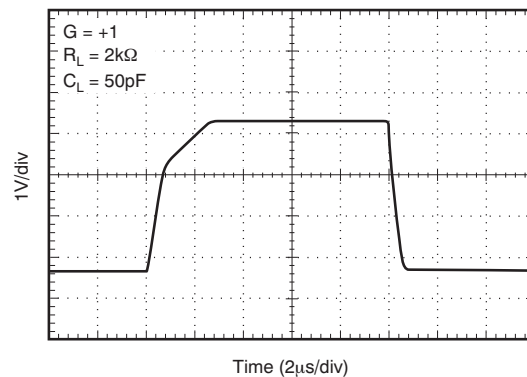

Figure 18. Large-Signal Pulse Response

Typical Characteristics (continued)

At $T_A = 25^\circ\text{C}$, $V_S = 5\text{ V}$, $R_L = 10\text{ k}\Omega$ connected to $V_S / 2$, $V_{CM} = V_S / 2$, and $V_{OUT} = V_S / 2$, unless otherwise noted.

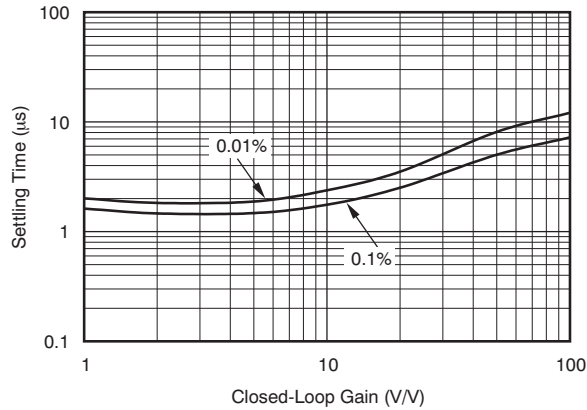

Figure 19. Settling Time vs Closed-Loop Gain

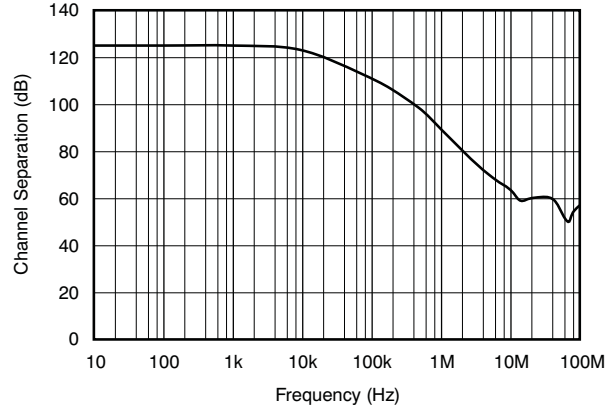

Figure 20. Channel Separation vs Frequency

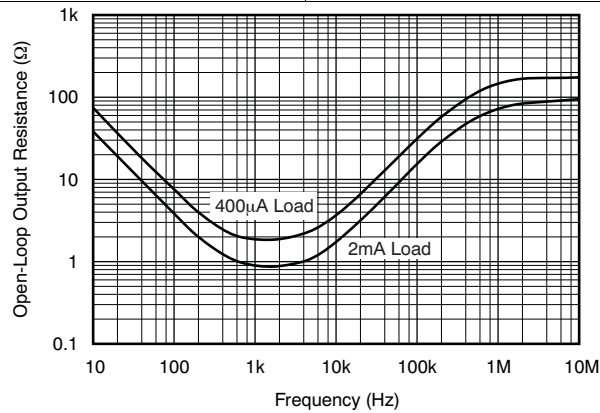

Figure 21. Open-Loop Output Resistance vs Frequency

7 Detailed Description

7.1 Overview

The OPA376-Q1 family belongs to a new generation of low-noise operational amplifiers with *e-trim*, giving customers outstanding dc precision and ac performance. Low noise, rail-to-rail input and output, and low offset, drawing a low quiescent current, make these devices ideal for a variety of precision and portable applications. In addition, this device has a wide supply range with excellent PSRR, making it a suitable option for applications that are battery-powered without regulation.

7.2 Functional Block Diagram

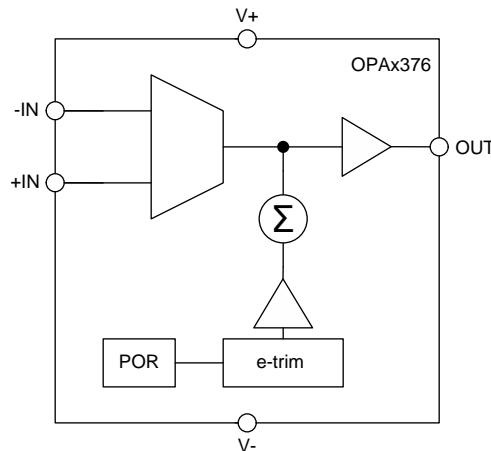

7.3 Feature Description

The OPAx376-Q1 family of precision amplifiers offers excellent dc performance as well as excellent ac performance. Operating from a single power-supply the OPAx376-Q1 is capable of driving large capacitive loads, has a wide input common-mode voltage range, and is well-suited to drive the inputs of successive-approximation response (SAR) analog-to-digital converters (ADCs) as well as 24-bit and higher resolution converters. Including internal ESD protection, the OPAx376-Q1 family is offered in a variety of industry-standard packages, including a wafer chip-scale package for applications that require space savings.

7.3.1 Operating Voltage

The OPAx376-Q1 family of amplifiers operate over a power-supply range of 2.2 V to 5.5 V (± 1.1 V to ± 2.75 V). Many of the specifications apply from -40°C to $+125^{\circ}\text{C}$. Parameters that can exhibit significant variance with regard to operating voltage or temperature are presented in the [Typical Characteristics](#) section.

7.3.2 Input Offset Voltage and Input Offset Voltage Drift

The OPAx376-Q1 family of operational amplifiers is manufactured using TI's *e-trim* technology. Each amplifier is trimmed in production, thereby minimizing errors associated with input offset voltage and input offset voltage drift. The *e-trim* technology is a TI proprietary method of trimming internal device parameters during either wafer probing or final testing.

7.3.3 Capacitive Load and Stability

The OPAx376-Q1 series of amplifiers may be used in applications where driving a capacitive load is required. As with all op amps, there may be specific instances where the OPAx376-Q1 can become unstable, leading to oscillation. The particular op amp circuit configuration, layout, gain, and output loading are some of the factors to consider when establishing whether an amplifier is be stable in operation. An op amp in the unity-gain (1 V/V) buffer configuration and driving a capacitive load exhibits a greater tendency to be unstable than an amplifier operated at a higher noise gain. The capacitive load, in conjunction with the op amp output resistance, creates a pole within the feedback loop that degrades the phase margin. The degradation of the phase margin increases as the capacitive loading increases.

Feature Description (continued)

The OPAx376 in a unity-gain configuration can directly drive up to 250 pF of pure capacitive load. Increasing the gain enhances the ability of the amplifier to drive greater capacitive loads; see the typical characteristic plot [Figure 16, Small-Signal Overshoot vs Load Capacitance](#). In unity-gain configurations, capacitive load drive can be improved by inserting a small (10-Ω to 20-Ω) resistor, R_S , in series with the output, as shown in [Figure 22](#). This resistor significantly reduces ringing while maintaining dc performance for purely capacitive loads. However, if there is a resistive load in parallel with the capacitive load, a voltage divider is created, introducing a gain error at the output and slightly reducing the output swing. The error introduced is proportional to the ratio R_S / R_L , and is generally negligible at low output current levels.

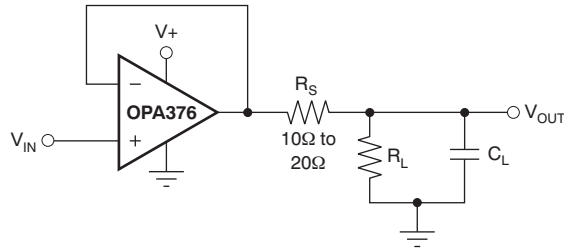

Figure 22. Improving Capacitive Load Drive

7.3.4 Common-Mode Voltage Range

The input common-mode voltage range of the OPAx376-Q1 series extends 100 mV beyond the supply rails. The offset voltage of the amplifier is very low, from approximately (V_-) to $(V_+) - 1$ V, as shown in [Figure 23](#). The offset voltage increases as common-mode voltage exceeds $(V_+) - 1$ V. Common-mode rejection is specified from (V_-) to $(V_+) - 1.3$ V.

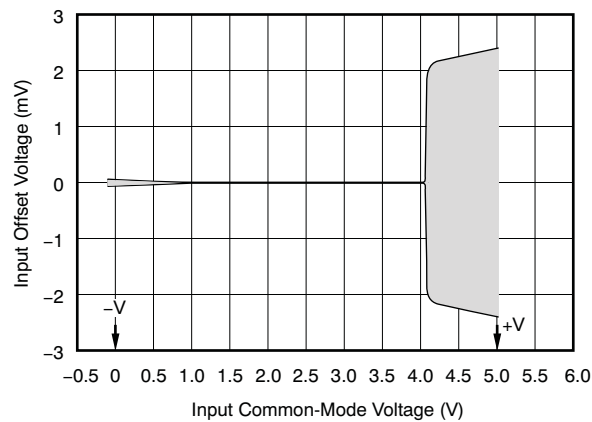

Figure 23. Offset and Common-Mode Voltage

Feature Description (continued)

7.3.5 Input and ESD Protection

The OPAx376-Q1 family incorporates internal electrostatic discharge (ESD) protection circuits on all pins. In the case of input and output pins, this protection primarily consists of current steering diodes connected between the input and power-supply pins. These ESD protection diodes also provide in-circuit, input overdrive protection, as long as the current is limited to 10 mA as stated in the [Absolute Maximum Ratings](#) table.

[Figure 24](#) shows how a series input resistor may be added to the driven input to limit the input current. The added resistor contributes thermal noise at the amplifier input and its value must be kept to a minimum in noise-sensitive applications.

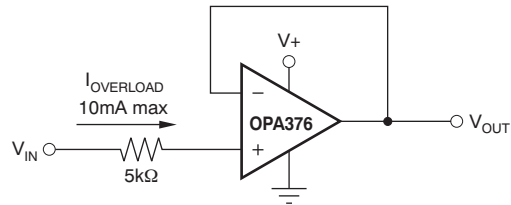

Figure 24. Input Current Protection

7.4 Device Functional Modes

The OPAx376-Q1 has a single functional mode and is operational when the power-supply voltage is greater than 2.2 V (± 1.1 V). The maximum power supply voltage for the OPAx376-Q1 is 5.5 V (± 2.75 V).

8 Application and Implementation

NOTE

Information in the following applications sections is not part of the TI component specification, and TI does not warrant its accuracy or completeness. TI's customers are responsible for determining suitability of components for their purposes. Customers should validate and test their design implementation to confirm system functionality.

8.1 Application Information

The OPAx376-Q1 family of operational amplifiers is built using *e-trim*, a proprietary technique in which offset voltage is adjusted during the final steps of manufacturing. This technique compensates for performance shifts that can occur during the molding process. Through *e-trim*, the OPAx376-Q1 family delivers excellent offset voltage (5 μV , typical). Additionally, the amplifier boasts a fast slew rate, low drift, low noise, and excellent PSRR and A_{OL} . These 5.5-MHz CMOS op amps operate on 760 μA (typical) quiescent current.

8.1.1 Basic Amplifier Configurations

The OPA376-Q1 family is unity-gain stable. It does not exhibit output phase inversion when the input is overdriven. A typical single-supply connection is shown in Figure 25. The OPA376-Q1 is configured as a basic inverting amplifier with a gain of -10 V/V . This single-supply connection has an output centered on the common-mode voltage, V_{CM} . For the circuit shown in Figure 25, this voltage is 2.5 V, but may be any value within the common-mode input voltage range.

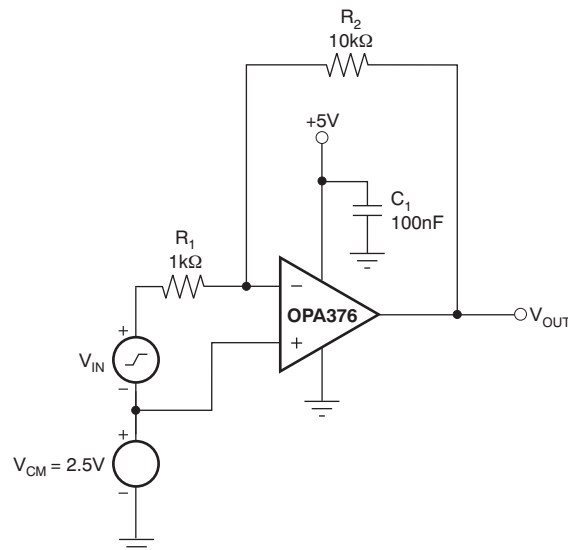

Figure 25. Basic Single-Supply Connection

Application Information (continued)

8.1.2 Active Filtering

The OPA376-Q1 series is well-suited for filter applications requiring a wide bandwidth, fast slew rate, low-noise, single-supply operational amplifier. Figure 26 shows a 50-kHz, second-order, low-pass filter. The components have been selected to provide a maximally-flat Butterworth response. Beyond the cutoff frequency, roll-off is -40 dB/dec. The Butterworth response is ideal for applications requiring predictable gain characteristics such as the anti-aliasing filter used ahead of an ADC.

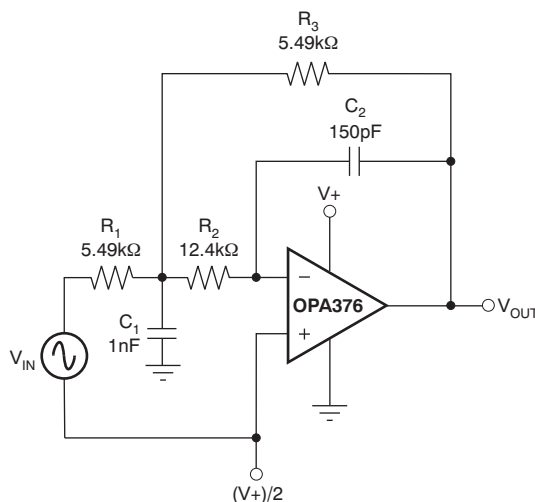
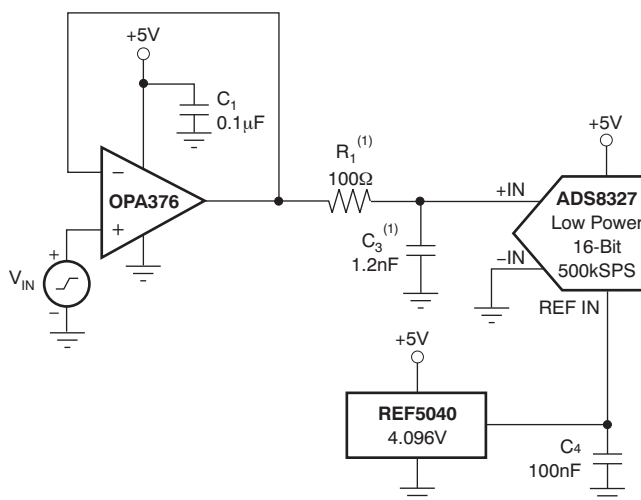

Figure 26. Second-Order Butterworth, 50-kHz Low-Pass Filter

8.1.3 Driving an Analog-to-Digital Converter

The low noise and wide gain bandwidth of the OPA376-Q1 family make it an ideal driver for ADCs. Figure 27 illustrates the OPA376-Q1 driving an ADS8327, 16-bit, 250-kSPS converter. The amplifier is connected as a unity-gain, noninverting buffer.



(1) Suggested value; may require adjustment based on specific application.

Figure 27. Driving an ADS8327

Application Information (continued)

8.1.4 Phantom-Powered Microphone

The circuit shown in Figure 28 depicts how a remote microphone amplifier can be powered by a phantom source on the output side of the signal cable. The cable serves double duty, carrying both the differential output signal from and dc power to the microphone amplifier stage.

An OPA2376-Q1 serves as a single-ended input to a differential output amplifier with a 6-dB gain. Common-mode bias for the two op amps is provided by the dc voltage developed across the electret microphone element. A 48-V phantom supply is reduced to 5.1 V by the series 6.8-k Ω resistors on the output side of the cable, and the 4.7-k Ω resistors and zener diode on the input side of the cable. AC coupling blocks the different dc voltage levels from each other on each end of the cable.

An INA163 instrumentation amplifier provides differential inputs and receives the balanced audio signals from the cable.

The INA163 gain may be set from 0 dB to 80 dB by selecting the R_G value. The INA163 circuit is typical of the input circuitry used in mixing consoles.

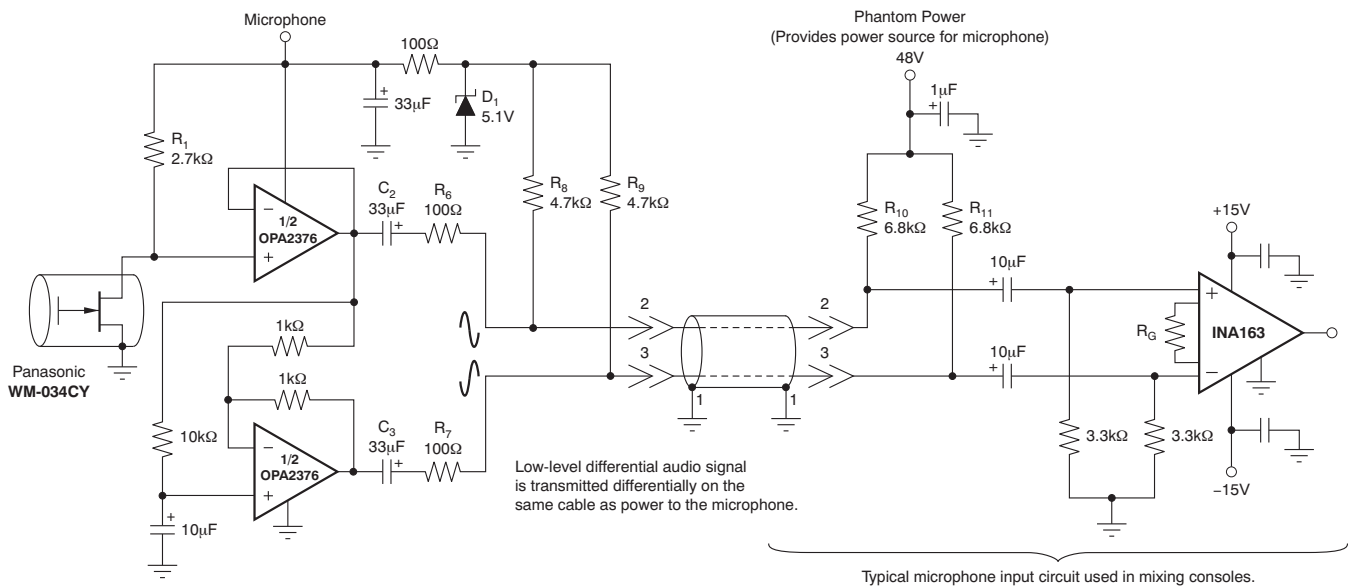
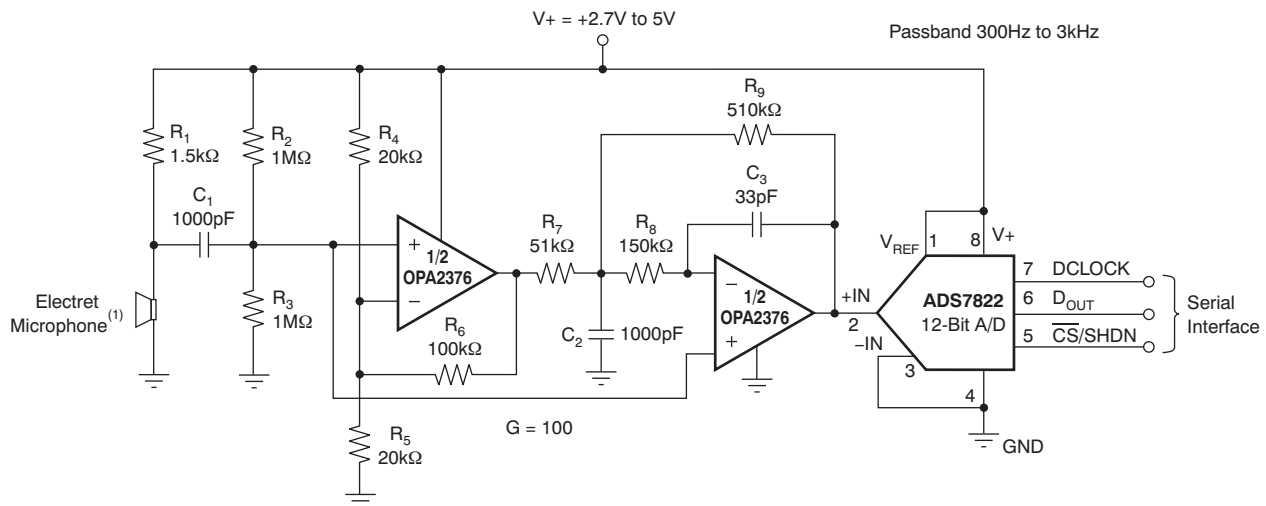

Figure 28. Phantom-Powered Electret Microphone

Figure 29 illustrates the OPA2376-Q1 driving a speech bandpass-filtered data acquisition system.



(1) Electret microphone powered by R₁.

Figure 29. OPA2376-Q1 as a Speech Bandpass-Filtered Data Acquisition System

8.2 Typical Application

Low-pass filters are commonly employed in signal processing applications to reduce noise and prevent aliasing. The OPA376-Q1 is ideally suited to construct high-speed, high-precision active filters. Figure 30 shows a second-order, low-pass filter commonly encountered in signal processing applications.

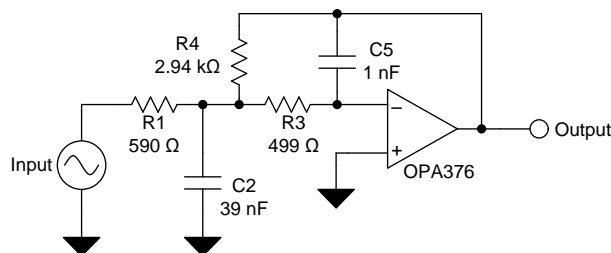

Figure 30. Typical Application Schematic

Typical Application (continued)

8.2.1 Design Requirements

Use the following parameters for this design example:

- Gain = 5 V/V (inverting gain)
- Low-pass cutoff frequency = 25 kHz
- Second-order Chebyshev filter response with 3-dB gain peaking in the passband

8.2.1.1 Detailed Design Procedure

The infinite-gain multiple-feedback circuit for a low-pass network function is shown in [Figure 30](#). Use [Equation 1](#) to calculate the voltage transfer function.

$$\frac{\text{Output}}{\text{Input}}(s) = \frac{-1/R_1 R_3 C_2 C_5}{s^2 + (s/C_2)(1/R_1 + 1/R_3 + 1/R_4) + 1/R_3 R_4 C_2 C_5} \quad (1)$$

This circuit produces a signal inversion. For this circuit, the gain at dc and the low-pass cutoff frequency are calculated by [Equation 2](#):

$$\text{Gain} = \frac{R_4}{R_1}$$

$$f_c = \frac{1}{2\pi} \sqrt{(1/R_3 R_4 C_2 C_5)} \quad (2)$$

Software tools are readily available to simplify filter design. [WEBENCH® Filter Designer](#) is a simple, powerful, and easy-to-use active filter design program. The WEBENCH Filter Designer lets you create optimized filter designs using a selection of TI operational amplifiers and passive components from TI's vendor partners.

Available as a web-based tool from the WEBENCH® Design Center, [WEBENCH® Filter Designer](#) allows you to design, optimize, and simulate complete multi-stage active filter solutions within minutes.

8.2.2 Application Curve

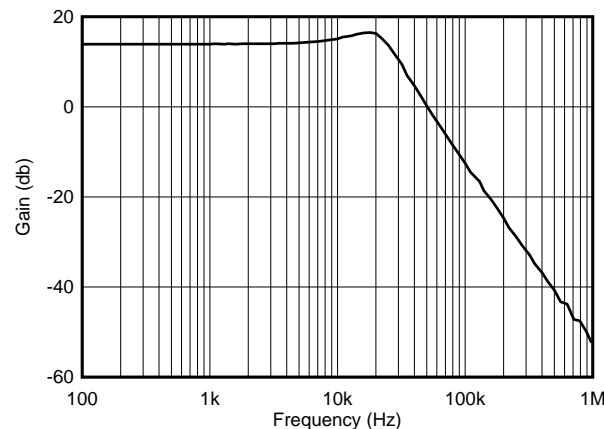

Figure 31. Low-Pass Filter Transfer Function

9 Power Supply Recommendations

The OPAx376-Q1 family of devices is specified for operation from 2.2 V to 5.5 V (± 1.1 V to ± 2.75 V); many specifications apply from -40°C to $+125^\circ\text{C}$. Parameters that can exhibit significant variance with regard to operating voltage or temperature are presented in the [Typical Characteristics](#) section.

10 Layout

10.1 Layout Guidelines

For best operational performance of the device, use good printed circuit board (PCB) layout practices, including:

- Noise can propagate into analog circuitry through the power pins of the circuit as a whole and op amp itself. Bypass capacitors are used to reduce the coupled noise by providing low-impedance power sources local to the analog circuitry.
 - Connect low-ESR, 0.1- μ F ceramic bypass capacitors between each supply pin and ground, placed as close to the device as possible. A single bypass capacitor from V+ to ground is applicable for single-supply applications.
- Separate grounding for analog and digital portions of circuitry is one of the simplest and most-effective methods of noise suppression. One or more layers on multilayer PCBs are usually devoted to ground planes. A ground plane helps distribute heat and reduces EMI noise pickup. Make sure to physically separate digital and analog grounds paying attention to the flow of the ground current. For more detailed information refer to the application report, *Circuit Board Layout Techniques*, [SLOA089](#).
- In order to reduce parasitic coupling, run the input traces as far away from the supply or output traces as possible. If these traces cannot be kept separate, crossing the sensitive trace perpendicular is much better as opposed to in parallel with the noisy trace.
- Place the external components as close to the device as possible. As shown in [Figure 32](#), keeping RF and RG close to the inverting input minimizes parasitic capacitance.
- Keep the length of input traces as short as possible. Always remember that the input traces are the most sensitive part of the circuit.
- Consider a driven, low-impedance guard ring around the critical traces. A guard ring can significantly reduce leakage currents from nearby traces that are at different potentials.
- Cleaning the PCB following board assembly is recommended for best performance.
- Any precision integrated circuit may experience performance shifts due to moisture ingress into the plastic package. Following any aqueous PCB cleaning process, baking the PCB assembly is recommended to remove moisture introduced into the device packaging during the cleaning process. A low temperature, post cleaning bake at 85°C for 30 minutes is sufficient for most circumstances.

10.2 Layout Example

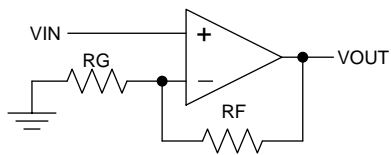

(Schematic Representation)

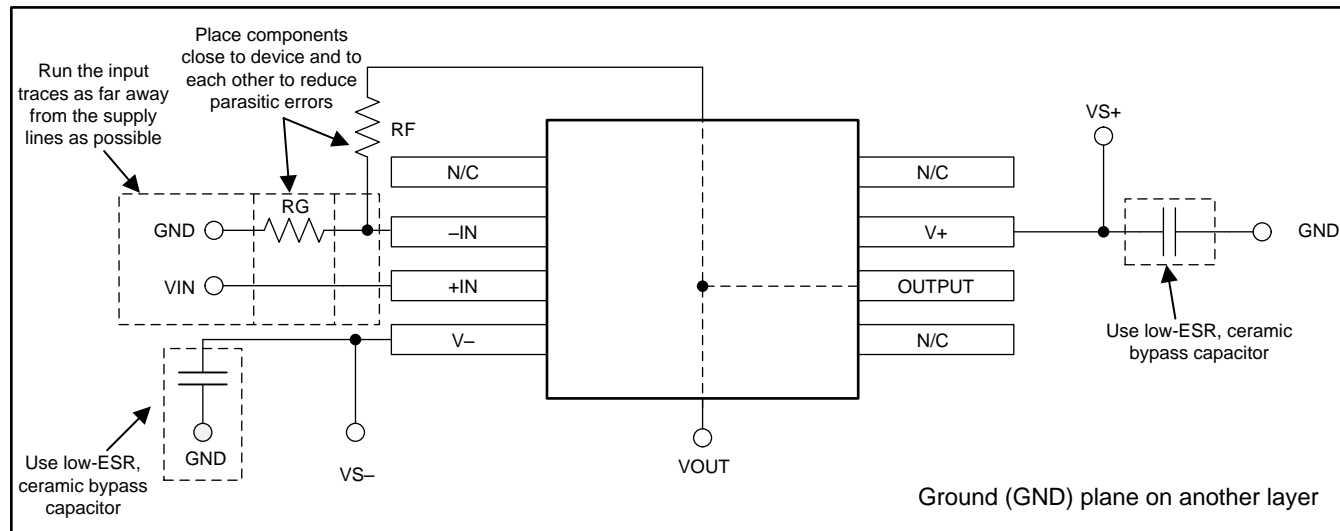

Figure 32. Layout Example

11 Device and Documentation Support

11.1 Device Support

11.1.1 Development Support

11.1.1.1 TINA-TI™ (Free Software Download)

TINA™ is a simple, powerful, and easy-to-use circuit simulation program based on a SPICE engine. TINA-TI is a free, fully-functional version of the TINA software, preloaded with a library of macro models in addition to a range of both passive and active models. TINA-TI provides all the conventional dc, transient, and frequency domain analysis of SPICE, as well as additional design capabilities.

Available as a [free download](#) from the Analog eLab Design Center, TINA-TI offers extensive post-processing capability that allows users to format results in a variety of ways. Virtual instruments offer the ability to select input waveforms and probe circuit nodes, voltages, and waveforms, creating a dynamic quick-start tool.

NOTE

These files require that either the TINA software (from DesignSoft™) or TINA-TI software be installed. Download the free TINA-TI software from the [TINA-TI folder](#).

11.1.1.2 TI Precision Designs

TI Precision Designs are analog solutions created by TI's precision analog applications experts and offer the theory of operation, component selection, simulation, complete PCB schematic and layout, bill of materials, and measured performance of many useful circuits. TI Precision Designs are available online at <http://www.ti.com/ww/en/analog/precision-designs/>.

11.1.1.3 WEBENCH® Filter Designer

WEBENCH® Filter Designer is a simple, powerful, and easy-to-use active filter design program. The WEBENCH® Filter Designer lets you create optimized filter designs using a selection of TI operational amplifiers and passive components from TI's vendor partners.

Available as a web-based tool from the WEBENCH® Design Center, [WEBENCH® Filter Designer](#) allows you to design, optimize, and simulate complete multistage active filter solutions within minutes.

11.2 Documentation Support

11.2.1 Related Documentation

For related documentation see the following:

- *Circuit Board Layout Techniques*, [SLOA089](#)
- *INA163: Low-Noise, Low-Distortion Instrumentation Amplifier*, [SBOS177](#)
- *Operational Amplifier Gain stability, Part 3: AC Gain-Error Analysis*, [SLYT383](#)
- *Operational Amplifier Gain Stability, Part 2: DC Gain-Error Analysis*, [SLYT374](#)
- *Op Amp Performance Analysis*, [SBOS054](#)
- *Shelf-Life Evaluation of Lead-Free Component Finishes*, [SZZA046](#)
- *Single-Supply Operation of Operational Amplifiers*, [SBOA059](#)
- *Tuning in Amplifiers*, [SBOA067](#)
- *Using Infinite-Gain, MFB Filter Topology in Fully Differential Active Filters*, [SLYT343](#)

11.3 Related Links

Table 1 lists quick access links. Categories include technical documents, support and community resources, tools and software, and quick access to sample or buy.

Table 1. Related Links

| PARTS | PRODUCT FOLDER | SAMPLE & BUY | TECHNICAL DOCUMENTS | TOOLS & SOFTWARE | SUPPORT & COMMUNITY |
|------------|----------------------------|----------------------------|----------------------------|----------------------------|----------------------------|
| OPA376-Q1 | Click here | Click here | Click here | Click here | Click here |
| OPA2376-Q1 | Click here | Click here | Click here | Click here | Click here |
| OPA4376-Q1 | Click here | Click here | Click here | Click here | Click here |

11.4 Community Resource

The following links connect to TI community resources. Linked contents are provided "AS IS" by the respective contributors. They do not constitute TI specifications and do not necessarily reflect TI's views; see TI's [Terms of Use](#).

TI E2E™ Online Community *TI's Engineer-to-Engineer (E2E) Community*. Created to foster collaboration among engineers. At e2e.ti.com, you can ask questions, share knowledge, explore ideas and help solve problems with fellow engineers.

Design Support *TI's Design Support* Quickly find helpful E2E forums along with design support tools and contact information for technical support.

11.5 Trademarks

e-trim, E2E are trademarks of Texas Instruments.
 TINA-TI is a trademark of Texas Instruments and DesignSoft, Inc.
 WEBENCH is a registered trademark of Texas Instruments.
 TINA, DesignSoft are trademarks of DesignSoft, Inc.
 All other trademarks are the property of their respective owners.

11.6 Electrostatic Discharge Caution



These devices have limited built-in ESD protection. The leads should be shorted together or the device placed in conductive foam during storage or handling to prevent electrostatic damage to the MOS gates.

11.7 Glossary

[SLYZ022](#) — *TI Glossary*.

This glossary lists and explains terms, acronyms, and definitions.

12 Mechanical, Packaging, and Orderable Information

The following pages include mechanical, packaging, and orderable information. This information is the most current data available for the designated devices. This data is subject to change without notice and revision of this document. For browser-based versions of this data sheet, refer to the left-hand navigation.

PACKAGING INFORMATION

| Orderable Device | Status (1) | Package Type | Package Drawing | Pins | Package Qty | Eco Plan (2) | Lead/Ball Finish (6) | MSL Peak Temp (3) | Op Temp (°C) | Device Marking (4/5) | Samples |
|------------------|---------------|--------------|-----------------|------|-------------|-------------------------|-------------------------|----------------------|--------------|-------------------------|-------------------------|
| OPA2376AQDRQ1 | ACTIVE | SOIC | D | 8 | 2500 | Green (RoHS & no Sb/Br) | CU NIPDAU | Level-2-260C-1 YEAR | -40 to 125 | 2376Q1 | Samples |
| OPA2376QDGKRQ1 | ACTIVE | VSSOP | DGK | 8 | 2500 | Green (RoHS & no Sb/Br) | CU NIPDAUAG | Level-2-260C-1 YEAR | -40 to 125 | 2376 | Samples |
| OPA376AQDBVRQ1 | ACTIVE | SOT-23 | DBV | 5 | 3000 | Green (RoHS & no Sb/Br) | CU NIPDAU | Level-2-260C-1 YEAR | -40 to 125 | OUHQ | Samples |
| OPA4376AQPWRQ1 | ACTIVE | TSSOP | PW | 14 | 2000 | Green (RoHS & no Sb/Br) | CU NIPDAU | Level-2-260C-1 YEAR | -40 to 125 | 4376Q1 | Samples |

(1) The marketing status values are defined as follows:

ACTIVE: Product device recommended for new designs.

LIFEBUY: TI has announced that the device will be discontinued, and a lifetime-buy period is in effect.

NRND: Not recommended for new designs. Device is in production to support existing customers, but TI does not recommend using this part in a new design.

PREVIEW: Device has been announced but is not in production. Samples may or may not be available.

OBSELETE: TI has discontinued the production of the device.

(2) **RoHS:** TI defines "RoHS" to mean semiconductor products that are compliant with the current EU RoHS requirements for all 10 RoHS substances, including the requirement that RoHS substance do not exceed 0.1% by weight in homogeneous materials. Where designed to be soldered at high temperatures, "RoHS" products are suitable for use in specified lead-free processes. TI may reference these types of products as "Pb-Free".

RoHS Exempt: TI defines "RoHS Exempt" to mean products that contain lead but are compliant with EU RoHS pursuant to a specific EU RoHS exemption.

Green: TI defines "Green" to mean the content of Chlorine (Cl) and Bromine (Br) based flame retardants meet JS709B low halogen requirements of <=1000ppm threshold. Antimony trioxide based flame retardants must also meet the <=1000ppm threshold requirement.

(3) MSL, Peak Temp. - The Moisture Sensitivity Level rating according to the JEDEC industry standard classifications, and peak solder temperature.

(4) There may be additional marking, which relates to the logo, the lot trace code information, or the environmental category on the device.

(5) Multiple Device Markings will be inside parentheses. Only one Device Marking contained in parentheses and separated by a "-" will appear on a device. If a line is indented then it is a continuation of the previous line and the two combined represent the entire Device Marking for that device.

(6) Lead/Ball Finish - Orderable Devices may have multiple material finish options. Finish options are separated by a vertical ruled line. Lead/Ball Finish values may wrap to two lines if the finish value exceeds the maximum column width.

Important Information and Disclaimer:The information provided on this page represents TI's knowledge and belief as of the date that it is provided. TI bases its knowledge and belief on information provided by third parties, and makes no representation or warranty as to the accuracy of such information. Efforts are underway to better integrate information from third parties. TI has taken and

continues to take reasonable steps to provide representative and accurate information but may not have conducted destructive testing or chemical analysis on incoming materials and chemicals. TI and TI suppliers consider certain information to be proprietary, and thus CAS numbers and other limited information may not be available for release.

In no event shall TI's liability arising out of such information exceed the total purchase price of the TI part(s) at issue in this document sold by TI to Customer on an annual basis.

OTHER QUALIFIED VERSIONS OF OPA2376-Q1, OPA376-Q1, OPA4376-Q1 :

- Catalog: [OPA2376](#), [OPA376](#), [OPA4376](#)

NOTE: Qualified Version Definitions:

- Catalog - TI's standard catalog product

TAPE AND REEL INFORMATION

QUADRANT ASSIGNMENTS FOR PIN 1 ORIENTATION IN TAPE

*All dimensions are nominal

| Device | Package Type | Package Drawing | Pins | SPQ | Reel Diameter (mm) | Reel Width W1 (mm) | A0 (mm) | B0 (mm) | K0 (mm) | P1 (mm) | W (mm) | Pin1 Quadrant |
|----------------|--------------|-----------------|------|------|--------------------|--------------------|---------|---------|---------|---------|--------|---------------|
| OPA2376AQDRQ1 | SOIC | D | 8 | 2500 | 330.0 | 12.4 | 6.4 | 5.2 | 2.1 | 8.0 | 12.0 | Q1 |
| OPA2376QDGKRQ1 | VSSOP | DGK | 8 | 2500 | 330.0 | 12.4 | 5.3 | 3.4 | 1.4 | 8.0 | 12.0 | Q1 |
| OPA376AQDBVRQ1 | SOT-23 | DBV | 5 | 3000 | 179.0 | 8.4 | 3.2 | 3.2 | 1.4 | 4.0 | 8.0 | Q3 |
| OPA4376AQPWRQ1 | TSSOP | PW | 14 | 2000 | 330.0 | 12.4 | 6.9 | 5.6 | 1.6 | 8.0 | 12.0 | Q1 |

TAPE AND REEL BOX DIMENSIONS

*All dimensions are nominal

| Device | Package Type | Package Drawing | Pins | SPQ | Length (mm) | Width (mm) | Height (mm) |
|----------------|--------------|-----------------|------|------|-------------|------------|-------------|
| OPA2376AQDRQ1 | SOIC | D | 8 | 2500 | 367.0 | 367.0 | 35.0 |
| OPA2376QDGKRQ1 | VSSOP | DGK | 8 | 2500 | 366.0 | 364.0 | 50.0 |
| OPA376AQDBVRQ1 | SOT-23 | DBV | 5 | 3000 | 195.0 | 200.0 | 45.0 |
| OPA4376AQPWRQ1 | TSSOP | PW | 14 | 2000 | 367.0 | 367.0 | 35.0 |

DBV0005A



PACKAGE OUTLINE

SOT-23 - 1.45 mm max height

SMALL OUTLINE TRANSISTOR

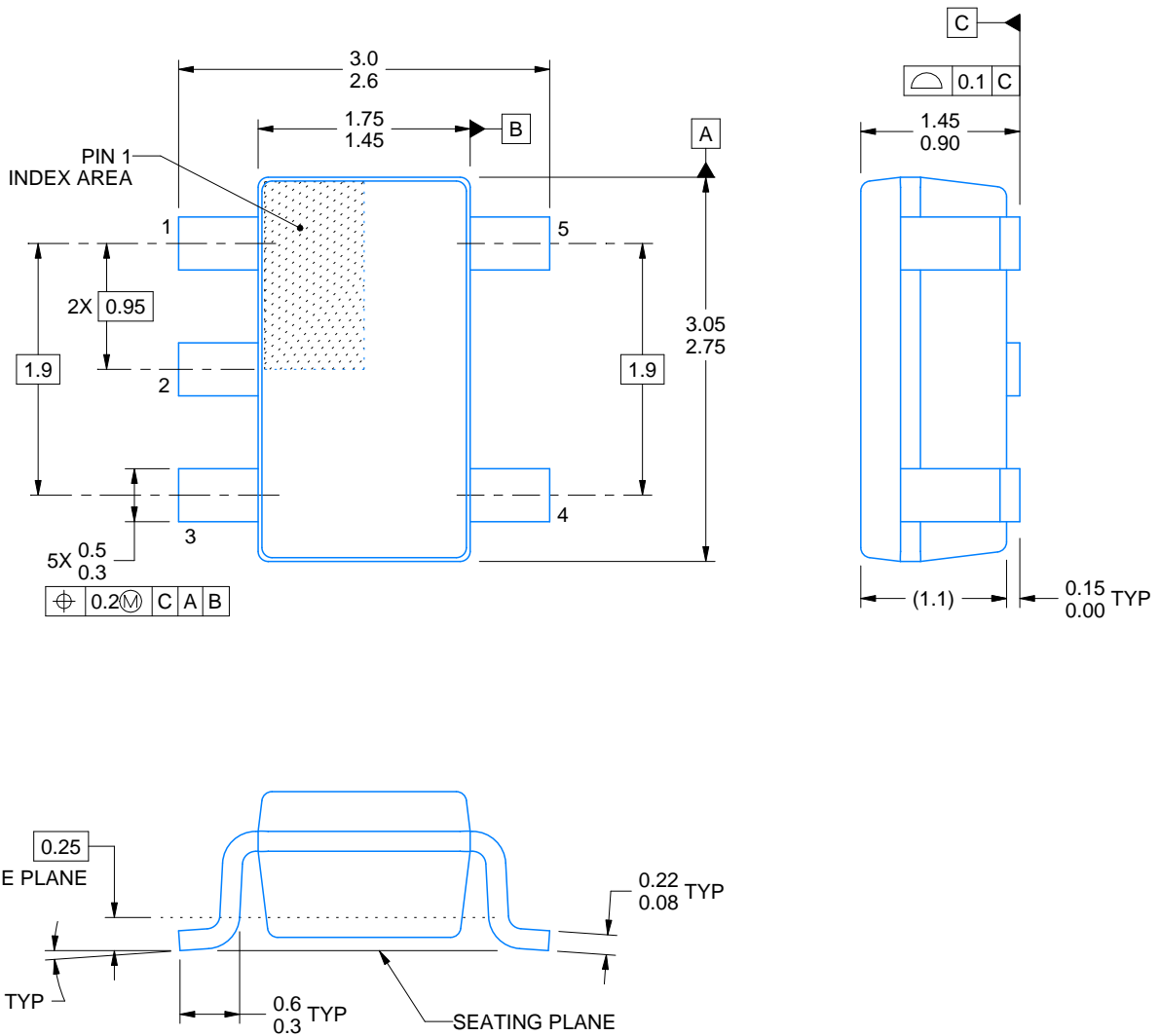

4214839/E 09/2019

NOTES:

1. All linear dimensions are in millimeters. Any dimensions in parenthesis are for reference only. Dimensioning and tolerancing per ASME Y14.5M.
2. This drawing is subject to change without notice.
3. Reference JEDEC MO-178.
4. Body dimensions do not include mold flash, protrusions, or gate burrs. Mold flash, protrusions, or gate burrs shall not exceed 0.15 mm per side.

EXAMPLE BOARD LAYOUT

DBV0005A

SOT-23 - 1.45 mm max height

SMALL OUTLINE TRANSISTOR



LAND PATTERN EXAMPLE
EXPOSED METAL SHOWN
SCALE:15X

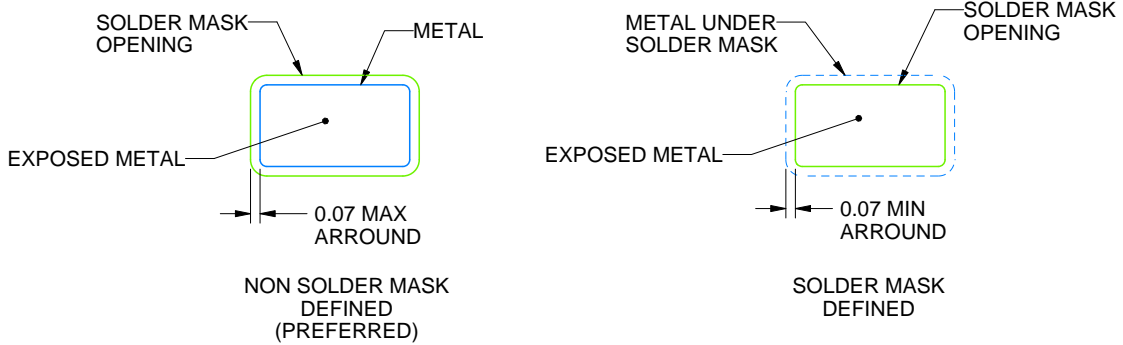

SOLDER MASK DETAILS

4214839/E 09/2019

NOTES: (continued)

- 5. Publication IPC-7351 may have alternate designs.
- 6. Solder mask tolerances between and around signal pads can vary based on board fabrication site.

EXAMPLE STENCIL DESIGN

DBV0005A

SOT-23 - 1.45 mm max height

SMALL OUTLINE TRANSISTOR



SOLDER PASTE EXAMPLE
BASED ON 0.125 mm THICK STENCIL
SCALE:15X

4214839/E 09/2019

NOTES: (continued)

7. Laser cutting apertures with trapezoidal walls and rounded corners may offer better paste release. IPC-7525 may have alternate design recommendations.
8. Board assembly site may have different recommendations for stencil design.

PW (R-PDSO-G14)

PLASTIC SMALL OUTLINE



4040064-3/G 02/11

- NOTES:
- A. All linear dimensions are in millimeters. Dimensioning and tolerancing per ASME Y14.5M-1994.
 - B. This drawing is subject to change without notice.
 - C. Body length does not include mold flash, protrusions, or gate burrs. Mold flash, protrusions, or gate burrs shall not exceed 0,15 each side.
 - D. Body width does not include interlead flash. Interlead flash shall not exceed 0,25 each side.
 - E. Falls within JEDEC MO-153

PW (R-PDSO-G14)

PLASTIC SMALL OUTLINE



4211284-2/G 08/15

- NOTES:
- A. All linear dimensions are in millimeters.
 - B. This drawing is subject to change without notice.
 - C. Publication IPC-7351 is recommended for alternate designs.
 - D. Laser cutting apertures with trapezoidal walls and also rounding corners will offer better paste release. Customers should contact their board assembly site for stencil design recommendations. Refer to IPC-7525 for other stencil recommendations.
 - E. Customers should contact their board fabrication site for solder mask tolerances between and around signal pads.



D0008A

PACKAGE OUTLINE

SOIC - 1.75 mm max height

SMALL OUTLINE INTEGRATED CIRCUIT



4214825/C 02/2019

NOTES:

- Linear dimensions are in inches [millimeters]. Dimensions in parenthesis are for reference only. Controlling dimensions are in inches. Dimensioning and tolerancing per ASME Y14.5M.
- This drawing is subject to change without notice.
- This dimension does not include mold flash, protrusions, or gate burrs. Mold flash, protrusions, or gate burrs shall not exceed .006 [0.15] per side.
- This dimension does not include interlead flash.
- Reference JEDEC registration MS-012, variation AA.

EXAMPLE STENCIL DESIGN

D0008A

SOIC - 1.75 mm max height

SMALL OUTLINE INTEGRATED CIRCUIT



SOLDER PASTE EXAMPLE
BASED ON .005 INCH [0.125 MM] THICK STENCIL
SCALE:8X

4214825/C 02/2019

NOTES: (continued)

8. Laser cutting apertures with trapezoidal walls and rounded corners may offer better paste release. IPC-7525 may have alternate design recommendations.
9. Board assembly site may have different recommendations for stencil design.



- NOTES:
- A. All linear dimensions are in millimeters.
 - B. This drawing is subject to change without notice.
 - C. Publication IPC-7351 is recommended for alternate designs.
 - D. Laser cutting apertures with trapezoidal walls and also rounding corners will offer better paste release. Customers should contact their board assembly site for stencil design recommendations. Refer to IPC-7525 for other stencil recommendations.
 - E. Customers should contact their board fabrication site for solder mask tolerances between and around signal pads.

IMPORTANT NOTICE AND DISCLAIMER

TI PROVIDES TECHNICAL AND RELIABILITY DATA (INCLUDING DATASHEETS), DESIGN RESOURCES (INCLUDING REFERENCE DESIGNS), APPLICATION OR OTHER DESIGN ADVICE, WEB TOOLS, SAFETY INFORMATION, AND OTHER RESOURCES "AS IS" AND WITH ALL FAULTS, AND DISCLAIMS ALL WARRANTIES, EXPRESS AND IMPLIED, INCLUDING WITHOUT LIMITATION ANY IMPLIED WARRANTIES OF MERCHANTABILITY, FITNESS FOR A PARTICULAR PURPOSE OR NON-INFRINGEMENT OF THIRD PARTY INTELLECTUAL PROPERTY RIGHTS.

These resources are intended for skilled developers designing with TI products. You are solely responsible for (1) selecting the appropriate TI products for your application, (2) designing, validating and testing your application, and (3) ensuring your application meets applicable standards, and any other safety, security, or other requirements. These resources are subject to change without notice. TI grants you permission to use these resources only for development of an application that uses the TI products described in the resource. Other reproduction and display of these resources is prohibited. No license is granted to any other TI intellectual property right or to any third party intellectual property right. TI disclaims responsibility for, and you will fully indemnify TI and its representatives against, any claims, damages, costs, losses, and liabilities arising out of your use of these resources.

TI's products are provided subject to TI's Terms of Sale (www.ti.com/legal/termsofsale.html) or other applicable terms available either on ti.com or provided in conjunction with such TI products. TI's provision of these resources does not expand or otherwise alter TI's applicable warranties or warranty disclaimers for TI products.

Mailing Address: Texas Instruments, Post Office Box 655303, Dallas, Texas 75265
Copyright © 2019, Texas Instruments Incorporated