

DATA SHEET

SUNGMUN CODE : STP-1152 SERIES

DESCRIPTION : TACT SWITCH

SUNGMUN ELECTRONICS CO., LTD.

Address 301-302, Bucheon Technopark 345, Seokcheon-ro, Ojeong-gu
Bucheon-si, Gyeonggi-do, Korea

TEL. +82-32-328-1941~4

FAX +82-32-328-1945

E-mail sungmun@sungmun.co.kr

Website www.sungmun.com



SUNGMUN
ELECTRONICS

MRK	DATE	REVISION	SIGN
△			

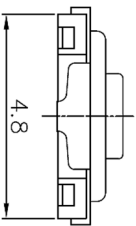
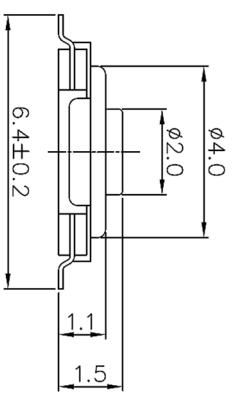
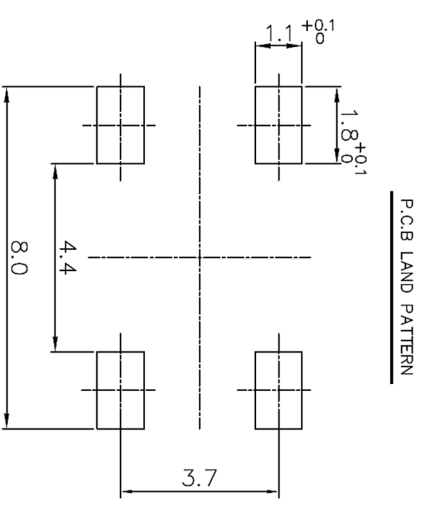
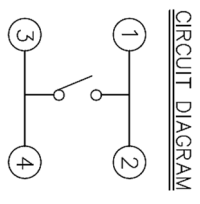
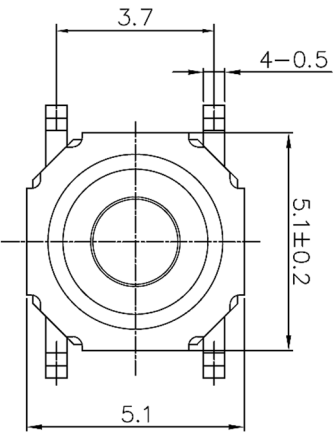

SPECIFICATION

1. RATING : DC 12V 50mA
2. TRAVEL : 0.2 ±0.1mm
3. CONTACT RESISTANCE : 100mΩ MAX.
4. BOUNCE : 10m SEC MAX.

MODEL	OPERATING FORCE	LIFE CYCLES
STP-1152	160±50gf	1,000,000 CYCLE
STP-1152S	250±50gf	200,000 CYCLE

01	-																		
NO.	DESCRIPTION	CHECKED	APPROVED	MATERIAL	COLOR/FINISH	Q.TY	VENDOR												
DRAW/DESIGNED																			
Y.N JEON	S.M PARK	J.P ROH																	
2019-03-20																			
SUNGMIN ELECTRONICS CO.,LTD																			
UNIT	SCALE	MODEL	DRAW NO.	SIZE	SHEET														
mm	±0.1	STP-1152X	STP-11520-S-01		1/1														

1. Description:

This specification covers the requirements for single key switches which have no key top(Tact switches mechanical contact).

1-1 Operating Temperature Range : -40°C ~ +70°C (normal humidity, normal press)

1-2 Test Conditions :

Tests and measurements shall be made in the following standard conditions unless otherwise specified :

Normal temperature (temperature 5 to 35°C)

Normal humidity (relative humidity 45 to 85%)

Normal pressure (pressure 860 to 1,060 mbars)

In case any question arises from the judgment made, tests shall be conducted in the following conditions:

Temperature (20±2°C)

Relative humidity (65±5%)

Pressure (860 to 1,060 mbars)

2. Rating:

2-1 Maximum Rating : 50 mA, DC 12V

3. Type of Actuation : PUSH-ON Type

4. Contact Arrangement : 1 poles 1 throws (SPST)

5. Electrical Characteristics

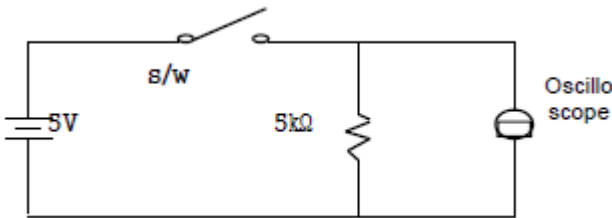
ITEM	DESCRIPTION	TEST CONDITIONS	REQUIREMENTS
5-1	Visual Examination	By visual examination check without any out pressure & testing.	There shall be no defects that affect the serviceability of the product.
5-2	Contact Resistance	Push force : (Operation force) X 2 Measurements shall be made with a 1kHz small current contact resistance.	100mΩ max.
5-3	Insulation Resistance	D.C 100V for 1 minute. (Between terminals)	100 MΩ min.
5-4	Dielectric withstanding Voltage	A.C 250V for 1 minute. (Between terminals)	There shall be no breakdown
5-5	Bounce	<p>Operation speed : 3~4 time / sec</p> 	10ms max.

6. Mechanical Characteristics

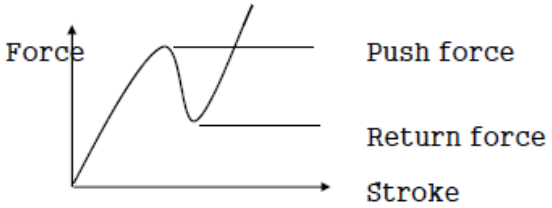
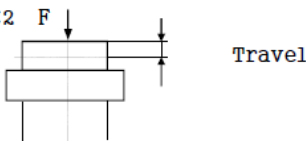
ITEM	DESCRIPTION	TEST CONDITIONS	REQUIREMENTS
6-1	Operating Force	Push by recommended operating condition.  <p>Force</p> <p>Stroke</p> <p>Push force</p> <p>Return force</p>	See outside drawing
6-2	Travel	Push by recommended operating condition. $F = (\text{Operation force}) \times 2$  <p>Travel</p>	See outside drawing
6-3	Stop Strength	A static load of 3 kgf shall be applied in the direction of stem operation for a period of 60 seconds.	No damage (Electrical and mechanical)
6-3	Stem Strength	The maximum force to withstand a pull applied opposite to the direction of stem operation shall be measured.	0.5 kgf min
6-5	Operation Life	Measurements shall be made following the test set forth below: 1) 50mA, 12V DC resistive load 2) Rate of operation: 2~3 cycles/ sec 3) Depression: Maximum value of operation force 4) Cycles of operation: See outside drawing	1)As shown in item 5-3, 5-4, 6-2 2)Contact Resistance: 200mΩ max 3)Bounce: 20m sec max 4)Actuating force: ±30% initial force

7. Environmental Characteristics

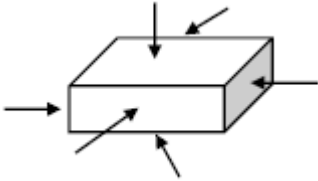
ITEM	DESCRIPTION	TEST CONDITIONS	REQUIREMENTS
7-1	Moisture Resistance	<p>Following the test set forth below the sample shall be left in normal temperature and humidity conditions for one hour before measurements. Are made :</p> <p>1) Temperature : $60 \pm 2^{\circ}\text{C}$ 2) Relative humidity : 90 to 95% 3) Time : 96 hours</p> <p>Water drops shall be removed.</p>	<p>1)As shown in item 5-3, 5-4, 5-5, 6-1, 6-2</p> <p>2)Contact Resistance: 200mΩ max.</p>
7-2	Resistance Low Temperature	<p>Following the test set forth below the sample shall be left in normal temperature and humidity conditions for an hour before measurements are made:</p> <p>1)Temperature: $-40^{\circ}\text{C} \pm 2^{\circ}\text{C}$ 2)Time: 96 hours</p> <p>Water drops shall be removed.</p>	<p>1)As shown in item 5-3, 5-4, 5-5, 6-1, 6-2</p> <p>2)Contact Resistance: 200mΩ max.</p>
7-3	Resistance High Temperature	<p>Following the test set forth below the sample shall be left in normal temperature and humidity conditions for an hour before measurements are made:</p> <p>1)Temperature: $80^{\circ}\text{C} \pm 2^{\circ}\text{C}$ 2)Time: 96 hours</p>	<p>1)As shown in item 5-3, 5-4, 5-5, 6-1, 6-2</p> <p>2)Contact Resistance: 200mΩ max.</p>
7-4	Impact Shock Resistance	<p>Measurements shall be made following the test set forth below :</p> <p>1) Acceleration : 80G 2) Cycles of test : 3 cycles each in 6 directions, for a total of 18 cycles.</p> <div style="text-align: center;">  </div>	<p>Item 5 Item 6-1, 6-2</p>

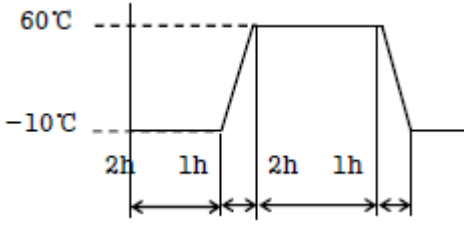
ITEM	DESCRIPTION	TEST CONDITIONS	REQUIREMENTS
7-5	Change of Temperature	<p>Following ten cycles of high temperature test. The sample shall be placed in normal temperature and humidity conditions for one hour before measurements are made. During this test, water drops shall be removed.</p>  <p style="text-align: center;">Cycling : 5 cycle</p>	<p>1)As shown in item 5-3, 5-4, 5-5, 6-1, 6-2</p> <p>2)Contact Resistance: 200mΩ max.</p>
7-6	Salt mist Test	<p>Switch shall be checked after following test.</p> <ol style="list-style-type: none"> 1) Salt solution: 5±1% 2) Temperature: 35±2°C 3) Time: 48 hours 	Without excessive rust or discoloration
7-7	Vibration Resistance	<p>Measurements shall be made following the test set forth below :</p> <ol style="list-style-type: none"> 1) Range of oscillation : 10 to 55Hz 2) Amplitude, peak to peak : 1.5mm 3) Cycle of sweep : 10-55-10Hz in a minute. 4) Mode of sweep : Logarithmically seep or uniform sweep. 5) Direction of oscillation : Three mutually perpendicular direction, including the direction of stem travel. 6) 2 hours each for a total of 6 hours. 	<p>Item 5</p> <p>Item 6-1, 6-2</p>
7-8	Soldering Test	<p>Soldering area: t/2 of P.W.B thickness (P.W.B : t = 1.6)</p> <p>Soldering temperature: 260±5°C</p> <p>Soldering time: 5±1 sec</p>	<p>No damage (Electrical and mechanical)</p>

8. This item is "RoHS" Compliant

9. Reflow Soldering Conditions:

9-1 Preheat : Temperature on the copper foil surface should reach 180°C, 2±0.3 minutes after the P.W.B entered into the soldering equipment.

9-2 Soldering heat : Temperature on the copper foil surface should reach the peak temperature of 260°C within 40 seconds after the P.W.B entered into soldering heat zone.

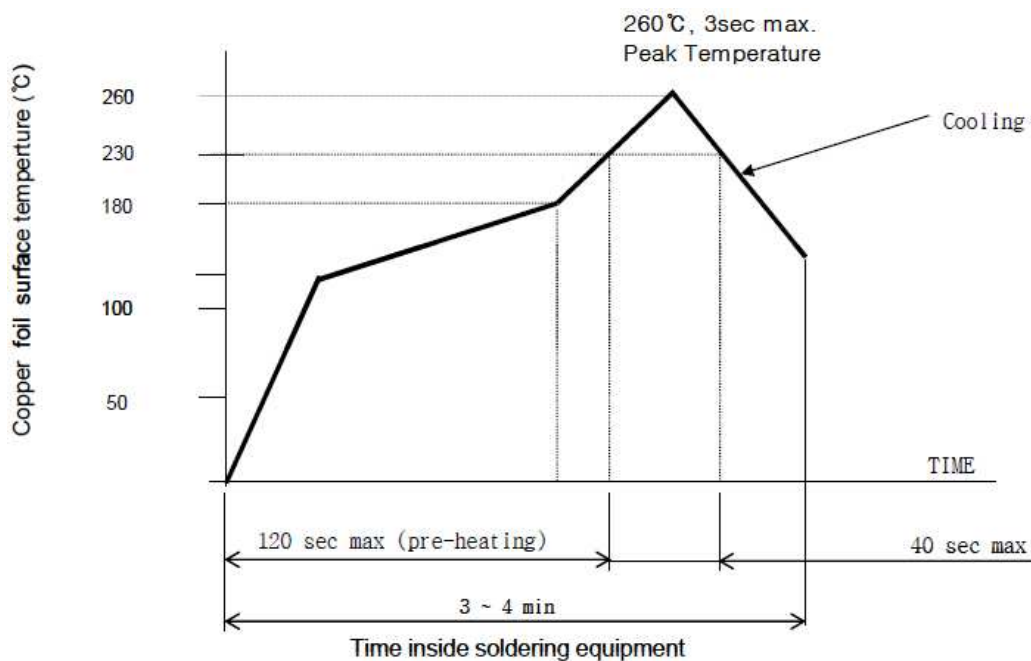

Temperature Profile