

規格承認書

PECIFICATION FOR APPROVAL

客戶

CUSTOMER : 立創

項目

ITEM : 压电式无源蜂鸣器 (外部驱动)

型號

TYPE : GPC1205YB-5V4000

描述

DESCRIPTION : D12 x H 5.5 MM 4000Hz 11000pF 5V >=80DB PBT 材质 P=6.5 MM

客戶料號

CUSTOMER NO. :

規格書號

SPECIFICATION NO.:

版本

EDITION NO. : V1.1

日期

DATE : 2019-12-26

客戶承認

CUSTOMER CONFIRM AND SIGN

檢查 TESTED BY	審核 CHECKED BY	承認 APPROVED BY

東莞市贏海電子有限公司

DONGUAN INGHAI ELECTRONICS CO.,LTD

製作 ISSUED BY	審查 CHECKED BY	確認 APPROVED BY
周明	李林	

地址：廣東省東莞市長安鎮上沙第五工业区新春 1 路新春科技园

電話 / TEL: 0769-83060958 傳真 / FAX: 0769-81608993

網址: [HTTP://WWW.INGHAI.COM](http://www.inghai.com)

DONGGUAN INGHAI ELECTRONICS CO.,LTD

Model NO: GPC1205YB-5V4000

DIMENSIONS Unit:mm

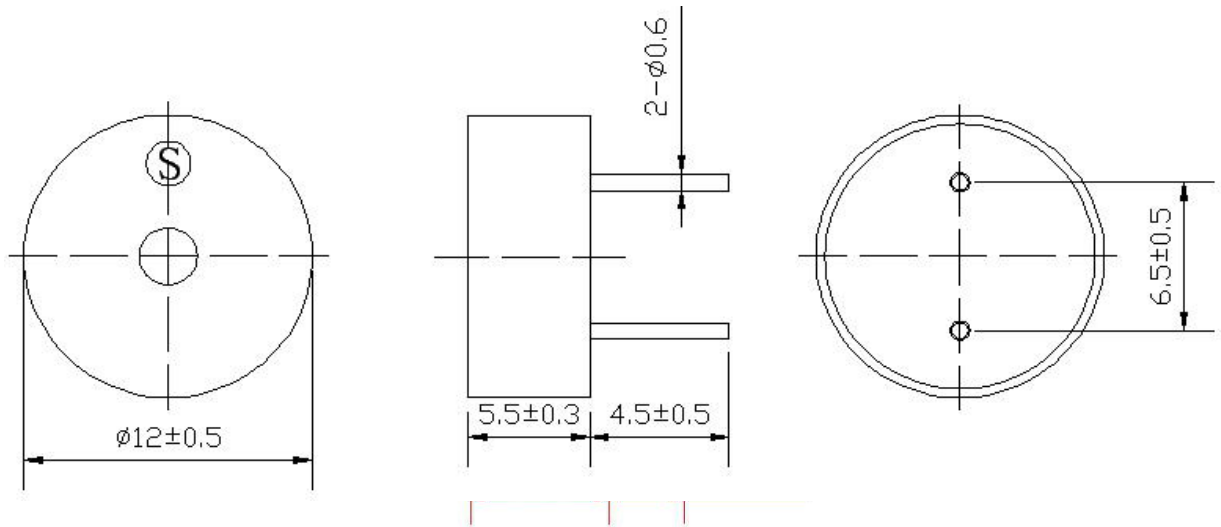

A: SPECIFICATIONS

Model NO	GPC1205YB-5V4000
Min Sound Pressure Level	80dB at 4KHZ at 5Vp-p at 10cm
Resonant Frequency	4000 +/-500 Hz
Rated Current	Max. 3mA
Capacitance at 1KHz	11000pF+30%
Rated Voltage	5Vp-p
Operating Voltage	3~25 Vp-p
Operating Temperature	-20 °C~+70 °C
Storage Temperature	-30 °C~+80 °C
Case material and color	PBT / Black

Measuring condition

Part shall be measured under a condition (Temperature: 5~35°C, Humidity: 45%~85%R.H., Atmospheric pressure: 860 ~ 1060hPa) unless the standard condition (Temperature: 25±3°C, Humidity: 60±10%R.H.)

Atmospheric pressure: 860 ~ 1060hPa) is regulated to measure.

B: Acoustic Characteristics:

The oscillation frequency, current consumption and sound pressure are measured by the measuring instruments shown below

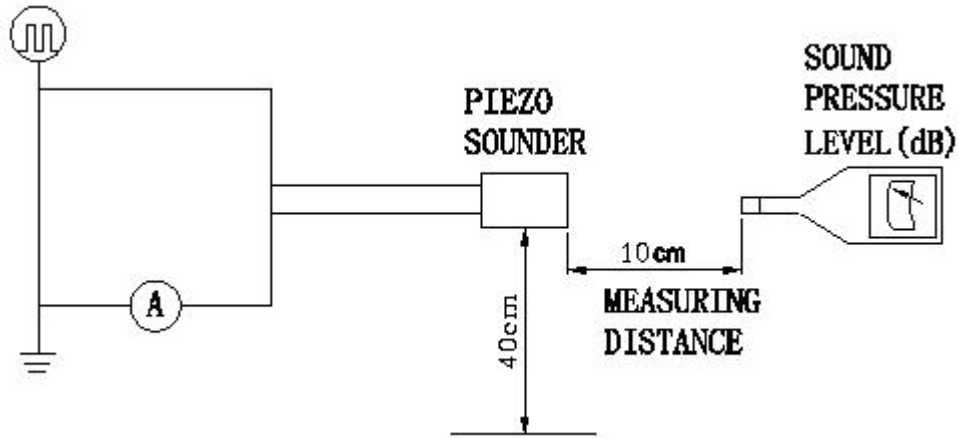

C: Typical Frequency Response Curve

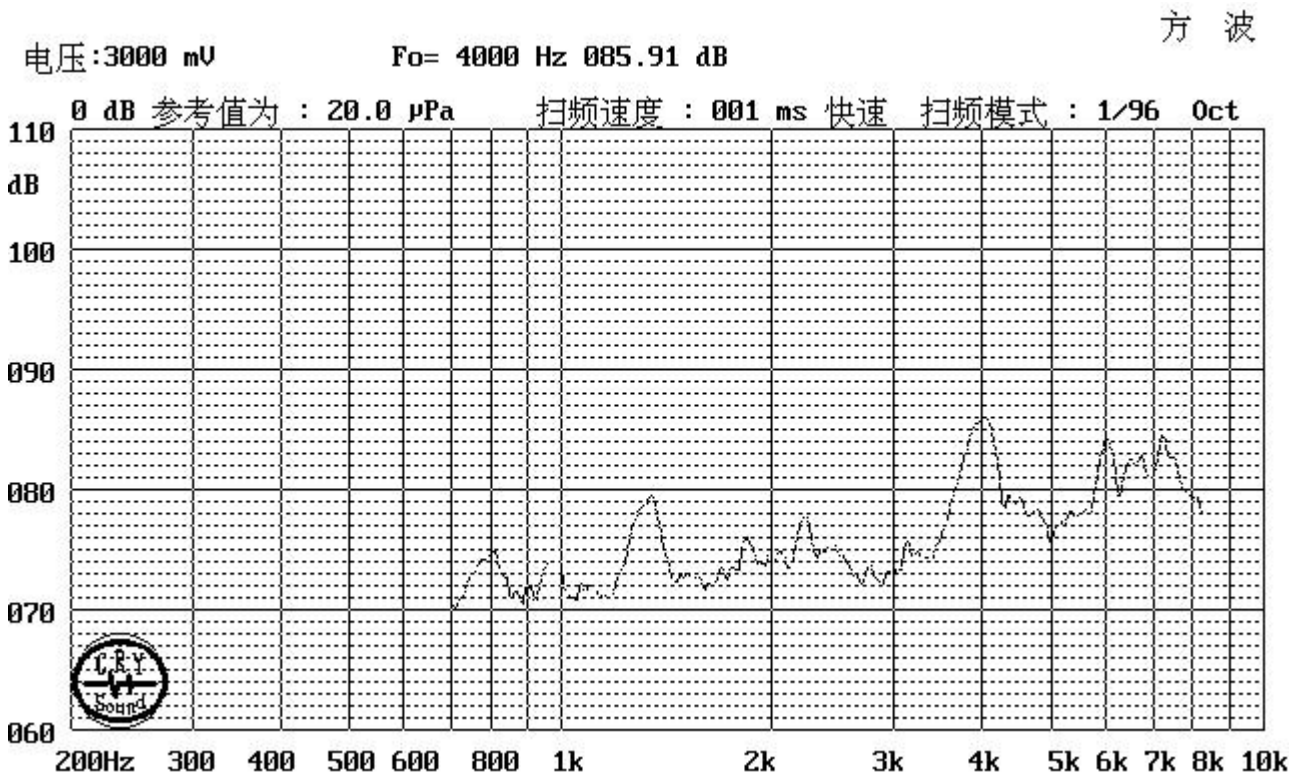

D: Reliability Test

After any following tests the part shall meet specifications without any degradation in appearance and performance except SPL. SPL shall not deviate more than -10 dB from the initial value

1. Ordinary Temperature Life Test

The part shall be subjected to 96 hours at $25 \pm 10^\circ\text{C}$. Input rated voltage Resonant frequency, 1/2 duty Square wave.

2. High Temperature Test

The part shall be capable of with standing a storage temperature of $+80^\circ\text{C}$ for 96 hours.

3. Low Temperature Test

The part shall be capable of with standing a storage temperature of -30°C for 96 hours.

4. Humidity Test

Temperature: $+40^\circ\text{C} \pm 3^\circ\text{C}$ Relative Humidity: 90% ~ 95% Duration: 48 hours and expose to room temperature for 6 hours

5. Temperature Shock Test

Temperature: 70°C /1hour → 25°C /3hours → -30°C /1hour → 25°C /3hours (1cycle)
Total cycle: 10 cycles

6. Drop Test

Standard Packaging From 120mm (Drop on hard wood or board of 5cm thick, three sides, six plain.)

7. Vibration Test

Vibration: 1000cycles /min. Amplitude: 1.5mm, Duration: 1 hour in each 3 axes

Note:

As this product is not protected from foreign material entering, please make sure that any foreign materials (e.g. magnetic powder, washing solvent, flux, corrosive gas) do not enter this product in your production processes. The functional degradation (e.g. SPL down) may occur if foreign material enter it.