







Lonten N-channel 650V, 20A, 0.18Ω LonFET™ Power MOSFET

<p>Description LonFET™ Power MOSFET is fabricated using advanced super junction technology. The resulting device has extremely low on resistance, making it especially suitable for applications which require superior power density and outstanding efficiency.</p> <p>Features</p> <ul style="list-style-type: none"> ◆ Ultra low $R_{DS(on)}$ ◆ Ultra low gate charge (typ. $Q_g = 39\text{nC}$) ◆ 100% UIS tested ◆ RoHS compliant <p>Applications</p> <ul style="list-style-type: none"> ◆ Power factor correction (PFC). ◆ Switched mode power supplies (SMPS). ◆ Uninterruptible power supply (UPS). 	<p>Product Summary</p> <p>$V_{DS} @ T_{j,max}$ 700V</p> <p>$R_{DS(on),max}$ 0.18Ω</p> <p>I_{DM} 60A</p> <p>$Q_{g,typ}$ 39nC</p> <div style="display: flex; justify-content: space-around; align-items: center;">      </div> <p style="text-align: center;"> TO-247 TO-220MF TO-263 TO-220 TO-262 </p> <div style="text-align: center;">  <p>N-Channel MOSFET</p> </div> <div style="text-align: right;">  </div>
----------------------------------------------------------------------------------------------------------------------------------------------------------------------------------------------------------------------------------------------------------------------------------------------------------------------------------------------------------------------------------------------------------------------------------------------------------------------------------------------------------------------------------------------------------------------------------------------------------------------------------------------------------------------------------------------------------------------------------------	------------------------------------------------------------------------------------------------------------------------------------------------------------------------------------------------------------------------------------------------------------------------------------------------------------------------------------------------------------------------------------------------------------------------------------------------------------------------------------------------------------------------------------------------------------------------------------------------------------------------------------------------------------------------------------------------------------------------------------------------------------------------------------------------------------------------------------------------------------------------------------------------------------------------------------------------------------------------------------------------------------------------------------------------------------------------------------------------------------------------------------------------------------------------------------------------------------------------

Absolute Maximum Ratings

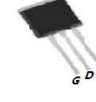
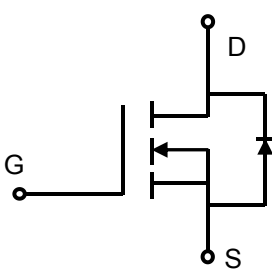
Parameter	Symbol	Value	Unit
Drain-Source Voltage	V_{DSS}	650	V
Continuous drain current ($T_C = 25^\circ\text{C}$) ($T_C = 100^\circ\text{C}$)	I_D	20	A
		13	A
Pulsed drain current ¹⁾	I_{DM}	60	A
Gate-Source voltage	V_{GSS}	± 30	V
Avalanche energy, single pulse ²⁾	E_{AS}	600	mJ
Avalanche energy, repetitive ³⁾	E_{AR}	0.4	mJ
Avalanche current, repetitive ³⁾	I_{AR}	20	A
Power Dissipation TO-247/TO-263/TO-262/TO-220 ($T_C = 25^\circ\text{C}$) - Derate above 25°C	P_D	205	W
		1.64	W/ $^\circ\text{C}$
Power Dissipation TO-220MF ($T_C = 25^\circ\text{C}$) - Derate above 25°C	P_D	34	W
		0.28	W/ $^\circ\text{C}$
Mounting torque To-220MF (M2.5 screws)		50	Ncm
Operating and Storage Temperature Range	T_J, T_{STG}	-55 to +150	$^\circ\text{C}$
Continuous diode forward current	I_S	20	A
Diode pulse current	$I_{S,pulse}$	60	A

Thermal Characteristics TO-247/TO-263/TO-262/TO-220

Parameter	Symbol	Value	Unit
Thermal Resistance, Junction-to-Case	$R_{\theta JC}$	0.61	$^{\circ}C/W$
Thermal Resistance, Junction-to-Ambient	$R_{\theta JA}$	60	$^{\circ}C/W$
Soldering temperature, wavesoldering only allowed at leads. (1.6mm from case for 10s)	T_{sold}	260	$^{\circ}C$

Thermal Characteristics TO-220MF

Parameter	Symbol	Value	Unit
Thermal Resistance, Junction-to-Case	$R_{\theta JC}$	3.6	$^{\circ}C/W$
Thermal Resistance, Junction-to-Ambient	$R_{\theta JA}$	80	$^{\circ}C/W$
Soldering temperature, wavesoldering only allowed at leads. (1.6mm from case for 10s)	T_{sold}	260	$^{\circ}C$

Package Marking and Ordering Information

Device	Device Package	Marking	Units/Tube	Units/Real
LSB65R180GF	TO-247	LSB65R180GF	30	
LSC65R180GF	TO-220	LSC65R180GF	50	
LSD65R180GF	TO-220MF	LSD65R180GF	50	
LSE65R180GF	TO-263-2L	LSE65R180GF		800
LSF65R180GF	TO-262	LSF65R180GF	50	

Electrical Characteristics $T_c = 25^{\circ}C$ unless otherwise noted

Parameter	Symbol	Test Condition	Min.	Typ.	Max.	Unit
Static characteristics						
Drain-source breakdown voltage	BV_{DSS}	$V_{GS}=0V, I_D=0.25mA$	650	-	-	V
Gate threshold voltage	$V_{GS(th)}$	$V_{DS}=V_{GS}, I_D=0.25mA$	2	3.5	5	V
Drain cut-off current	I_{DSS}	$V_{DS}=650V, V_{GS}=0V,$ $T_j = 25^{\circ}C$ $T_j = 125^{\circ}C$	-	-	1	μA
			-	10	-	
Gate leakage current, Forward	I_{GSSF}	$V_{GS}=30V, V_{DS}=0V$	-	-	100	nA
Gate leakage current, Reverse	I_{GSSR}	$V_{GS}=-30V, V_{DS}=0V$	-	-	-100	nA
Drain-source on-state resistance	$R_{DS(on)}$	$V_{GS}=10V, I_D=10A$ $T_j = 25^{\circ}C$ $T_j = 150^{\circ}C$	-	-	-	Ω
			-	0.16	0.18	
			-	0.4	-	
Gate resistance	R_G	$f=1MHz, \text{open drain}$	-	4.4	-	Ω
Dynamic characteristics						
Input capacitance	C_{iss}	$V_{DS} = 25V, V_{GS} = 0V,$ $f = 1MHz$	-	2637	-	μF
Output capacitance	C_{oss}		-	1250	-	
Reverse transfer capacitance	C_{rss}		-	17	-	
Turn-on delay time	$t_{d(on)}$	$V_{DD} = 380V, I_D = 10A$	-	25	-	ns
Rise time	t_r	$R_G = 4.7\Omega, V_{GS}=10V$	-	35	-	

Turn-off delay time	$t_{d(off)}$		-	97	-	
Fall time	t_f		-	12	-	
Gate charge characteristics						
Gate to source charge	Q_{gs}	$V_{DD}=480\text{ V}, I_D=10\text{ A},$ $V_{GS}=0\text{ to }10\text{ V}$	-	10.3	-	nC
Gate to drain charge	Q_{gd}		-	13.7	-	
Gate charge total	Q_g		-	39	-	
Gate plateau voltage	$V_{plateau}$		-	5.5	-	V
Reverse diode characteristics						
Diode forward voltage	V_{SD}	$V_{GS}=0\text{ V}, I_F=10\text{ A}$	-	-	1.2	V
Reverse recovery time	t_{rr}	$V_R=50\text{ V}, I_F=20\text{ A},$ $di_F/dt=100\text{ A}/\mu\text{s}$	-	171	-	ns
Reverse recovery charge	Q_{rr}		-	1.5	-	μC
Peak reverse recovery current	I_{rrm}		-	16	-	A

Notes:

- Limited by maximum junction temperature, maximum duty cycle is 0.75.
- $I_{AS} = 5\text{ A}$, $V_{DD} = 60\text{ V}$, Starting $T_j = 25^\circ\text{C}$.
- Repetitive Rating: Pulse width limited by maximum junction temperature.

Electrical Characteristics Diagrams

Figure 1. On-Region Characteristics

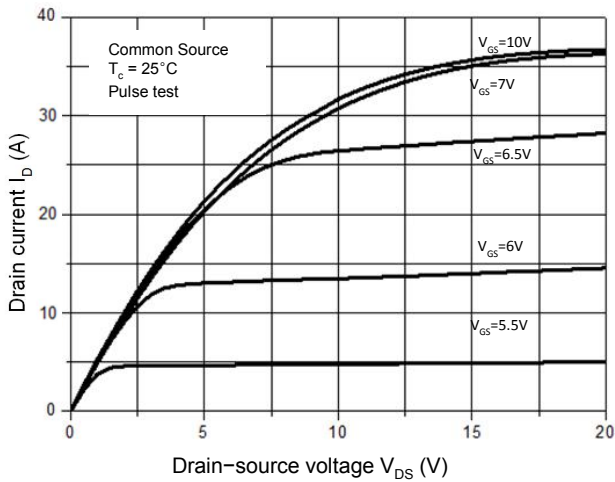

Figure 3. On-Resistance Variation vs. Drain Current

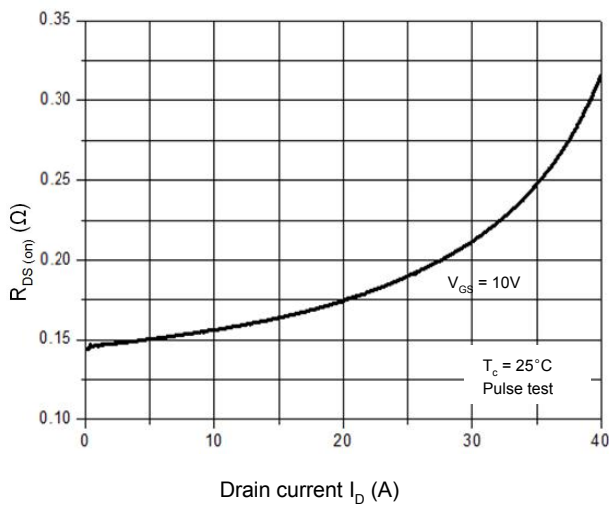

Figure 5. Breakdown Voltage vs. Temperature

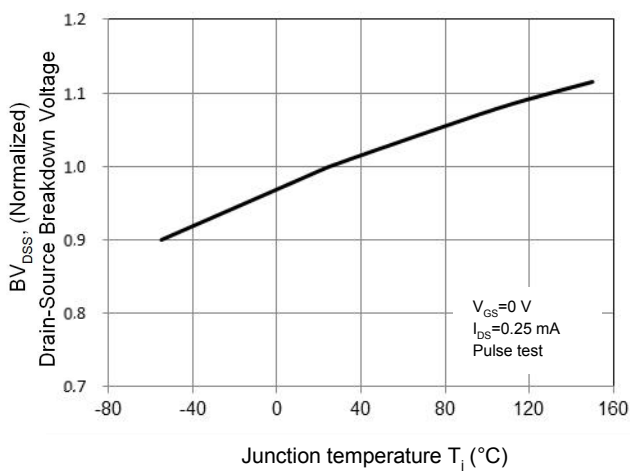

Figure 2. Transfer Characteristics

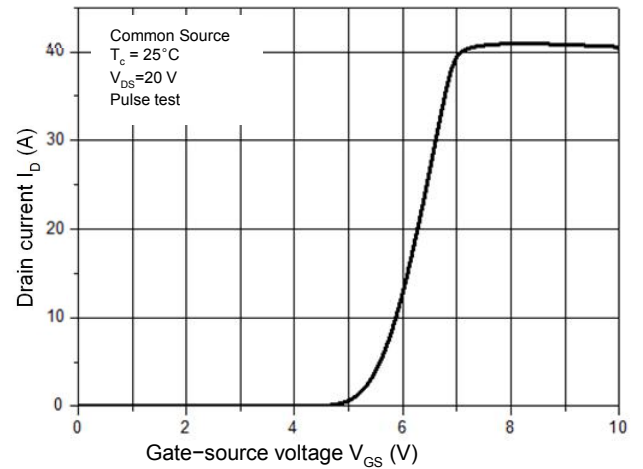

Figure 4. Threshold Voltage vs. Temperature

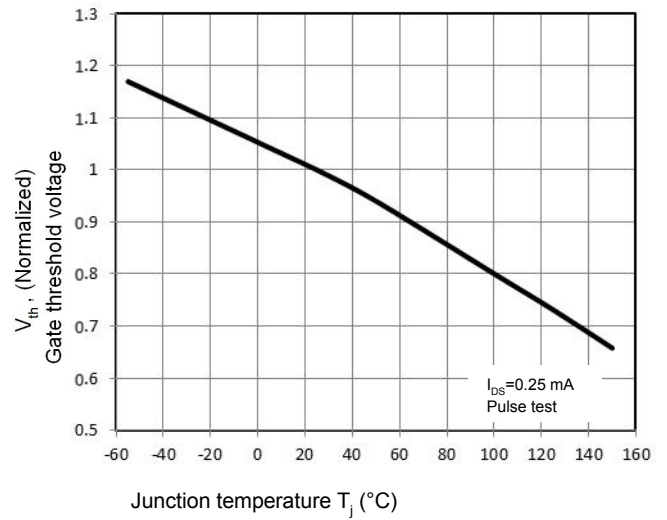

Figure 6. On-Resistance vs. Temperature

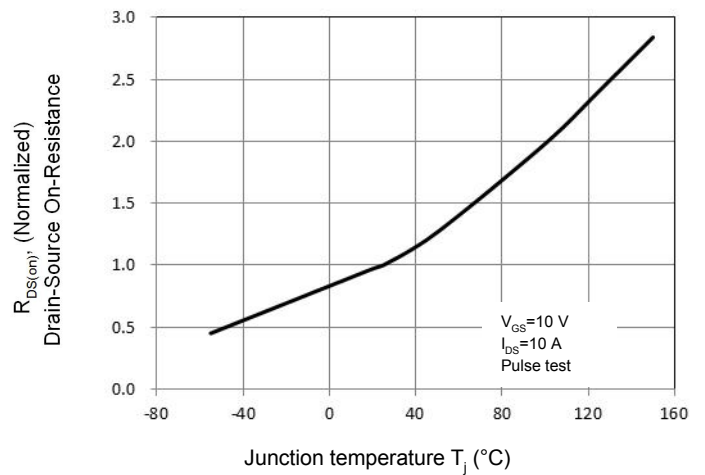

Figure 7. Capacitance Characteristics

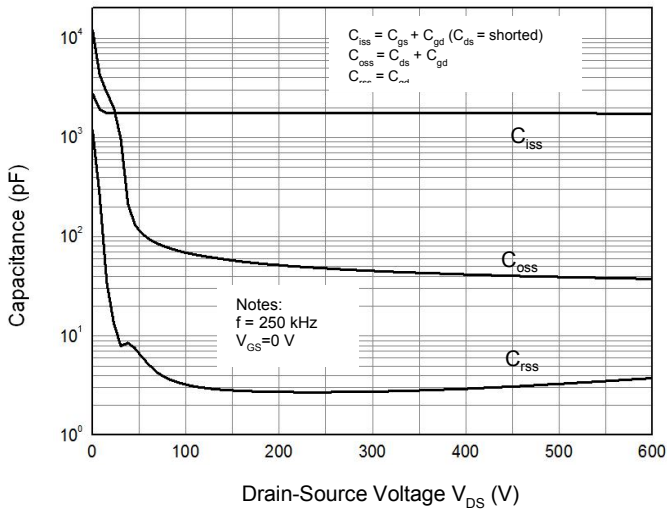

Figure 8. Gate Charge Characterist

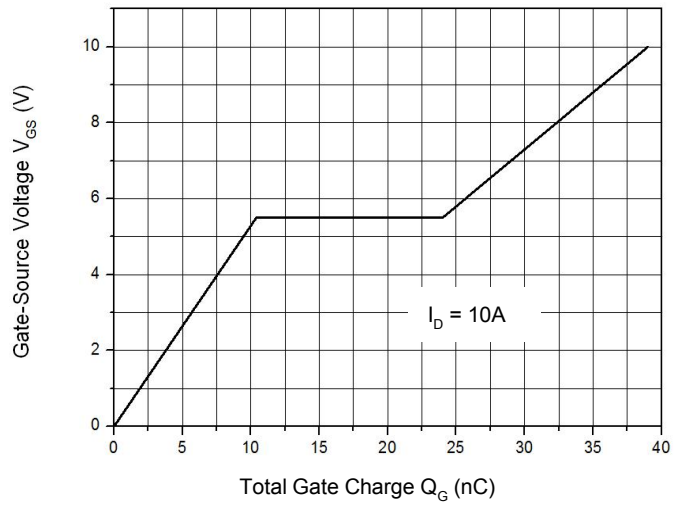

Figure 9.1 Maximum Safe Operating Area
TO-247/TO-263/TO-220/TO-262

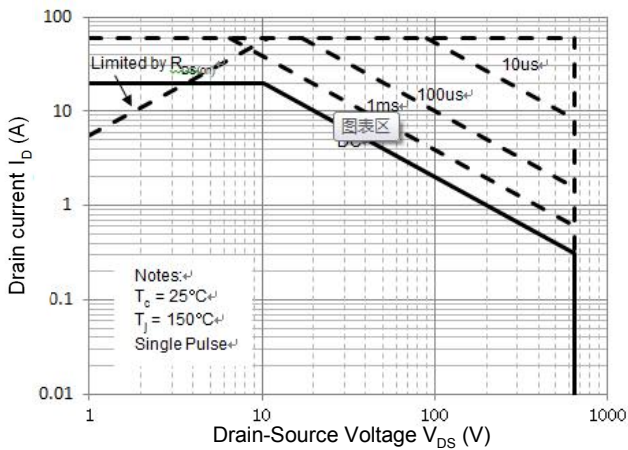

Figure 9.2 Maximum Safe Operating Area
TO-220MF

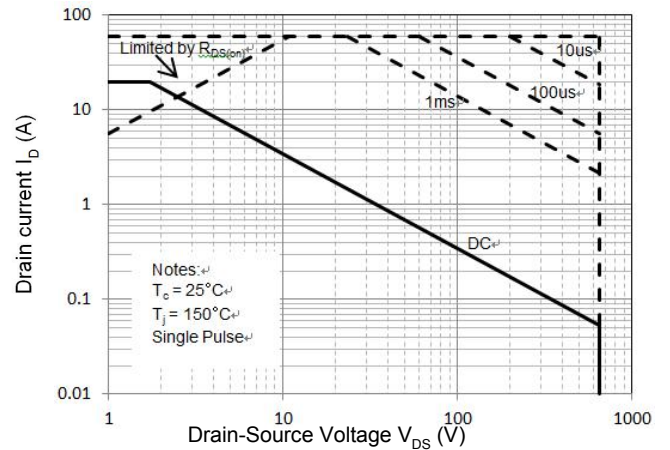

Figure 10.1 Power Dissipation vs. Temperature
O-247/TO-263/TO-220/TO-262

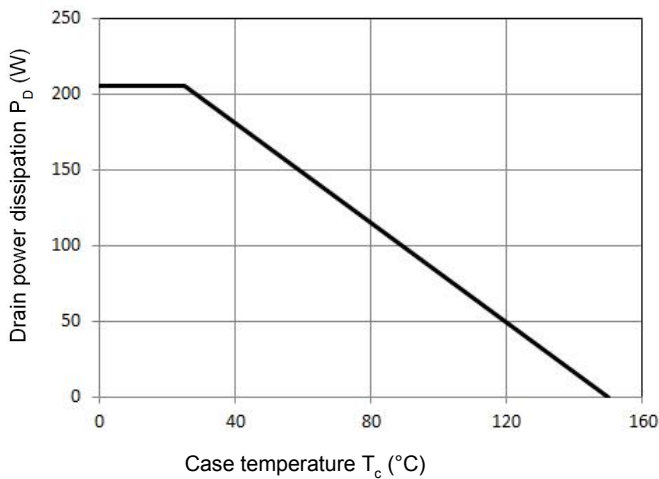

Figure 10.2 Power Dissipation vs. Temperature
TO-220MF

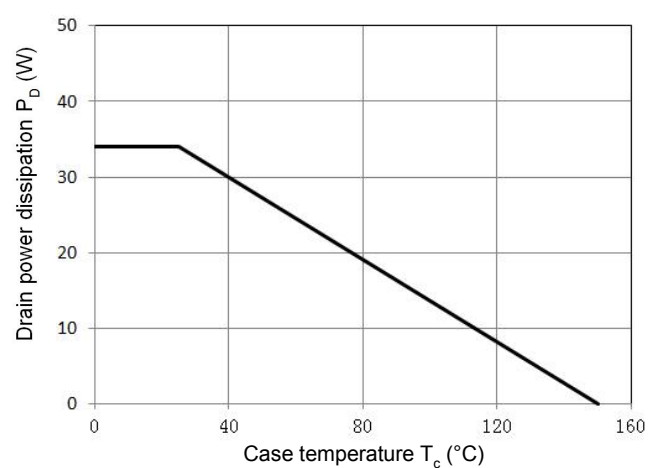

Figure 11.1 Transient Thermal Response Curve
 TO-247/TO-263/TO-220/TO-262

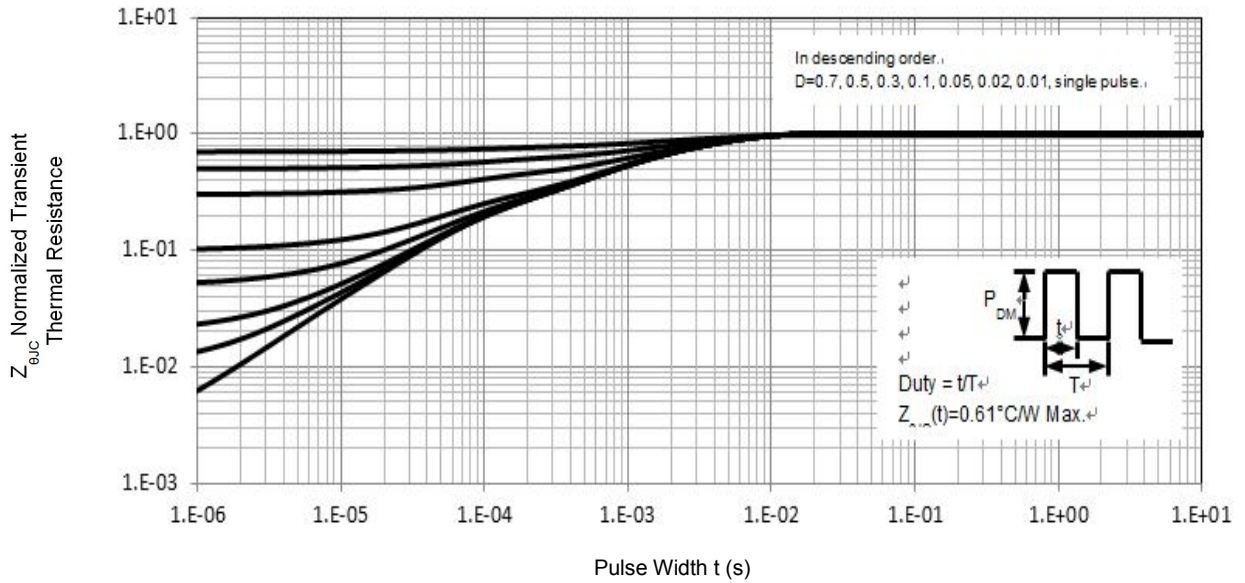
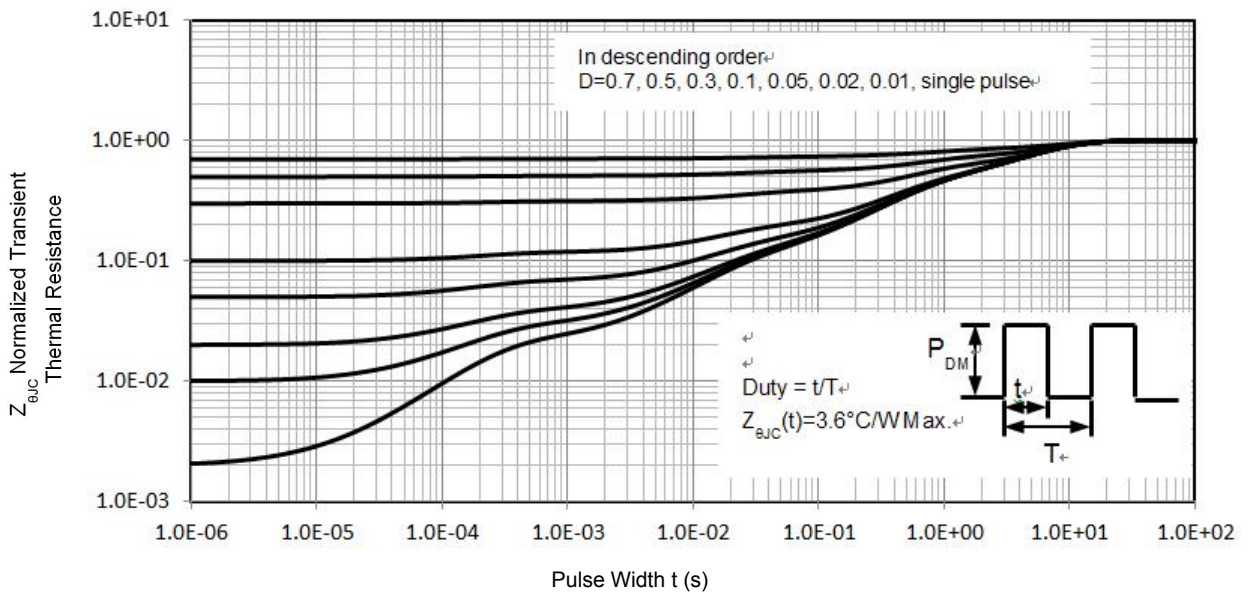
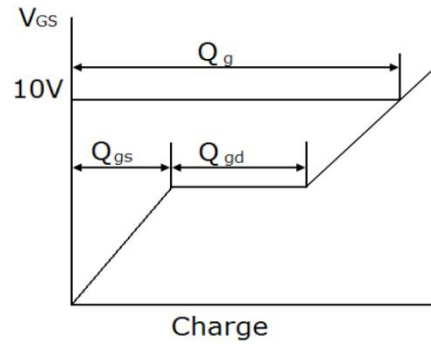
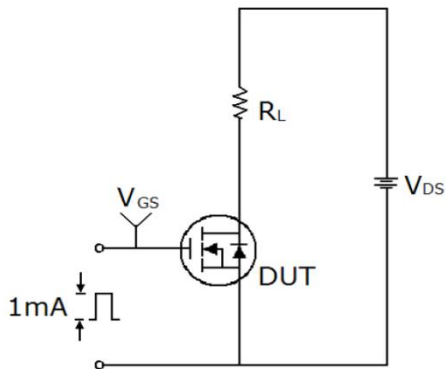

Figure 11.2 Transient Thermal Response Curve
 TO-220MF



Gate Charge Test Circuit & Waveform



Switching Test Circuit & Waveforms

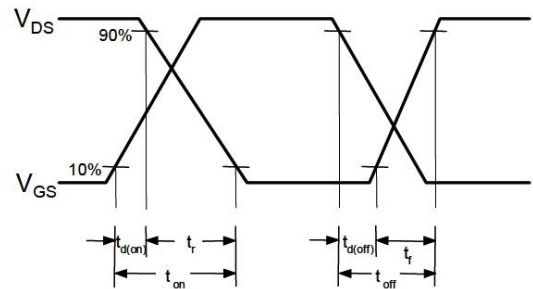
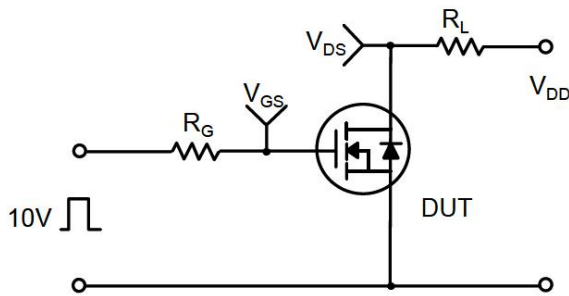

Unclamped Inductive Switching Test Circuit & Waveforms

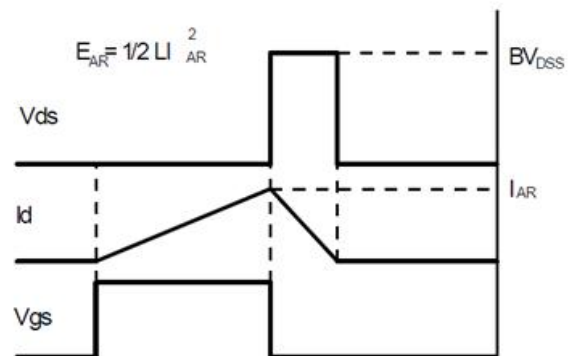
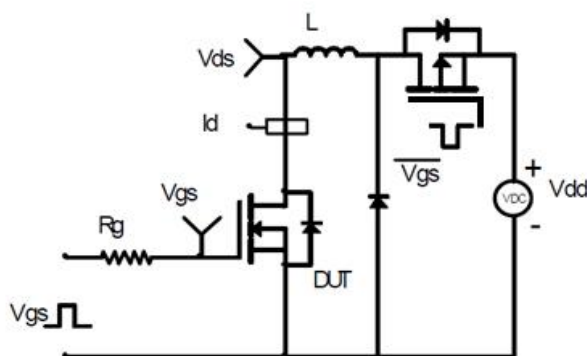

Mechanical Dimensions for TO-247

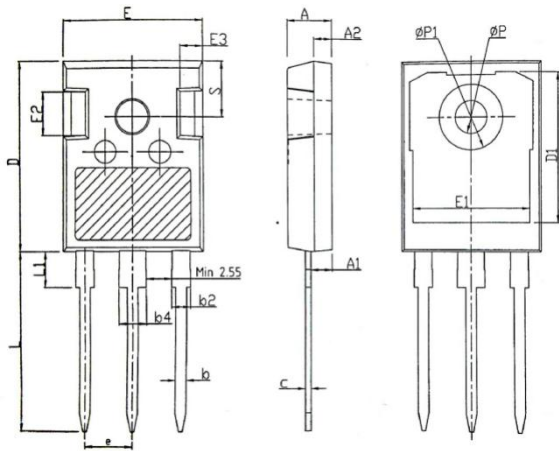

SYMBOL	mm		
	MIN	NOM	MAX
A	4.80	5.00	5.20
A1	2.21	2.41	2.59
A2	1.85	2.00	2.15
b	1.11	1.21	1.36
b2	1.91	2.01	2.21
b4	2.91	3.01	3.21
c	0.51	0.61	0.75
D	20.80	21.00	21.30
D1	16.25	16.55	16.85
E	15.50	15.80	16.10
E1	13.00	13.30	13.60
E2	4.80	5.00	5.20
E3	2.30	2.50	2.70
e	5.44BSC		
L	19.82	19.92	20.22
L1	—	—	4.30
ØP	3.40	3.60	3.80
ØP1	—	—	7.30
S	6.15BSC		

TO-247 Part Marking Information

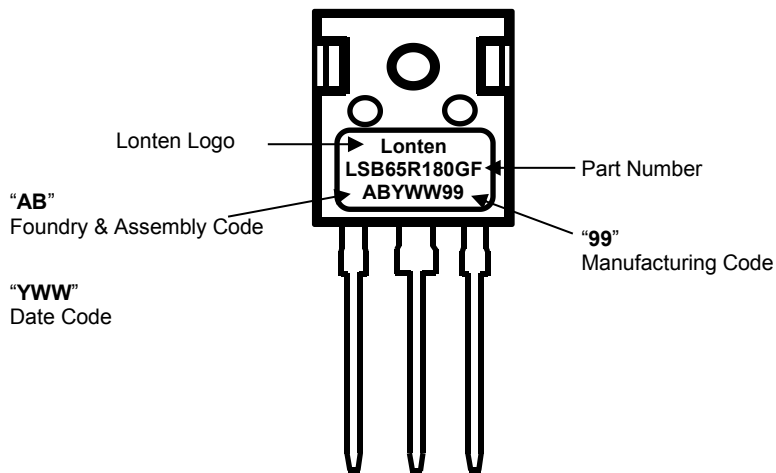

Mechanical Dimensions for TO-220MF

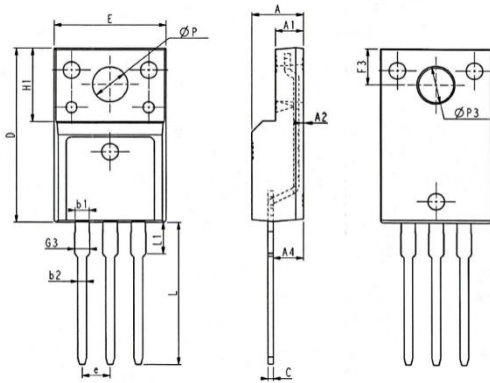

SYMBOL	COMMON DIMENSIONS					
	MM			INCH		
	MIN	NOM	MAX	MIN	NOM	MAX
E	9.96	10.16	10.36	0.392	0.400	0.408
A	4.50	4.70	4.90	0.177	0.185	0.193
A1	2.34	2.54	2.74	0.092	0.100	0.108
A2	0.30	0.45	0.60	0.012	0.020	0.024
A4	2.65	2.76	2.96	0.104	0.109	0.117
C	0.40	0.50	0.65	0.016	0.020	0.026
D	15.57	15.87	16.17	0.613	0.625	0.637
H1	6.70REF			0.264REF		
e	2.54BSC			0.1BSC		
ØP	3.03	3.18	3.38	0.119	0.125	0.133
L	12.68	12.98	13.28	0.499	0.511	0.523
L1	2.88	3.03	3.18	0.113	0.119	0.125
ØP3	3.15REF			0.124REF		
F3	3.15	3.30	3.45	0.124	0.130	0.136
G3	1.25	1.35	1.55	0.049	0.053	0.061
b1	1.18	1.28	1.43	0.046	0.050	0.056
b2	0.70	0.80	0.95	0.028	0.031	0.037

TO-220MF Part Marking Information

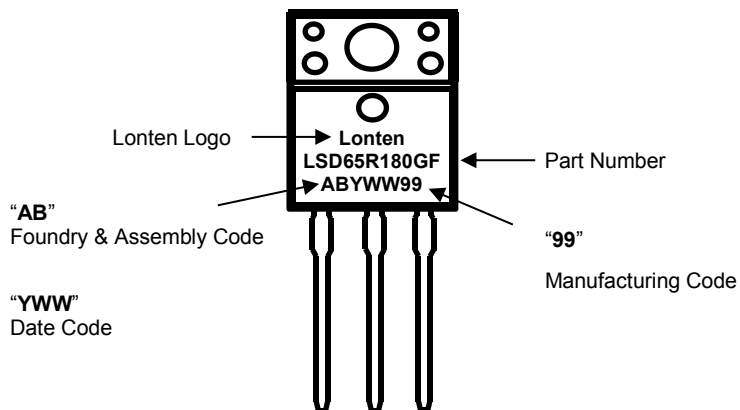

Mechanical Dimensions for TO-220

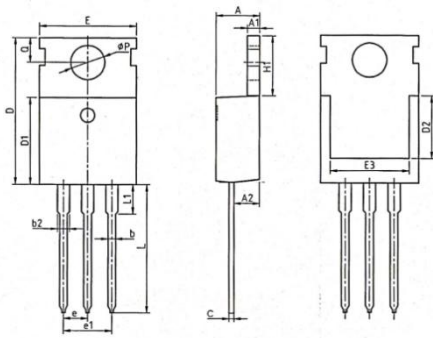

COMMON DIMENSIONS						
SYMBOL	MM			INCH		
	MIN	NOM	MAX	MIN	NOM	MAX
A	4.37	4.57	4.70	0.172	0.180	0.185
A1	1.25	1.30	1.40	0.049	0.051	0.055
A2	2.20	2.40	2.60	0.087	0.094	0.102
b	0.70	0.80	0.95	0.028	0.031	0.037
b2	1.17	1.27	1.47	0.046	0.050	0.058
c	0.45	0.50	0.60	0.018	0.020	0.024
D	15.10	15.60	16.10	0.594	0.614	0.634
D1	8.80	9.10	9.40	0.346	0.358	0.370
D2	5.50	—	—	0.217	—	—
E	9.70	10.00	10.30	0.382	0.394	0.406
E3	7.00	—	—	0.276	—	—
e	2.54BSC			0.1BSC		
e1	5.08BSC			0.2BSC		
H1	6.25	6.50	6.85	0.246	0.256	0.270
L	12.75	13.50	13.80	0.502	0.531	0.543
L1	—	3.10	3.40	—	0.122	0.134
Øp	3.40	3.60	3.80	0.134	0.142	0.150
Q	2.60	2.80	3.00	0.102	0.110	0.118

TO-220 Part Marking Information

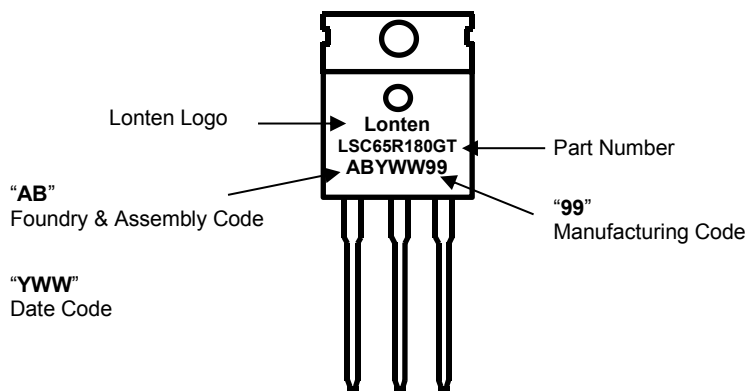

Mechanical Dimensions for TO-263

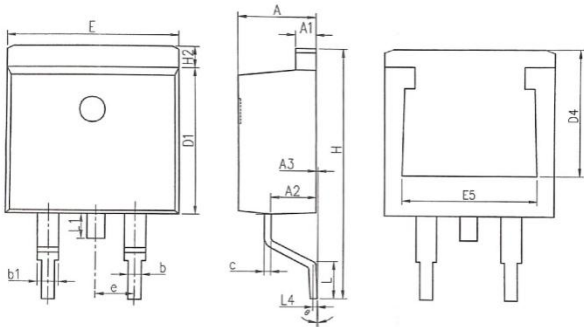

COMMON DIMENSIONS						
SYMBOL	MM			INCH		
	MIN	NOM	MAX	MIN	NOM	MAX
A	4.37	4.57	4.77	0.172	0.180	0.188
A1	1.22	1.27	1.42	0.048	0.050	0.056
A2	2.49	2.89	2.89	0.098	0.114	0.114
A3	0.00	0.13	0.25	0.000	0.005	0.010
b	0.70	0.81	0.96	0.028	0.032	0.034
b1	1.17	1.27	1.47	0.046	0.050	0.058
c	0.30	0.38	0.53	0.012	0.015	0.021
D1	8.50	8.70	8.90	0.335	0.343	0.350
D4	6.60	—	—	0.260	—	—
E	9.86	10.16	10.36	0.389	0.400	0.408
E5	7.06	—	—	0.278	—	—
e	2.54 BSC			0.100 BSC		
H	14.70	15.10	15.50	0.579	0.594	0.610
H2	1.07	1.27	1.47	0.042	0.050	0.058
L	2.00	2.30	2.60	0.079	0.091	0.102
L1	1.40	1.55	1.70	0.055	0.061	0.067
L4	0.25 BSC			0.010 BSC		
θ	0°	5°	9°	0°	0.197°	0.354°

TO-263 Part Marking Information

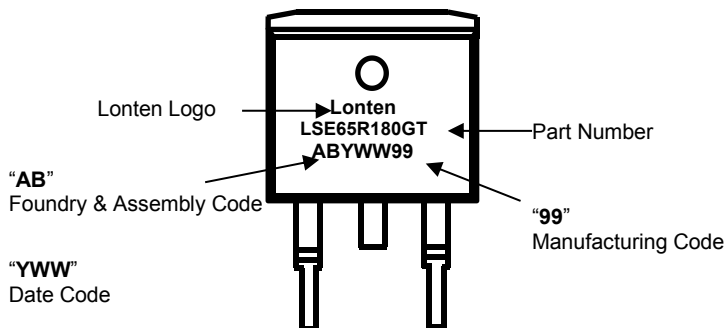

Mechanical Dimensions for TO-262

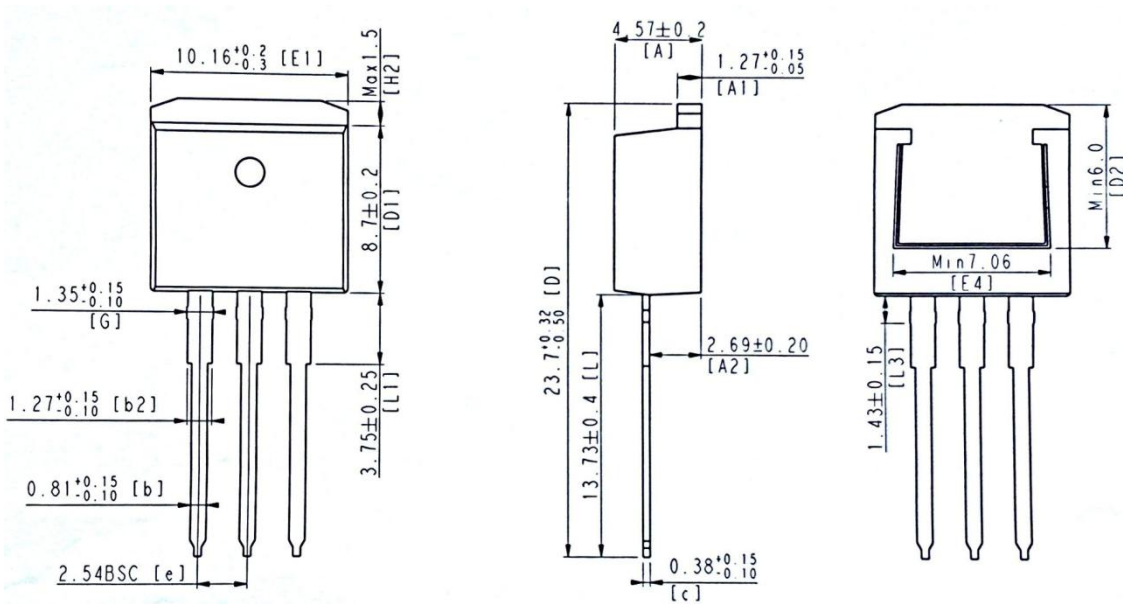

TO-262 Part Marking Information

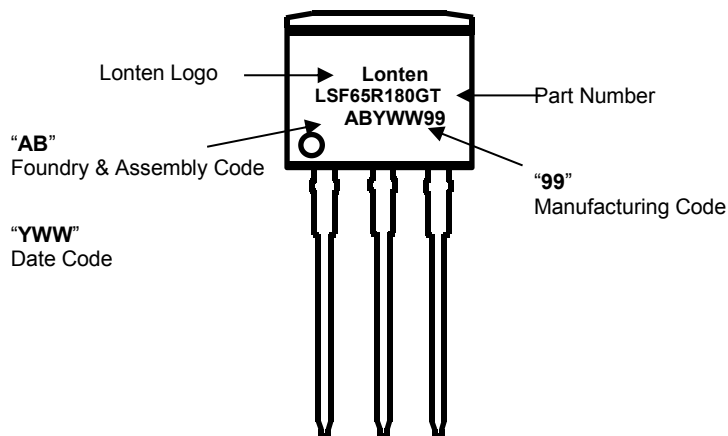

Disclaimer

The content specified herein is for the purpose of introducing LONTEN's products (hereinafter "Products"). The information given in this document shall in no event be regarded as a guarantee of conditions or characteristics. Examples of application circuits, circuit constants and any other information contained herein illustrate the standard usage and operations of the Products. The peripheral conditions must be taken into account when designing circuits for mass production.

LONTEN does not assume any liability for infringement of patents, copyrights, or other intellectual property rights of third parties by or arising from the use of the Products or technical information described in this document.

The Products are not designed or manufactured to be used with any equipment, device or system which requires an extremely high level of reliability the failure or malfunction of which may result in a direct threat to human life or create a risk of human injury (such as a medical instrument, transportation equipment, aerospace machinery, nuclear-reactor controller, fuel-controller or other safety device). LONTEN shall bear no responsibility in any way for use of any of the Products for the above special purposes.

Although LONTEN endeavors to improve the quality and reliability of its products, semiconductor products have specific characteristics such as the occurrence of failure at a certain rate and malfunctions under certain use conditions. Please be sure to implement safety measures to guard them against the possibility of physical injury, and injury or damage caused by fire in the event of the failure of a LONTEN product.

The content specified herein is subject to change for improvement without notice. When using a LONTEN product, be sure to obtain the latest specifications.