

RevNo	Revision note	Date	Signature
△			

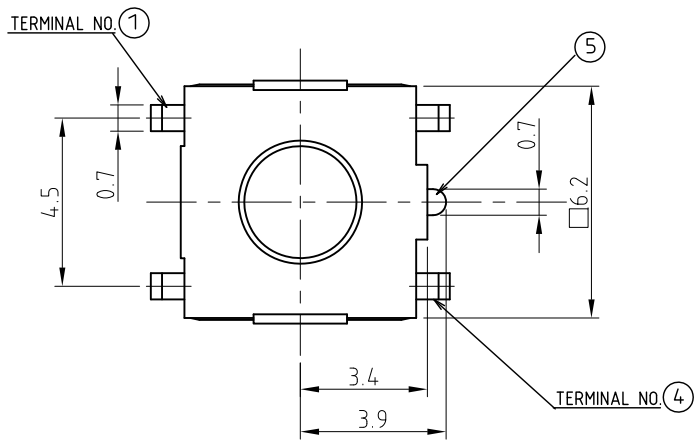

CIRCUIT DIAGRAM

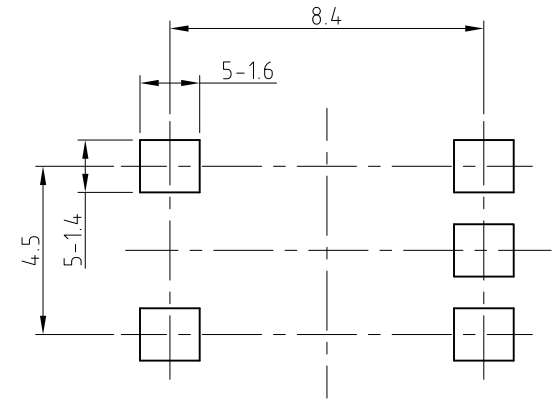
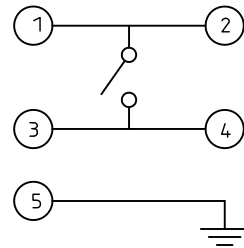

P.C.B LAND DIMENSION

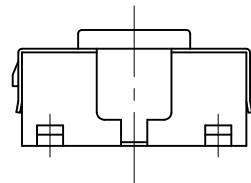
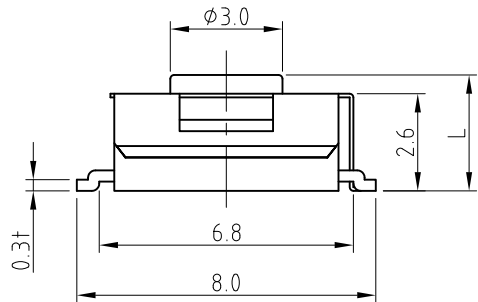

NOTE.

1. TRAVEL : 0.25 +0.2/-0.1
2. CONTACT RESISTANCE : 50 mΩMAX
3. GENERAL TOLERANCE : ±0.3
4. MANUFACTURING SPECIFICATION
WOULD BE ACCORDANCE WITH JT0115LF

MODEL NAME	CODE NO.	L	STEM COLOR	O/FORCE	REMARKS
JTP1161A		4.3	BLACK	160 ±50gf	
JTP1161		3.1	BLACK	160 ±50gf	

Designed by			
Checked by			
Approved by	Unit	Scale	Date
Item	TACTILE SWITCH	mm	N/S
Model	JTP 1161 SERIES	Tool	Sheet
		Au	1/1
		Drawing name	Rev.
		ASSEMBLY	1

	SPECIFICATION	PAGE
	TACT SWITCH	1 / 4

1. GENERAL

1.1 Application : This specification is applied to low current circuit tactile switch for electronic equipment.

1.2 Operating temperature range : -20 ~ 70°C, 45 ~ 85% RH

1.3 Storage temperature range : -30 ~ 80°C. However, 96 hours maximum for continuous storage over a range -20 ~ -30°C and a range 70 ~ 80°C.

1.4 Test conditions : The standard test conditions shall be 5 ~ 35°C in temperature, 45 ~ 85% RH and 860 ~ 1060mbar in atmospheric pressure. Should any doubt arise in judgement, tests shall be conducted at 20±2°C, 65±5% RH and 860 ~ 1060mbar.

2. RATED VOLTAGE AND CURRENT.

DC 12V 50mA

3. ELECTRICAL PERFORMANCE

	PROPERTY	TEST CONDITIONS	PERFORMANCE
3.1	Contact arrangement		* 1 pole, 1 throw.
3.2	Contact resistance	Measured at DC 5V 10mA or by ohmmeter allowing a small current at 1kHz with 150% of actuating force.	* As per individual manufactured drawing.
3.3	Insulation resistance	DC 100V is applied between terminals and between terminals and cover for 1minute ±5seconds.	* greater than 100MΩ.
3.4	Dielectric strength	AC 250V (50 ~ 60Hz)is applied between terminals and between terminals and cover for 1 minute.	* No insulation defect shall be observed.
3.5	Bounce	Measured by lightly striking the center of the stem at a rate of 3 operations/sec..	* less than 5 msec.

						APPD	CHKD	DSGN	TITLE
									DOCUMENT NO.
									JT 0115LF
ZONE	SYMB	DATE	APPD	CHKD	DSGD				

	SPECIFICATION	PAGE
	TACT SWITCH	2 / 4

4. MECHANICAL PERFORMANCE

	PROPERTY	TEST CONDITIONS	PERFORMANCE
4.1	Actuating force	A gradually increasing load is applied to the center of the stem.	* As per individual manufactured drawing.
4.2	Return force	After actuating, the load is gradually decreased until the stem returns to its free position.	* 160gf, 260gf : greater than 50gf. * 100gf, 130gf : greater than 30gf.
4.3	Stop strength	A static force of 3Kgf shall be applied to the direction of operation for 3 seconds.	* Shall be free from mechanical and electrical abnormalities.
4.4	Stem withdrawal force	A static load of 500gf is applied to the direction of pulling for 3 seconds.	* Shall be free from mechanical and electrical degradation.
4.5	Travel		* As per individual manufactured drawing.
4.6	Arrangement of action		* Tactile feed-back.

5. DURABILITY

	PROPERTY	TEST CONDITIONS	PERFORMANCE
5.1	Operating life	100,000cycles operation with a load of 150% of Actuating force a rate of 2 cycles/sec. With a resistive load supplying DC 12V 50mA.	* Contact resistance : 500mΩ max. * Bounce : 20msec max. * Actuating force : within ±30% of the initial value.
5.2	Shock resistance	An impact load of 30g is applied according to the method 205 , MIL-STD 202.	* The requirement in Item 3 and 4 shall be met.
5.3	Vibration resistance	The test is conducted according to the method 201, MIL-STD 202.	* The requirement in Item 3 and 4 shall be satisfied without any degradation in both appearance and actuation.

						APPD	CHKD	DSGN	TITLE
									DOCUMENT NO.
									JT 0115LF
ZONE	SYMB	DATE	APPD	CHKD	DSGD				

	SPECIFICATION	PAGE
	TACT SWITCH	3 / 4

6. WEATHER PROOF

	PROPERTY	TEST CONDITIONS	PERFORMANCE
6.1	Cold heat proof	After testing at -30°C for 96hours, the sample is allowed to stand under normal temperature and humidity conditions for 1hour and measurement is performed within 1hour after that. Water drops should be wiped off.	* The requirement in item 3 and 4 shall be met.
6.2	Dry heat proof	After testing at 85°C for 96hours, the sample is allowed to stand under normal temperature for 1hour and measurement is performed within 1hour after that.	
6.3	Damp heat proof	After test at $60\pm 2^{\circ}\text{C}$ and 90 ~ 95% in relative humidity for 96hours, the sample is allowed to stand under normal temperature and humidity conditions for 1hour, and measurement is performed within 1hour after that. Water drops should be wiped off.	<ul style="list-style-type: none"> * Insulation resistance : $10\text{M}\Omega$ minimum. * Dielectric strength : same as item 3.4. * Contact resistance : same as item 3.2.
6.4	Thermal cycling	<p style="text-align: center;">; After the test conducted under 5 cycles the sample is allowed to stand under normal temperature and humidity conditions for 1hour, and the measurement is performed within 1hour.</p>	* The requirement in item 3 and 4 shall be met.

						APPD	CHKD	DSGN	TITLE
									DOCUMENT NO.
									JT 0115LF
ZONE	SYMB	DATE	APPD	CHKD	DSGD				

	SPECIFICATION	PAGE
	TACT SWITCH	4 / 4

7. REFLOW SOLDERING

7.1 Reflow soldering conditions

- 1) Preheat ----- 150°C ~ 200°C, 120 ±20 (sec)
- 2) Peak temperature --- 260°C max. 10 (sec)
- 3) Soldering area temperature ----- 217°C, 90 ~ 120 (sec)

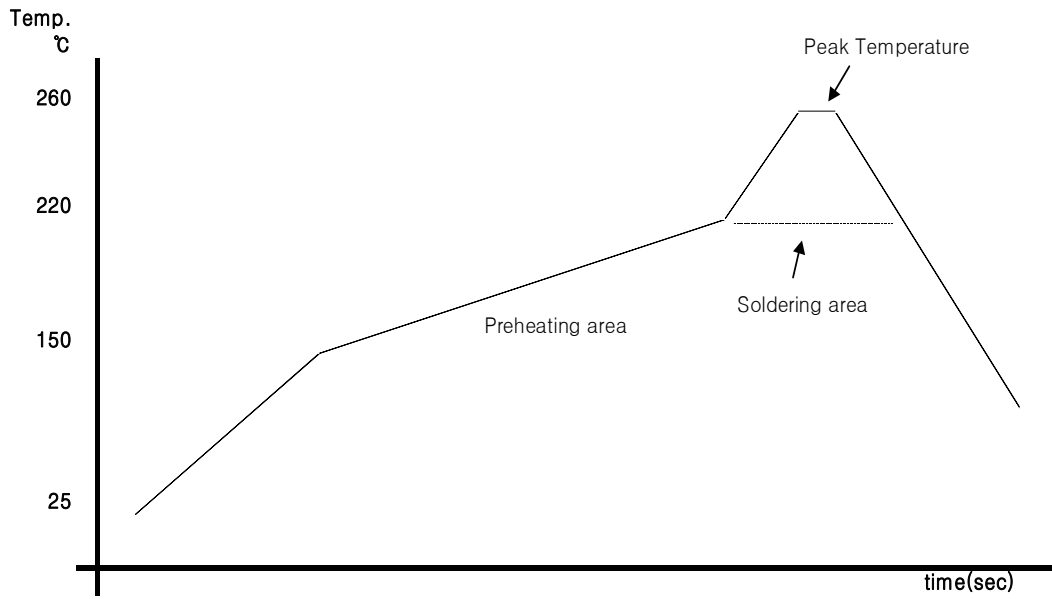

< Temperature profile >

						APPD	CHKD	DSGN	TITLE
									DOCUMENT NO.
									JT 0115LF
ZONE	SYMB	DATE	APPD	CHKD	DSGD				