

K-no.: 26019

25 A Current Sensor for 5V- Supply Voltage

 For electronic current measurement:
 DC, AC, pulsed, mixed ..., with a galvanic
 isolation between primary circuit
 (high power) and secondary circuit
 (electronic circuit)

Date: 17.08.2017

Customer: Standard type

Customers Part no.:

Page 1 of 4

Description

- Closed loop (compensation)
- Current Sensor with magnetic field probe
- Printed circuit board mounting
- Casing and materials UL-listed

Characteristics

- Excellent accuracy
- Very low offset current
- Very low temperature dependency and offset current drift
- Very low hysteresis of offset current
- Short response time
- Wide frequency bandwidth
- Compact design
- Reduced offset ripple

Applications

Mainly used for stationary operation in industrial applications:

- AC variable speed drives and servo motor drives
- Static converters for DC motor drives
- Battery supplied applications
- Switched Mode Power Supplies (SMPS)
- Power Supplies for welding applications
- Uninterruptible Power Supplies (UPS)

Electrical data – Ratings

I_{PN}	Primary nominal r.m.s. current	25	A
V_{out}	Output voltage @ I_P	$V_{Ref} \pm (0.625 \cdot I_P / I_{PN})$	V
V_{out}	Output voltage @ $I_P=0, T_A=25^\circ\text{C}$	$V_{Ref} \pm 0.00135$	V
V_{Ref}	External Reference voltage range	0...4	V
	Internal Reference voltage	2.5 ± 0.005	V
K_N	Turns ratio	1...4 : 2000	

Accuracy – Dynamic performance data

		min.	typ.	max.	Unit
$I_{P,max}$	Max. measuring range	±85			
X	Accuracy @ $I_{PN}, T_A=25^\circ\text{C}$	0.7			%
ϵ_L	Linearity	0.1			%
$V_{out} - V_{Ref}$	Offset voltage @ $I_P=0, T_A=25^\circ\text{C}$	±1.35			mV
$\Delta V_o / V_{Ref} / \Delta T$	Temperature drift of V_{out} @ $I_P=0, V_{Ref}=2,5\text{V}, T_A=-40...85^\circ\text{C}$	1.4	10		ppm/°C
t_r	Response time @ 90% von I_{PN}	300			ns
$\Delta t (I_{P,max})$	Delay time at $di/dt = 100 \text{ A}/\mu\text{s}$	200			ns
f	Frequency bandwidth	DC...200			kHz

General data

		min.	typ.	max.	Unit
T_A	Ambient operating temperature	-40		+85	°C
T_S	Ambient storage temperature (acc to M3101)	-40		+105	°C
m	Mass		12		g
V_C	Supply voltage	4.75	5	5.25	V
I_C	Current consumption		15		mA

 Constructed and manufactured and tested in accordance with EN 61800-5-1 (Pin 1 – 4 to Pin 5 – 12)
 Reinforced insulation, Insulation material group 1, Pollution degree 2

S_{clear}	Clearance (component without solder pad)	9.6			mm
S_{creep}	Creepage (component without solder pad)	10.6			mm
V_{sys}	System voltage overvoltage category 3	RMS		600	V
V_{work}	Working voltage	RMS		1060	V
U_{PD}	Rated discharge voltage	peak value		1320	V

 Note: According UL 508: Max. potential difference = 600 V_A

Date	Name	Issue	Amendment
17.08.17	DJ	83	Page 3, Type test M3064 accurately defined. Minor change.
21.02.17	BZ	83	Page A1, M-sheet M3101 added (storage temperature). Minor change

Hrsg.: R&D-PD-NPI editor	Bearb: Le designer	MC-PM: Ga. check	freig.: BEF released
-----------------------------	-----------------------	---------------------	-------------------------

K-no.: 26019

25 A Current Sensor for 5V- Supply Voltage

For electronic current measurement:
DC, AC, pulsed, mixed ..., with a galvanic
isolation between primary circuit
(high power) and secondary circuit
(electronic circuit)

Date: 17.08.2017

Customer: Standard type

Customers Part no.:

Page 2 of 4

Mechanical outline (mm):

General tolerances DIN ISO 2768-c

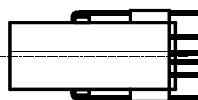
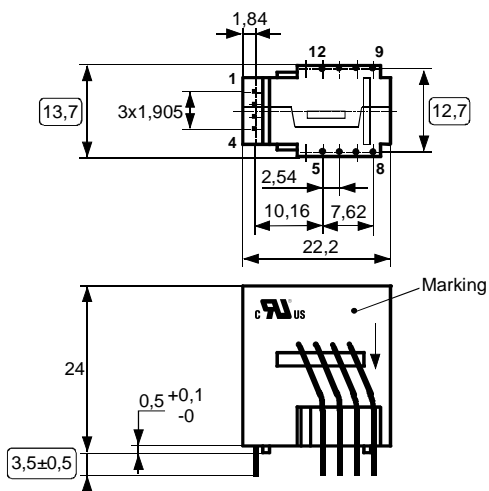

Connections:

1...4: 0,46*0,46 mm
5..12: Ø 1 mm

Marking:

VAC UL-sign
4646-X761-83
F DC

○ test dimension

Tolerances grid distance ±0,25mm

DC= Date Code
F = Factory

Explanation:

DC = Date Code [YWW]

Schematic diagram

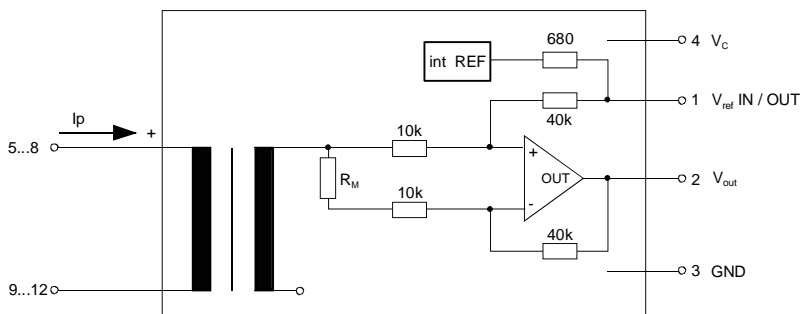

Possibilities of wiring (@ TA = 85°C)

primary windings	primary current RMS	primary current maximal	output voltage RMS	turns ratio	primary resistance	wiring
N_P	I_P [A]	$\hat{I}_{P,max}$ [A]	$V_{out}(I_P)$ [V]	K_N	R_P [mΩ]	
1	25	±85	2.5±0.625	1:2000	0.25	
2	12	±42	2.5±0.600	2:2000	1.0	
4	6	±21	2.5±0.600	4:2000	4	

Hrsg.: R&D-PD-NPI
editor

Bearb.: Le
designer

MC-PM: Ga.
check

freig.: BEF
released

K-no.: 26019
25 A Current Sensor for 5V- Supply Voltage

 For electronic current measurement:
 DC, AC, pulsed, mixed ..., with a galvanic
 isolation between primary circuit
 (high power) and secondary circuit
 (electronic circuit)

Date: 17.08.2017
Customer: Standard type
Customers Part no.:
Page 3 of 4
Electrical Data

		min.	typ.	max.	Unit
V_{Ctot}	Maximum supply voltage (without function)			7	V
I_C	Supply Current with primary current		15mA + $I_p \cdot K_N + V_{out}/R_L$		mA
$I_{out,SC}$	Short circuit output current		±20		mA
R_P	Resistance / primary winding @ $T_A=25^\circ C$		1		mΩ
R_S	Secondary coil resistance @ $T_A=85^\circ C$			67	Ω
$R_{i,Ref}$	Internal resistance of Reference input		670		Ω
$R_{i,(V_{out})}$	Output resistance of V_{out}			1	Ω
R_L	External recommended resistance of V_{out}	1			kΩ
C_L	External recommended capacitance of V_{out}			500	pF
$\Delta X_{Ti} / \Delta T$	Temperature drift of X @ $T_A = -40 \dots +85^\circ C$			40	ppm/K
$\Delta V_0 = \Delta(V_{out} - V_{Ref})$	Sum of any offset drift including:		2	6	mV
V_{0t}	Longtermdrift of V_0		1		mV
V_{0T}	Temperature drift von V_0 @ $T_A = -40 \dots +85^\circ C$		1		mV
V_{0H}	Hysteresis of V_{out} @ $I_p=0$ (after an overload of $10 \times I_{PN}$)			2	mV
V_{0H}	Hysteresis of V_{out} @ $I_p=0$ (after an overload of 66 A)			0.5	mV
$\Delta V_0 / \Delta V_C$	Supply voltage rejection ratio			1	mV/V
V_{oss}	Offsetripple (with 1 MHz- filter first order)			30	mV
V_{oss}	Offsetripple (with 100 kHz- filter first order)		3	6	mV
V_{oss}	Offsetripple (with 20 kHz- filter first order)		0.8	1.5	mV
C_k	Maximum possible coupling capacity (primary – secondary) Mechanical stress according to M3209/3 Settings: 10 – 2000 Hz, 1 min/Octave, 2 hours		5	10	pF

Inspection (Measurement after temperature balance of the samples at room temperature; SC = significant characteristic)

$V_{out} (I_p=I_{PN})$ (V)	M3011/6:	Output voltage vs. external reference ($I_p=25A$, 40-80Hz)	625±0,7%	mV (SC)
$V_{out}-V_{Ref} (I_p=0)$ (V)	M3226:	Offset voltage	± 1.35	mV
V_d (V)	M3014:	Test voltage, rms, 1 s pin 1 – 4 vs. pin 5 – 12	1.8	kV
V_e (AQL 1/S4)		Partial discharge voltage acc.M3024 (RMS) with V_{vor} (RMS)	1400 1750	V V

Type Testing (Pin 1 - 4 to Pin 5 - 12)

V_W	HV transient test according to M3064 (1.2 μs / 50 μs-wave form) 5 pulse → polarity +, 5 pulse → polarit -		8	kV
V_d	Testing voltage to M3014	(5 s)	3.6	kV
V_e	Partial discharge voltage acc.M3024 (RMS) with V_{vor} (RMS)		1400 1750	V V

Applicable documents

Current direction: A positive output current appears at point I_S , by primary current in direction of the arrow.
 Housing and bobbin material UL-listed: Flammability class 94V-0.
 Enclosures according to IEC529: IP50.
 Operating temperature of the current sensor and the primary conductor must not exceed 105°C
 Further standards UL 508 ; file E317483, category NMTR2 / NMTR8

 Hrsg.: R&D-PD-NPI
 editor

 Bearb.: Le
 designer

 MC-PM: Ga.
 check

 freig.: BEF
 released

K-no.: 26019

25 A Current Sensor for 5V- Supply Voltage

 For electronic current measurement:
 DC, AC, pulsed, mixed ..., with a galvanic
 isolation between primary circuit
 (high power) and secondary circuit
 (electronic circuit)

Date: 17.08.2017

Customer: Standard type

Customers Part no.:

Page 4 of 4

Explanation of several of the terms used in the tablets (in alphabetical order)

t_r : Response time (describe the dynamic performance for the specified measurement range), measured as delay time at $I_P = 0,9 \cdot I_{PN}$ between a rectangular current and the output voltage $V_{out}(I_P)$

$\Delta t(I_{Pmax})$: Delay time (describe the dynamic performance for the rapid current pulse rate e.g short circuit current) measured between I_{Pmax} and the output voltage $V_{out}(I_{Pmax})$ with a primary current rise of $di_P/dt \geq 100 A/\mu s$.

V_o : Offset voltage between V_{out} and the rated reference voltage of $V_{ref} = 2,5V$.
 $V_o = V_{out}(0) - 2,5V$

U_{PD} Rated discharge voltage (recurring peak voltage separated by the insulation) proved with a sinusoidal voltage V_e
 $U_{PD} = \sqrt{2} \cdot V_e / 1,5$

V_{vor} Defined voltage is the RMS value of a sinusoidal voltage with peak value of $1,875 \cdot U_{PD}$ required for partial discharge test in IEC 61800-5-1
 $V_{vor} = 1,875 \cdot U_{PD} / \sqrt{2}$

V_{sys} System voltage RMS value of rated voltage according to IEC 61800-5-1

V_{work} Working voltage voltage according to IEC 61800-5-1 which occurs by design in a circuit or across insulation

V_{OH} : Zero variation of V_o after overloading with a DC of tenfold the rated value

V_{ot} : Long term drift of V_o after 100 temperature cycles in the range -40 bis 85 °C.

X : Permissible measurement error in the final inspection at RT, defined by

$$X = 100 \cdot \left| \frac{V_{out}(I_{PN}) - V_{out}(0)}{0,625V} - 1 \right| \%$$

$X_{ges}(I_{PN})$: Permissible measurement error including any drifts over the temperature range by the current measurement I_{PN}

$$X_{ges} = 100 \cdot \left| \frac{V_{out}(I_{PN}) - 2,5V}{0,625V} - 1 \right| \% \quad \text{or} \quad X_{ges} = 100 \cdot \left| \frac{V_{out}(I_{PN}) - V_{ref}}{0,625V} - 1 \right| \%$$

ϵ_L : Linearity fault defined by
$$\epsilon_L = 100 \cdot \left| \frac{I_P}{I_{PN}} - \frac{V_{out}(I_P) - V_{out}(0)}{V_{out}(I_{PN}) - V_{out}(0)} \right| \%$$

 Hrsg.: R&D-PD-NPI
 editor

 Bearb.: Le
 designer

 MC-PM: Ga.
 check

 freig.: BEF
 released