

(RoHS)

# 产 品 规 格 书

## SPECIFICATION FOR APPROVAL

客户名称:  
Customer Name: \_\_\_\_\_

产品名称:  
Product Name: 贴片石英晶体谐振器

产品型号:  
Product Type: SMD 2016 (4PIN)

标称频率:  
Nominal Freq: 32.000000MHz

产品编号:  
Part Coding: 7216-3200A0910-00

规格书编号:  
Specification P/N: XTY0292-7010

客户料号:  
Customer P/N: C389797

日期:  
Date: 2019-06-15

客户承认

Approved By Customer:

签章

Signature:

日期

Date:



### 深圳市新天源电子有限公司

SHENZHEN XINTIANYUAN ELECTRONICS CO., LTD.

地 址: 深圳市宝安区石岩镇塘头宏发工业园1栋5楼

Add: 5/f.,Block 1,Hongfa Industrial Estate,Tangtou village,Shiyan Town,Baoan district,Shenzhen,Guangdong,China.

电话Tel: 0755-27650903 传真Fax: 0755-29833253

联系人: 王后勤 (小姐) 手机: 13728612903

E-mail: [xyt@chinaxyty.cn](mailto:xyt@chinaxyty.cn) 网 址: [//www.chinaxyty.cn](http://www.chinaxyty.cn)

批准  
Accepted

审核  
Checked

编制  
Issued 陈梅东



<p>深圳市新天源电子有限公司</p> <p>Shenzhen Xintianyuan Electronics Co., Ltd.</p>	<p>石英晶体谐振器规格书</p> <p>Specification of Quartz Crystal</p>	<p>NO: XTY0292-7010</p>
	<p>无源 SMD 2016(4PIN)</p>	<p>Date: 2019/06/15</p>
<p>一、石英晶体规格参数</p> <p>Quartz Crystal Specification Parameters</p>		
<p>1、产品型号</p> <p>Holder Type</p>	<p>SMD 2016(4PIN)</p>	
<p>2、标称频率</p> <p>Nominal Frequency</p>	<p>32.000000MHz</p>	
<p>3、振动模式：</p> <p>Mode of Oscillation</p>	<p>Fundamental</p>	
<p>4、调整频差</p> <p>Frequency Tolerance at 25°C ±2°C</p>	<p>±10ppm at 25°C ±2°C</p>	
<p>5、等效电阻</p> <p>Equivalent Resistance(ESR)</p>	<p>≤60 Ω</p>	
<p>6、负载电容</p> <p>Load Capacitance(CL)</p>	<p>9pF</p>	
<p>7、温度频差</p> <p>Temperature Characteristics</p>	<p>±20ppm</p>	
<p>8、工作温度范围</p> <p>Operating Temperature range</p>	<p>-40~+85°C</p>	
<p>9、储存温度范围</p> <p>Storage Temperature range</p>	<p>-55~+125°C</p>	
<p>10、激励功率</p> <p>Drive Level</p>	<p>100uW</p>	
<p>11、静态电容</p> <p>Shunt Capacitance (C0)</p>	<p>&lt;4.0pF</p>	
<p>12、绝缘电阻</p> <p>Insulation Resistance</p>	<p>≥500MΩ (DC100V ±15V)</p>	
<p>13、测试仪器</p> <p>Measure Instrument</p>	<p>250B</p>	
<p>14、年老化率</p> <p>Aging Rate a Year</p>	<p>≤±3ppm/年</p>	

深圳市新天源电子有限公司 Shenzhen Xintianyuan Electronics Co., Ltd.	石英晶体谐振器规格书 Specification of Quartz Crystal	NO: XTY0292-7010
	无源 SMD 2016(4PIN)	Date: 2019/06/15

## 二、石英晶体尺寸、结构

### Quartz Crystal Dimensions And Structure

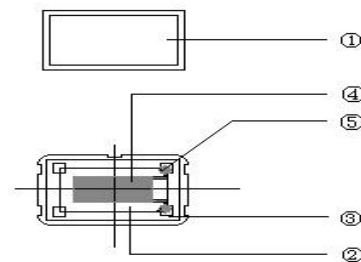
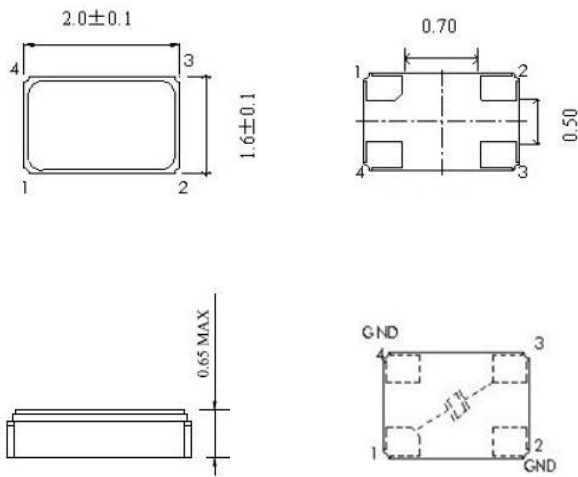

NO	NAME	名称
①	CAN	外壳
②	BASE	基座
③	LEAD	焊点
④	BLANK	晶片
⑤	RESIN	导电胶

## 三、石英晶体印字

### Quartz Crystal Marking

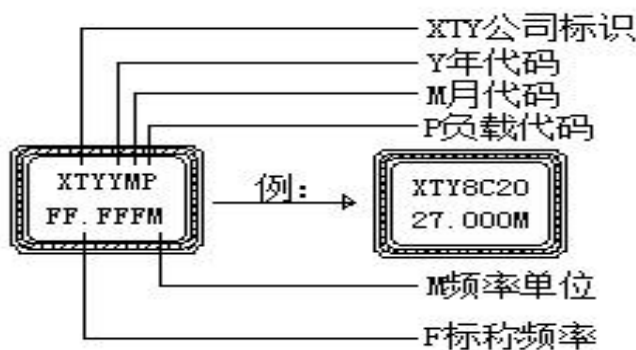

#### 印字: Marking

XTY: 新天源

Y为年(year): 8:2018; 9:2019...

M为月(Month): A:1; B:2...

P为负载 CL:20: 20pF

FF.FFFM为频率Frequency: 27.000M

例8C20: 8为2018年, C为3月, 20为20pF;

年、月、负载代码:

年	2015	2016	2017	2018	2019	2020	2021	2022	2023	2024	2025	2026
代码	5	6	7	8	9	0	1	2	3	4	5	6
月	1	2	3	4	5	6	7	8	9	10	11	12
代码	A	B	C	D	E	F	G	H	I	J	K	L
负载	9pF	10pF	11pF	12pF	13pF	14pF	15pF	16pF	17pF	18pF	19pF	SERIES
代码	9	10	11	12	13	14	15	16	17	18	19	S

深圳市新天源电子有限公司 Shenzhen Xintianyuan Electronics Co., Ltd.	石英晶体谐振器规格书 Specification of Quartz Crystal	NO: XTY0292-7010
	无源 SMD 2016(4PIN)	Date: 2019/06/15

四、包装要求  
Packaging

1. 编带  
Tape

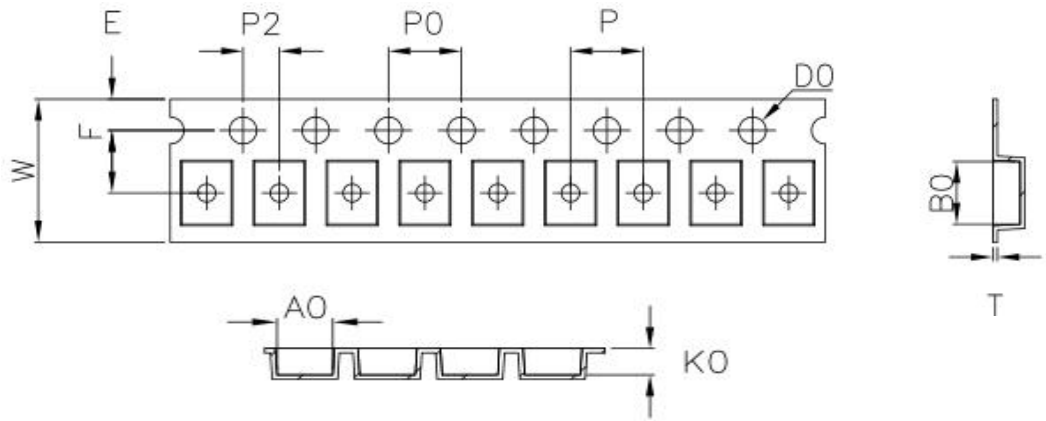

Type	W	E	F	T	P	P0	P2	DO	AO	KO	BO
SMD 2016	8.00	1.75	3.50	0.25	4.00	4.00	2.00	1.50	1.90	0.65	2.30

Unit:mm

2. 轮  
Reel

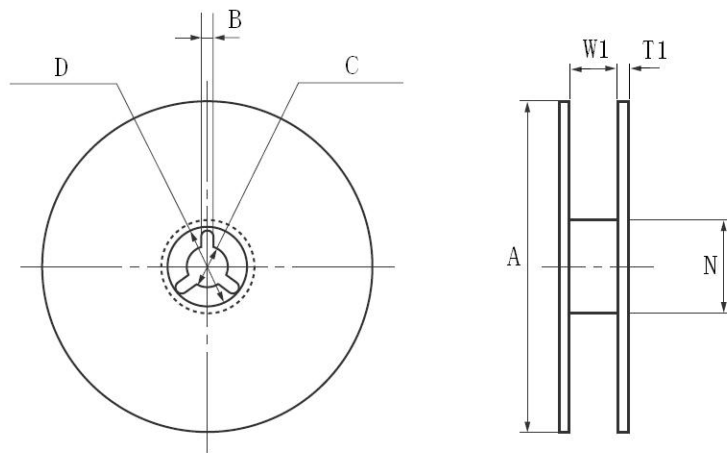

Type	A	B	C	D	N	W1	T1
SMD 2016	ø178	2.5	ø13	ø22.2	ø60	8.5	1.0

Unit:mm

深圳市新天源电子有限公司 Shenzhen Xintianyuan Electronics Co., Ltd.	石英晶体谐振器规格书 Specification of Quartz Crystal	NO: XTY0292-7010
	无源 SMD 2016(4PIN)	Date: 2019/06/15

3. 包装  
Package

3000只/1卷  
3000pcs/Reel

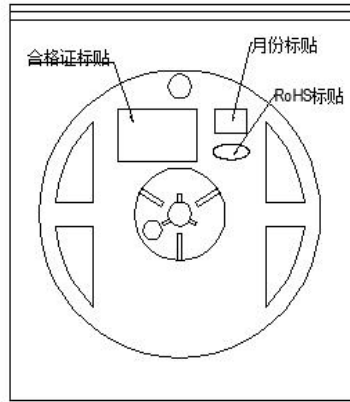

1轮=1盒  
1Reel=1Box  
Units: mm

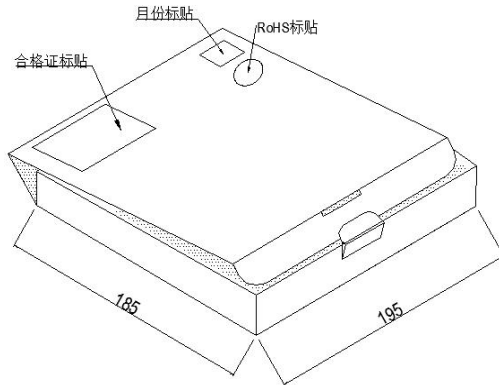

合格证	
频率:	型号:
负载:	电阻:
频差:	数量:
日期:	供应商:
批号:	编号:
订单号:	料号:

包装箱  
Shipping Carton

40\*34\*21.5 (20 Box)  
27\*20\*32.2 (12 Box)  
27\*20\*20 (8 Box)  
Units: cm

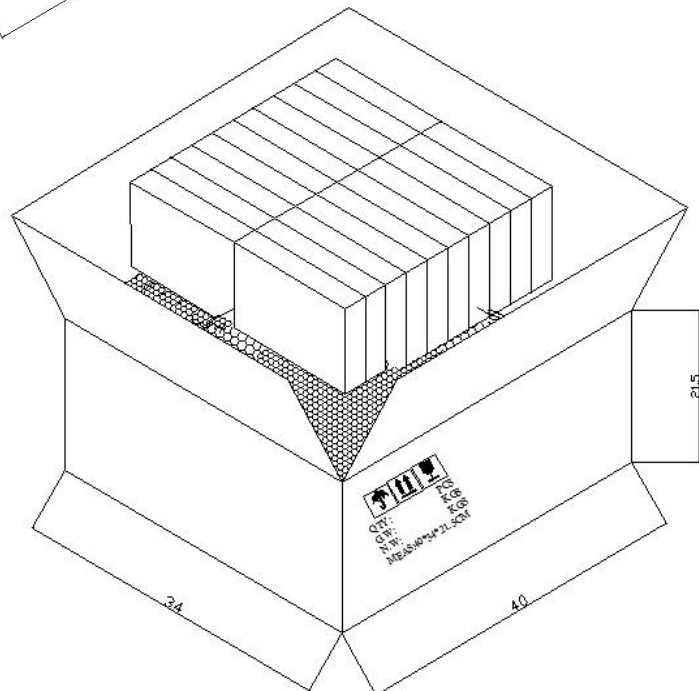

深圳市新天源电子有限公司 Shenzhen Xintianyuan Electronics Co., Ltd.	石英晶体谐振器规格书 Specification of Quartz Crystal	NO: XTY0292-7010
	无源 SMD 2016(4PIN)	Date: 2019/06/15

**五、石英晶体可靠性  
Reliability Test**

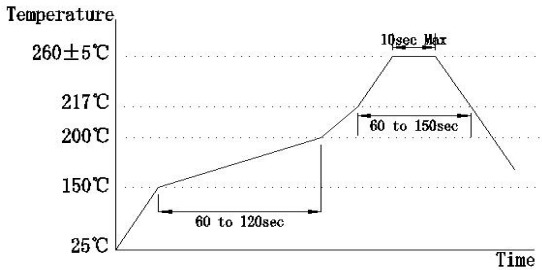
NO.	测试项目 Test Item	可靠性条件 Testing Condition	判定标准 Determinant Criteria
1.	跌落 Dropping Test	从75cm高度跌落到30mm厚硬木板上, 跌落三次 Drop the resonators from 75cm height to 30mm thick hardwood board, 3times.	$\Delta FL \leq \pm 5\text{ppm}$ $\Delta RS \leq \pm 10\%$ or $5\Omega$ (whichever is larger)
2.	振动 Vibration	频率 Frequency:10~60Hz; 幅度 Amplitude:0.75mm; 周期 Cycle time:10-55-10Hz: 1min; 振动方向 Direction:X, Y, Z; 振动时间 Duration: 每个方向2小时 2 h/direction.	$\Delta FL \leq \pm 5\text{ppm}$ $\Delta RS \leq \pm 10\%$ or $5\Omega$ (whichever is larger)
3.	高温 Heat Resistance	温度Temperature: $125^\circ\text{C} \pm 10^\circ\text{C}$ 时间Time: $720 \pm 24$ Hours	$\Delta FL \leq \pm 5\text{ppm}$ $\Delta RS \leq \pm 10\%$ or $5\Omega$ (whichever is larger)
4.	低温 Cold Resistance	温度Temperature: $-40^\circ\text{C} \pm 10^\circ\text{C}$ 时间Time: $720 \pm 24$ Hours	$\Delta FL \leq \pm 5\text{ppm}$ $\Delta RS \leq \pm 10\%$ or $5\Omega$ (whichever is larger)
5.	回流焊 (2次) Reflow (2times)	 <p>回流焊Reflow <math>260^\circ\text{C} \pm 5^\circ\text{C} \leq 10\text{s}</math></p>	$\Delta FL \leq \pm 5\text{ppm}$ $\Delta RS \leq \pm 10\%$ or $5\Omega$ (whichever is larger)
6.	耐焊接热 Resistance To Soldering Heat	焊接温度Soldering Heat: $320^\circ\text{C} \pm 10^\circ\text{C}$ 测试时间Test Time: $3.5\text{s} \pm 0.5\text{s}$ ;	$\Delta FL \leq \pm 5\text{ppm}$ $\Delta RS \leq \pm 10\%$ or $5\Omega$ (whichever is larger)
7.	气密性 Leakage	用氦质谱仪进行检测, 试验气体: He; 真空度: $1 \times 10^{-3}\text{Pa}$ ; Helium mass-mass-spectrometer detector, and vacuum and reach $1 \times 10^{-3}\text{Pa}$ ;	$\leq 1 \times 10^{-8}\text{atm} \cdot \text{cc/S}$
8.	高温高湿 Constant Temperature and Humidity	在温度 $60^\circ\text{C} \pm 5^\circ\text{C}$ , 湿度90%~99%, 储存720小时, 取出2小时后测试; Stored at $60^\circ\text{C} \pm 5^\circ\text{C}$ , Humidity 90%~99% For a period of minimum 720hours. Then $25^\circ\text{C} \pm 3^\circ\text{C}$ and 2 hours before testing	$\Delta FL \leq \pm 5\text{ppm}$ $\Delta RS \leq \pm 10\%$ or $5\Omega$ (whichever is larger) Appearance OK
9.	温度冲击 Temperature Shock	低温Low $-40^\circ\text{C} \pm 2^\circ\text{C}$ (120min) $\leftrightarrow$ 高温High $85^\circ\text{C} \pm 2^\circ\text{C}$ (120min); 循环10次; For 10 cycles	$\Delta FL \leq \pm 5\text{ppm}$ $\Delta RS \leq \pm 10\%$ or $5\Omega$ (whichever is larger)