

Data Sheet

Customer:

Product: Anti-Sulfurated Thick Film Chip Resistor - AS Series

Size: 0201/0402/0603/0805/1206/1210/2010/2512

Issued Date: 31-Oct-16

Edition: REV.B5



VIKING TECH CORPORATION
光韻科技股份有限公司

No.70 Guangfu N. Rd., Hukou
Township, Hsinchu County 303,
Taiwan

TEL:886-3-5972931

FAX:886-3-5972935•886-3-5973494

E-mail:sales@viking.com.tw

VIKING TECH CORPORATION KAOHSIUNG BRANCH
光韻科技股份有限公司高雄分公司

No.248-3, Sin-Sheng Rd., Cian-Jhen Dist., Kaohsiung,
806, Taiwan

TEL:886-7-8217999

FAX:886-7-8228229

E-mail:sales@viking.com.tw

WUXI TMTEC CO., LTD.

無錫泰銘電子有限公司

No.22 Xixia Road, Machinery & Industry Park,
National Hi-Tech Industrial Development Zone
of Wuxi, Wuxi, Jiangsu Province, China

Zip Code:214028

TEL:86-510-85203339

FAX:86-510-85203667•86-510-85203977

E-mail:china@viking.com.tw

Produced by (QC)	Checked (QC)	Approved by (QC)	Prepared by (Sales)	Accepted by (Customer)
31-Oct-16	31-Oct-16	31-Oct-16	31-Oct-16	
Susan Huang	J.C. Liu	J.C. Liu		

Anti-Sulfurated Thick Film Chip Resistor



Scope

- This specification applies to all sizes of rectangular-type fixed chip resistors with Ruthenium-base as material.

Features

- Special construction to prevent sulfuration in a sulfur containing environment

Construction

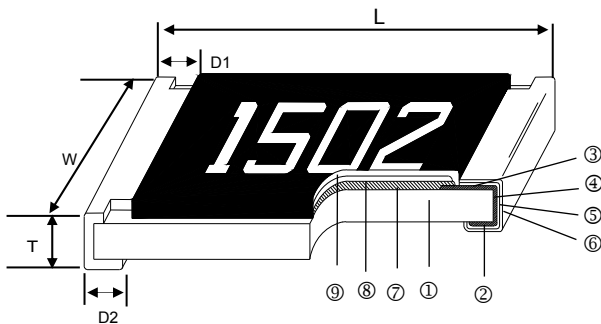

Applications

- High-end Computer
- Industrial Equipment
- Automatic Equipment Controller
- Medical Equipment
- High-end Multimedia Electronics
- Outdoor Electronic Applications

① Alumina Substrate	④ Edge Electrode	⑦ Resistor Layer
② Bottom Electrode	⑤ Barrier Layer	⑧ Primary Overcoat
③ Top Electrode	⑥ External Electrode	⑨ Secondary Overcoat

Dimensions

Type	Size (Inch)	L (mm)	W (mm)	T (mm)	D1 (mm)	D2 (mm)	Weight (g) (1000pcs)
AS01	0201	0.60±0.03	0.30±0.03	0.23±0.03	0.15±0.05	0.15±0.05	0.150
AS02	0402	1.00±0.05	0.50±0.05	0.35±0.05	0.20±0.10	0.20±0.10	0.620
AS03	0603	1.60±0.10	0.80±0.10	0.45±0.10	0.30±0.20	0.30±0.20	2.042
AS05	0805	2.00±0.10	1.25±0.10	0.50±0.10	0.35±0.20	0.40±0.20	4.368
AS06	1206	3.10±0.10	1.55±0.10	0.55±0.10	0.50±0.25	0.50±0.20	8.947
AS10	1210	3.10±0.10	2.60±0.15	0.55±0.10	0.50±0.25	0.50±0.20	15.959
AS0A	2010	5.00±0.10	2.50±0.15	0.55±0.10	0.60±0.25	0.50±0.20	24.241
AS12	2512	6.35±0.10	3.10±0.15	0.55±0.10	0.60±0.25	0.50±0.20	39.448

Part Numbering

AS	03	F	T	E		1003
Product Type	Dimensions	Resistance Tolerance	Packaging Code	TCR (PPM/°C)	Power Rating	Resistance
	01: 0201 02: 0402 03: 0603 05: 0805 06: 1206 10: 1210 0A: 2010 12: 2512	D: ±0.5% F: ±1% J: ±5%	T: Taping Reel	E: ±100 F: ±200 - : No Specified	: Standard L: 1/12W X: 1/10W W: 1/8W V: 1/4W O: 1/3W U: 1/2W T: 1W	R0R0: 0Ω 0010: 1Ω 1000: 100Ω 1002: 10KΩ 2201: 2.2KΩ 1003: 100KΩ 1004: 1MΩ

Recommend Land Pattern

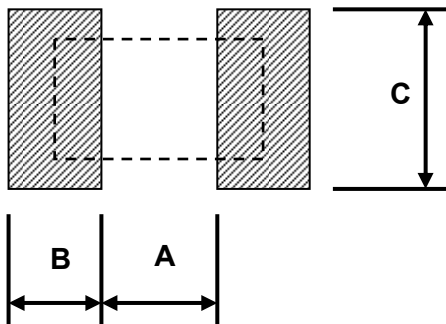

Type	A (mm)	B (mm)	C (mm)
AS01	0.30	0.25	0.30
AS02	0.50	0.45	0.60
AS03	0.90	0.60	0.90
AS05	1.20	0.70	1.30
AS06	2.00	0.90	1.60
AS10	2.00	0.90	2.80
AS0A	3.80	0.90	2.80
AS12	3.80	1.60	3.50

Derating Curve

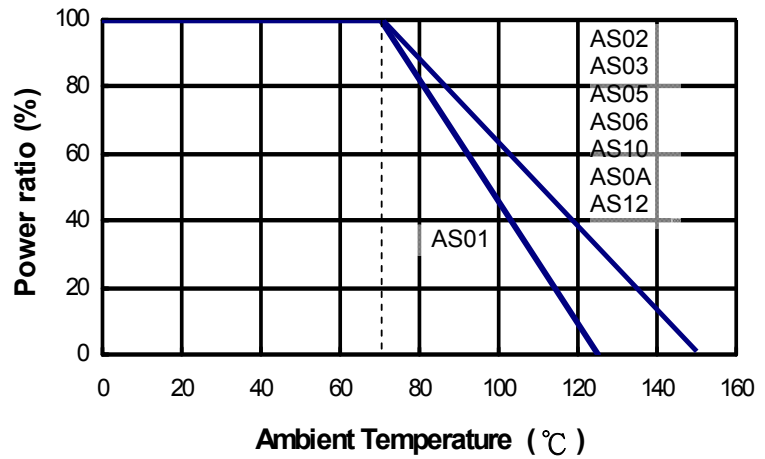

Soldering Condition

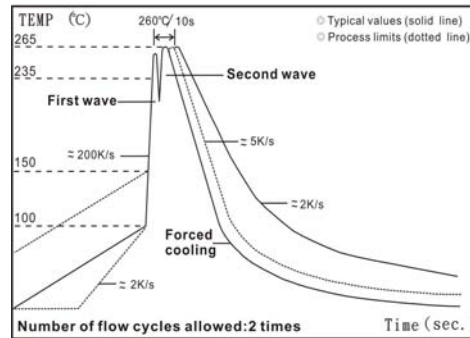
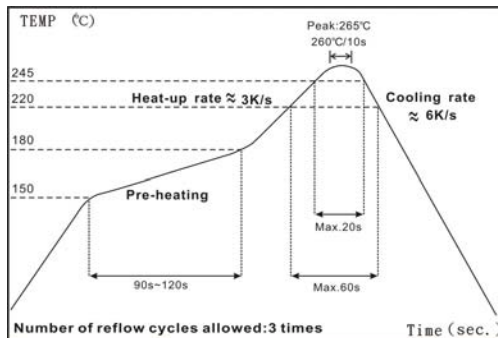

- (1) Time of IR reflow soldering at maximum temperature point 260°C : 10s
- (2) Time of wave soldering at maximum temperature point 260°C : 10s
- (3) Time of soldering iron at maximum temperature point 410°C : 5s

Standard Electrical Specifications

Item Type	Power Rating at 70°C Jumper Rated Current	Operating Temp. Range	Max. Operating Voltage	Max. Overload Voltage	Resistance Range			TCR (PPM/°C)
					±0.5%	±1%	±5%	
AS01 (0201)	1/20W	-55 ~ +125°C	25V	50V	-	1Ω - 10MΩ		±200
	Jumper: 1A				-	0Ω (<50mΩ)		-
AS02 (0402)	1/16W	-55 ~ +155°C	50V	100V	1Ω - 9.76Ω 10Ω - 1MΩ 1.02MΩ - 10MΩ			±200 ±100 ±200
	Jumper: 1A				0Ω (<50mΩ)			-
AS03 (0603)	1/10W		50V	100V	1Ω - 9.76Ω 10Ω - 1MΩ 1.02MΩ - 10MΩ			±200 ±100 ±200
	Jumper: 1A				0Ω (<50mΩ)			-
AS05 (0805)	1/8W		150V	300V	1Ω - 9.76Ω 10Ω - 1MΩ 1.02MΩ - 10MΩ			±200 ±100 ±200
	Jumper: 2A				0Ω (<50mΩ)			-
AS06 (1206)	1/4W		200V	400V	1Ω - 9.76Ω 10Ω - 1MΩ 1.02MΩ - 10MΩ			±200 ±100 ±200
	Jumper: 2A				0Ω (<50mΩ)			-
AS10 (1210)	1/3W		200V	400V	1Ω - 9.76Ω 10Ω - 1MΩ 1.02MΩ - 10MΩ			±200 ±100 ±200
	Jumper: 2.5A				0Ω (<50mΩ)			-
AS0A (2010)	3/4W		200V	400V	1Ω - 9.76Ω 10Ω - 1MΩ 1.02MΩ - 10MΩ			±200 ±100 ±200
	Jumper: 3.5A				0Ω (<50mΩ)			-
AS12 (2512)	1W	250V	500V	1Ω - 9.76Ω 10Ω - 1MΩ 1.02MΩ - 10MΩ			±200 ±100 ±200	
	Jumper: 4A			0Ω (<50mΩ)			-	

High Power Rating Electrical Specifications

Item Type	Power Rating at 70°C	Operating Temp. Range	Max. Operating Voltage	Max. Overload Voltage	Resistance Range		TCR (PPM/°C)
					±1% (E24、E96)	±5% (E24)	
AS01 (0201)	1/12W	-55 ~ +125°C	25V	50V	10Ω - 1MΩ		±200
AS02 (0402)	1/10W	-55 ~ +155°C	50V	100V	1Ω - 9.76Ω 10Ω - 1MΩ		±200 ±100
AS03 (0603)	1/8W		50V	100V			
AS05 (0805)	1/4W		150V	300V			
AS06 (1206)	1/3W		200V	400V			
AS10 (1210)	1/2W		200V	400V			
AS0A (2010)	1W		200V	400V			
			200V	400V			

Operating Voltage= $\sqrt{P \cdot R}$ or Max. Operating Voltage listed above, whichever is lower.

Overload Voltage= $2.5 \cdot \sqrt{P \cdot R}$ or Max. Overload Voltage listed above, whichever is lower.

■ Viking is capable of manufacturing the optional spec based on customer's requirement.

Environmental Characteristics

Item	Requirement			Test Method
	±1% and Below	±5%	Jumper	
Temperature Coefficient of Resistance (T.C.R.)	As Spec.			JIS-C-5201-1 4.8 IEC-60115-1 4.8 -55°C~+125°C, 25°C is the reference temperature
Short Time Overload	±(1.0%+0.05Ω)	±(2.0%+0.05Ω)	<50mΩ	JIS-C-5201-1 4.13 IEC-60115-1 4.13 RCWV*2.5 or Max. Overload Voltage whichever is lower for 5 seconds, 2 seconds for high power series
Insulation Resistance	≥10G			JIS-C-5201-1 4.6 IEC-60115-1 4.6 Max. Overload Voltage for 1 minute
Endurance	±(2.0%+0.10Ω)	±(3.0%+0.10Ω)	<100mΩ	JIS-C-5201-1 4.25 IEC-60115-1 4.25.1 70±2°C, RCWV for 1000 hrs with 1.5 hrs "ON" and 0.5 hr "OFF"
Damp Heat with Load	±(2.0%+0.10Ω)	±(3.0%+0.10Ω)	<100mΩ	JIS-C-5201-1 4.24 IEC-60115-1 4.24 40±2°C, 90~95% R.H., RCWV for 1000 hrs with 1.5 hrs "ON" and 0.5 hr "OFF"
Dry Heat	±(1.0%+0.05Ω)	±(1.5%+0.10Ω)	<50mΩ	JIS-C-5201-1 4.23 IEC-60115-1 4.23.2 at +125/+155°C for 1000 hrs
Bending Strength	±(1.0%+0.05Ω)	±(1.0%+0.05Ω)	<50mΩ	JIS-C-5201-1 4.33 IEC-60115-1 4.33 Bending once for 5 seconds 2010, 2512 sizes: 2mm Other sizes: 3mm
Solderability	95% min. coverage			JIS-C-5201-1 4.17 IEC-60115-1 4.17 245±5°C for 3 seconds
Resistance to Soldering Heat	±(0.5%+0.05Ω)	±(1.0%+0.05Ω)	<50mΩ	JIS-C-5201-1 4.18 IEC-60115-1 4.18 260±5°C for 10 seconds
Voltage Proof	No breakdown or flashover			JIS-C-5201-1 4.7 IEC-60115-1 4.7 1.42 times Max. Operating Voltage for 1 minute
Leaching	Individual leaching area ≤5% Total leaching area ≤ 10%			JIS-C-5201-1 4.18 IEC-60068-2-58 8.2.1 260±5°C for 30 seconds
Rapid Change of Temperature	±(0.5%+0.05Ω)	±(1.0%+0.05Ω)	<50mΩ	JIS-C-5201-1 4.19 IEC-60115-1 4.19 -55°C to +125/+155°C, 5 cycles
Sulfur Test	±(0.5%+0.05Ω)	±(0.5%+0.05Ω)	<50mΩ	ASTM-B-809-95 H2S, 50±2°C, 91~93% R.H., no power rating for 1000 hrs

RCWV(Rated Continuous Working Voltage)=√(P*R) or Max. Operating Voltage whichever is lower.

Storage Temperature: 15~28°C; Humidity < 80%RH

■Packaging

Reel Specifications & Packaging Quantity

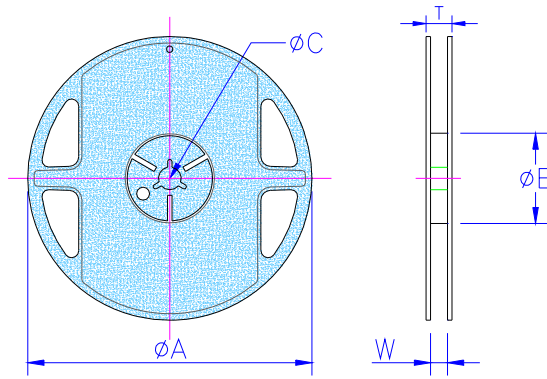

Type	Packaging Quantity	Tape Width	Reel Diameter	ΦA (mm)	ΦB (mm)	ΦC (mm)	W (mm)	T (mm)
AS01 AS02	Paper	10K	7 inch	178.5±1.5	60 ^{+1/-0}	13.0±0.2	9.0±0.5	12.5±0.5
		20K	10 inch	254±1.0	100±0.5	13.0±0.2	9.5±0.5	13.5±0.5
		40K	13 inch	330±1.0	100±0.5	13.0±0.2	9.5±0.5	13.5±0.5
AS03 AS05 AS06 AS10	Paper	5K	7 inch	178.5±1.5	60 ^{+1/-0}	13.0±0.2	9.0±0.5	12.5±0.5
		10K	10 inch	254±1.0	100±0.5	13.0±0.2	9.5±0.5	13.5±0.5
		20K	13 inch	330±1.0	100±0.5	13.0±0.2	9.5±0.5	13.5±0.5
AS0A AS12	Embossed	4K	7 inch	178.5±1.5	60 ^{+1/-0}	13.0±0.5	13.0±0.5	15.5±0.5
		8K	10 inch	250±1.0	62±0.5	13.0±0.5	12.5±0.5	16.5±0.5

Paper Tape Specifications

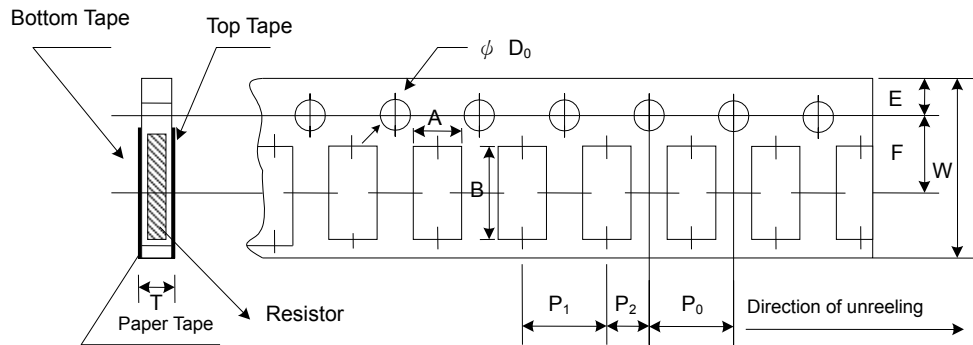

Type	A (mm)	B (mm)	W (mm)	E (mm)	F (mm)	P ₀ (mm)	P ₁ (mm)	P ₂ (mm)	ΦD ₀ (mm)	T (mm)
AS01	0.38±0.05	0.68±0.05	8.0±0.20	1.75±0.10	3.50±0.05	4.00±0.10	2.00±0.05	2.00±0.05	1.50+0.1,-0	0.42±0.20
AS02	0.65±0.10	1.15±0.10	8.0±0.20	1.75±0.10	3.50±0.05	4.00±0.10	2.00±0.05	2.00±0.05	1.50+0.1,-0	0.45±0.10
AS03	1.10±0.10	1.90±0.10	8.0±0.20	1.75±0.10	3.50±0.05	4.00±0.10	4.00±0.05	2.00±0.05	1.50+0.1,-0	0.70±0.10
AS05	1.60±0.10	2.40±0.20	8.0±0.20	1.75±0.10	3.50±0.05	4.00±0.10	4.00±0.05	2.00±0.05	1.50+0.1,-0	0.85±0.10
AS06	1.90±0.10	3.50±0.20	8.0±0.20	1.75±0.10	3.50±0.05	4.00±0.10	4.00±0.05	2.00±0.05	1.50+0.1,-0	0.85±0.10
AS10	2.90±0.10	3.50±0.20	8.0±0.20	1.75±0.10	3.50±0.05	4.00±0.10	4.00±0.05	2.00±0.05	1.50+0.1,-0	0.85±0.10

Embossed Plastic Tape Specifications

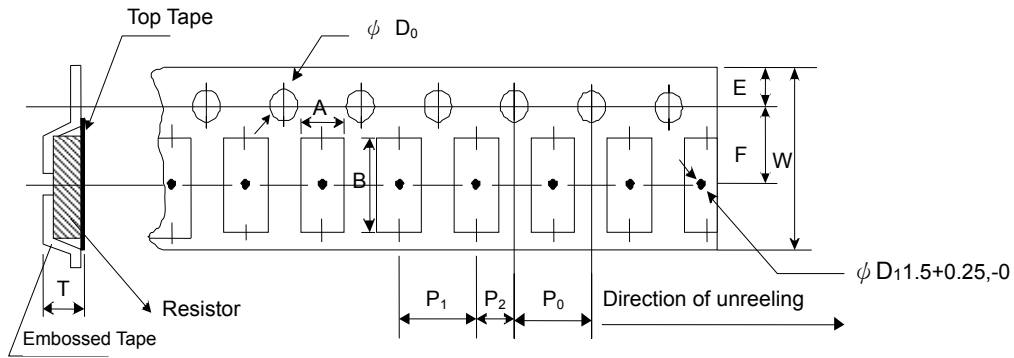

Type	A (mm)	B (mm)	W (mm)	E (mm)	F (mm)	P ₀ (mm)	P ₁ (mm)	P ₂ (mm)	ΦD ₀ (mm)	T (mm)
AS0A	2.8±0.10	5.5±0.10	12.0±0.30	1.75±0.10	5.5±0.05	4.00±0.10	4.00±0.10	2.00±0.05	1.50+0.1, -0	1.2 ⁺⁰
AS12	3.5±0.10	6.7±0.10	12.0±0.30	1.75±0.10	5.5±0.05	4.00±0.10	4.00±0.10	2.00±0.05	1.50+0.1, -0	1.2 ⁺⁰

■ Marking

No Marking for 0201 and 0402

Jumper for all: Letter "0"

1% for 0805/1206/1210/2010/2512: 4 digits marking

Example:

Resistance	100Ω	2.2KΩ	10KΩ	49.9KΩ	100KΩ
Marking	1000	2201	1002	4992	1003

5% for 0603/0805/1206/1210/2010/2512: 3 digits marking in E24

Example: 101=100Ω 102=1KΩ (1st and 2nd are E24 code and 3rd code is multiplier)

E24 code	10	11	12	13	15	16	18	20	22	24	27	30	33	36	39	43	47	51	56	62	68	75	82	91
----------	----	----	----	----	----	----	----	----	----	----	----	----	----	----	----	----	----	----	----	----	----	----	----	----

1% for 0603: 3 digits marking in E96



3 digits marking for Example: 14C=13K7Ω 13C=13K3Ω
68B=4K99Ω 68X=49.9Ω

Marking Table

Code	E96		Code	E96		Code	E96		Code	E96	
01	100		25	178		49	316		73	562	
02	102		26	182		50	324		74	576	
03	105		27	187		51	332		75	590	
04	107		28	191		52	340		76	604	
05	110		29	196		53	348		77	619	
06	113		30	200		54	357		78	634	
07	115		31	205		55	365		79	649	
08	118		32	210		56	374		80	665	
09	121		33	215		57	383		81	681	
10	124		34	221		58	392		82	698	
11	127		35	226		59	402		83	715	
12	130		36	232		60	412		84	732	
13	133		37	237		61	422		85	750	
14	137		38	243		62	432		86	768	
15	140		39	249		63	442		87	787	
16	143		40	255		64	453		88	806	
17	147		41	261		65	464		89	825	
18	150		42	267		66	475		90	845	
19	154		43	274		67	487		91	866	
20	158		44	280		68	499		92	887	
21	162		45	287		69	511		93	909	
22	165		46	294		70	523		94	931	
23	169		47	301		71	536		95	953	
24	174		48	309		72	549		96	976	
Code	A	B	C	D	E	F	G	X	Y		
Multiplier	10 ⁰	10 ¹	10 ²	10 ³	10 ⁴	10 ⁵	10 ⁶	10 ⁻¹	10 ⁻²		

REVISION HISTORY

REVISION	DATE	CHANGE NOTIFICATION	DESCRIPTION
Version B3	Jun 03, 2014	-	- Environmental Characteristics updated
Version B4	Jul 15, 2016	-	- Remove Material Description - Modify Storage Temperature
Version B5	Oct 31, 2016	-	- Increase High Power Rating Electrical Specifications