

TLG Series

• 105°C 3,000Hrs assured.

- Non-solvent proof
- High Ripple, Low Temp.
- For SMPS, Inverter.
- RoHS compliant.
- Halogen-free capacitors are also available.



SPECIFICATIONS

Item	Characteristics		
Rated Voltage Range	160 ~ 500 V _{dc}		
Operating Temperature Range	-40 ~ +105°C		
Capacitance Tolerance	±20%(M) (at 20°C, 120Hz)		
Leakage Current	$I = 3\sqrt{CV} (\mu A)$ Where, I: Leakage Current(μA), C: Nominal capacitance(μF), V: Rated voltage(V _{dc}) (at 20°C, 5minutes)		
※ Dissipation Factor(Tanδ)	Rated voltage(V _{dc})	160~400	450~500
	Tanδ(Max.)	0.15	0.20
	(at 20°C, 120Hz)		
Temperature Characteristics (Max. Impedance ratio)	Rated voltage(V _{dc})	160~400	450~500
	Z(-25°C)/Z(20°C)	4	8
	Z(-40°C)/Z(20°C)	8	16
	(at 120Hz)		
Load Life	The following specifications shall be satisfied when the capacitors are restored to 20°C after the rated voltage with the rated ripple current is applied (the peak voltage shall not exceed the rated voltage) for 3,000 hours at 105°C Capacitance change ≤ ±20% of the initial value Tanδ ≤ 200% of the initial specified value Leakage current ≤ The initial specified value		
Shelf Life	The following specifications shall be satisfied when the capacitors are restored to 20°C after the exposing them at 105°C for 1,000hours without voltage applied. The rated voltage shall be applied to the capacitors for a minimum of 30 minutes, at least 24 hours and not more than 48 hours before the measurements. Capacitance change ≤ ±20% of the initial value Tanδ ≤ 200% of the initial specified value Leakage current ≤ The initial specified value		
Others	Satisfied characteristics KS C IEC 60384-4		

※ For capacitors with CV products >100,000 higher Tanδ value may apply.

When the capacitance exceeds 1,000μF, 0.01 shall be added every 1,000μF increase.

RATED RIPPLE CURRENT

When capacitor are operated in any other condition at 120Hz, the maximum ripple current must be multiplied by the figure shown in the table.

Frequency multiplying factor

V _{dc}	Freq.(Hz)	60	120	300	1k	10k~
160~250		0.81	1.00	1.17	1.32	1.45
350~500		0.77	1.00	1.16	1.30	1.41

DIMENSIONS OF TLG Series

Unit(mm)

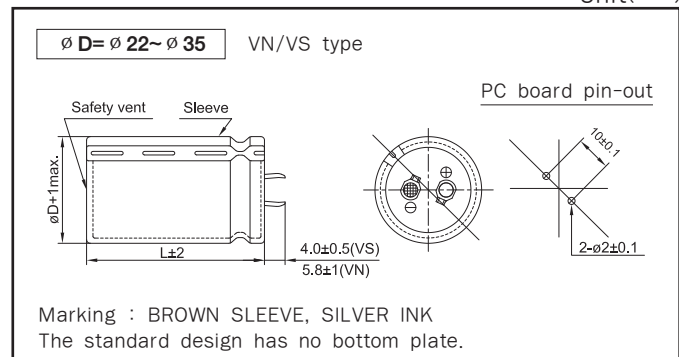

RATINGS OF TLG Series

VDC	Capacitance (μF)	∅D×L(mm)	Rated Ripple Current (Arms/105°C, 120Hz)	VDC	Capacitance (μF)	∅D×L(mm)	Rated Ripple Current (Arms/105°C, 120Hz)
160	330	22 × 25	1.20	350	100	22 × 25	0.73
	470	22 × 30	1.47		150	22 × 30	0.91
		25.4 × 25	1.46		180	25.4 × 25	0.91
	560	22 × 35	1.66			22 × 35	1.03
	680	22 × 40	1.87		220	22 × 40	1.16
		25.4 × 30	1.82			25.4 × 30	1.14
		30 × 25	1.85			30 × 25	1.16
	820	22 × 45	2.11		270	22 × 50	1.36
		25.4 × 35	2.06			25.4 × 40	1.33
		22 × 50	2.31			30 × 30	1.33
	1,000	25.4 × 40	2.28		330	35 × 25	1.34
		30 × 30	2.27			25.4 × 45	1.52
		35 × 25	2.29			25.4 × 50	1.69
	1,200	25.4 × 45	2.57		390	30 × 35	1.65
		30 × 35	2.57			35 × 30	1.68
	1,500	30 × 40	2.96		470	30 × 40	1.87
35 × 30		2.91	35 × 35	1.91			
1,800	30 × 45	3.34	560	30 × 50	2.16		
	35 × 35	3.30		35 × 40	2.15		
2,200	35 × 45	3.78	680	35 × 45	2.44		
2,700	35 × 50	4.07	820	35 × 50	2.76		
200	270	22 × 25	1.15	400	100	22 × 25	0.73
	390	22 × 30	1.43		120	22 × 30	0.82
		25.4 × 25	1.42		150	25.4 × 25	0.81
	470	22 × 35	1.60			22 × 35	0.94
	560	22 × 40	1.80		180	22 × 40	1.05
		25.4 × 30	1.75			25.4 × 30	1.03
	680	30 × 25	1.80		30 × 25	1.05	
		22 × 45	2.04		220	22 × 45	1.20
	25.4 × 35	1.99	25.4 × 35			1.17	
	820	22 × 50	2.17		270	22 × 50	1.36
		25.4 × 40	2.26			25.4 × 40	1.33
		30 × 30	2.26			30 × 30	1.33
	1,000	35 × 25	2.27		330	35 × 25	1.34
		25.4 × 50	2.48			25.4 × 45	1.52
	1,200	30 × 35	2.49		390	30 × 35	1.52
		30 × 40	2.81			25.4 × 50	1.69
1,500	35 × 30	2.77	470	30 × 40	1.70		
	30 × 50	3.23		35 × 30	1.68		
1,800	35 × 40	3.32	560	30 × 45	1.93		
	35 × 45	3.75		35 × 35	1.91		
2,200	35 × 50	4.01	680	30 × 50	2.16		
250	180	22 × 25	0.97	450	68	22 × 25	0.57
	270	22 × 30	1.23		100	22 × 30	0.71
		25.4 × 25	1.22		120	25.4 × 25	0.71
	330	22 × 35	1.39			22 × 35	0.80
	390	22 × 40	1.55		150	22 × 40	0.92
		25.4 × 30	1.51			25.4 × 30	0.90
	470	30 × 25	1.54		180	30 × 25	0.92
		22 × 45	1.75			22 × 45	1.04
	560	25.4 × 35	1.71		220	25.4 × 35	1.01
		22 × 50	1.96			25.4 × 40	1.15
		25.4 × 40	1.92			30 × 30	1.15
	680	30 × 30	1.91		270	35 × 25	1.16
		35 × 25	1.93			25.4 × 50	1.35
		25.4 × 50	2.24			30 × 40	1.36
	820	30 × 35	2.18		330	35 × 30	1.34
		35 × 30	2.22			30 × 45	1.55
30 × 40		2.47	35 × 35	1.53			
1,000	35 × 35	2.52	390	30 × 50	1.73		
	30 × 50	2.89		35 × 40	1.72		
1,200	35 × 40	2.87					
1,500	35 × 45	3.25					
	35 × 50	3.73					

RATINGS OF TLG Series

VDC	Capacitance (μF)	∅D×L(mm)	Rated Ripple Current (Arms/105°C, 120Hz)
450	470	35 × 45	1.95
	560	35 × 50	2.18
500	47	22 × 25	0.43
		22 × 30	0.52
	56	25.4 × 25	0.50
		22 × 35	0.60
	68	22 × 40	0.65
		25.4 × 30	0.67
		30 × 25	0.72
	100	22 × 45	0.74
		25.4 × 35	0.77
	120	22 × 50	0.85
		25.4 × 40	0.85
		30 × 30	0.86
		35 × 25	0.88
	150	25.4 × 45	0.98
		30 × 35	0.97
	180	25.4 × 50	1.12
		30 × 40	1.13
		35 × 30	1.15
	220	30 × 45	1.22
		35 × 35	1.24
270	30 × 50	1.34	
	35 × 40	1.37	
330	35 × 45	1.62	
390	35 × 50	1.84	