

SE6003C

N-Channel Enhancement-Mode MOSFET

Revision: A

General Description

Thigh Density Cell Design For Ultra Low On-Resistance Fully Characterized Avalanche Voltage and Current Improved Shoot-Through FOM

- Simple Drive Requirement
- Small Package Outline
- Surface Mount Device

Features

For a single MOSFET

- $V_{DS} = 60V$
- $R_{DS(ON)} = 85m\Omega @ V_{GS}=10V$
- $R_{DS(ON)} = 105m\Omega @ V_{GS}=4.5V$

Pin configurations

See Diagram below

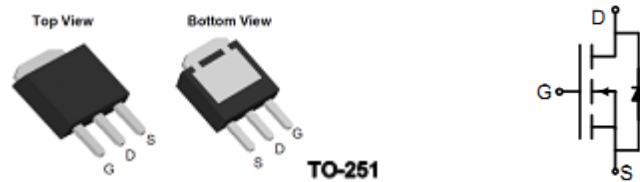

Absolute Maximum Ratings

Parameter		Symbol	Rating	Units
Drain-Source Voltage		V_{DS}	60	V
Gate-Source Voltage		V_{GS}	± 20	V
Drain Current	Continuous	I_D	3	A
	Pulsed		10	
Total Power Dissipation	@TA=25°C	P_D	1.7	W
Operating Junction Temperature Range		T_J	-55 to 150	°C

Thermal Resistance

Symbol	Parameter	Typ	Max	Units
$R_{\theta JA}$	Junction to Ambient ($t \leq 10s$)	-	73.5	°C/W

SE6003C

Electrical Characteristics (T _J =25°C unless otherwise noted)						
Symbol	Parameter	Test Conditions	Min	Typ	Max	Units
OFF CHARACTERISTICS (Note 2)						
B _V DSS	Drain-Source Breakdown Voltage	I _D =250μA, V _{GS} =0 V	60			V
I _{DSS}	Drain to Source Leakage Current	V _{DS} = 60V, V _{GS} =0V			1	μA
I _{GSS}	Gate-Body Leakage Current	V _{GS} =20 V			100	nA
V _{GS(th)}	Gate Threshold Voltage	V _{DS} = V _{GS} , I _D =250μA	0.5	1.0	2.5	V
g _{fs}	Forward Transconductance	V _{DS} = 10V, I _D =3A		7		S
R _{DS(ON)}	Static Drain-Source On-Resistance ²	V _{GS} =10V, I _D =3A		85	100	mΩ
		V _{GS} =4.5V, I _D =3A		105	125	
DYNAMIC PARAMETERS						
C _{iss}	Input Capacitance	V _{GS} =0V, V _{DS} =25V, f=1MHz		247		pF
C _{oss}	Output Capacitance			34		pF
C _{rss}	Reverse Transfer Capacitance			19.5		pF
SWITCHING PARAMETERS						
Q _g	Total Gate Charge	V _{GS} =4.5V, V _{DS} =30V, I _D =1.5A		6		nC
Q _{gs}	Gate Source Charge			1		nC
Q _{gd}	Gate Drain Charge			1.3		nC
t _{d(on)}	Turn-On Delay Time	V _{GS} =10V, V _{DS} =30V, R _{GEN} =3.3Ω I _D =1A		6		ns
t _{d(off)}	Turn-Off Delay Time			15		ns
t _{d(r)}	Turn-On Rise Time			15		ns
t _{d(f)}	Turn-Off Fall Time			10		ns
Source-Drain Diode						
Symbol	Parameter	Test Condition	Min	Typ	Max	Units
V _{SD}	Forward On voltage ²	I _S =3A, V _{GS} =0V			1.3	V
t _{rr}	Reverse Recovery Time	I _S =3A, V _{GS} =0V		21		ns
Q _{rr}	Reverse Recovery Charge	dI/dt=100A/		19		nC

Note 1: Pulse width limited by Max. junction temperature

Note 2: Pulse test

Note 3: Surface mounted on 1 1n² copper pad of FR4 board; 270°C/W when mounted on min. copper pad

Typical Characteristics

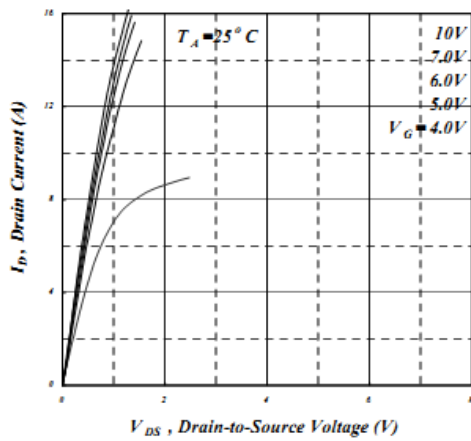

Fig 1. Typical Output Characteristics

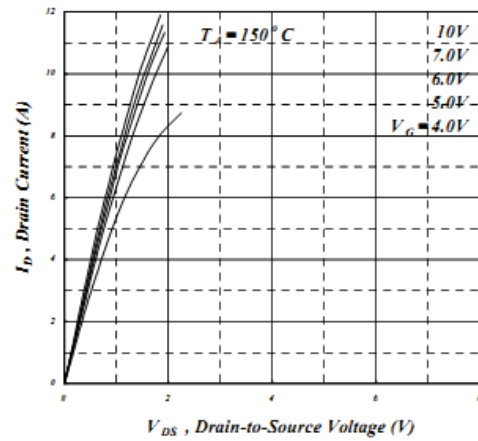

Fig 2. Typical Output Characteristics

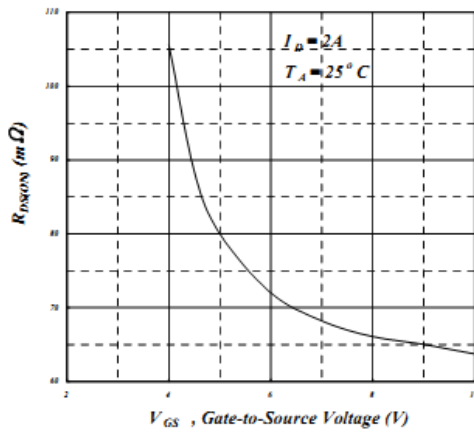

Fig 3. On-Resistance v.s. Gate Voltage

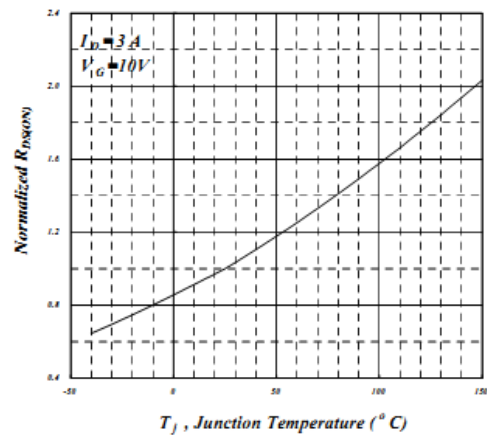

Fig 4. Normalized On-Resistance v.s. Junction Temperature

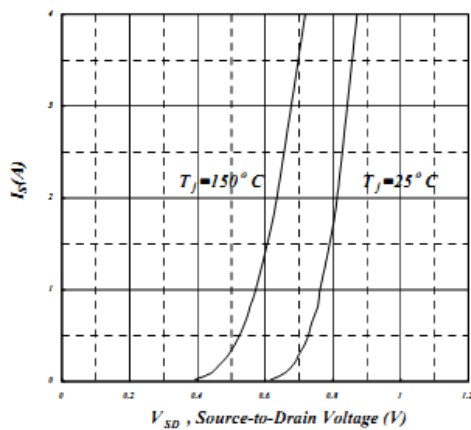

Fig 5. Forward Characteristic of Reverse Diode

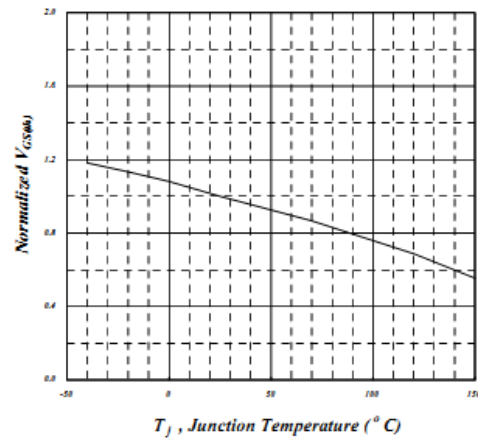

Fig 6. Gate Threshold Voltage v.s. Junction Temperature

Typical Characteristics

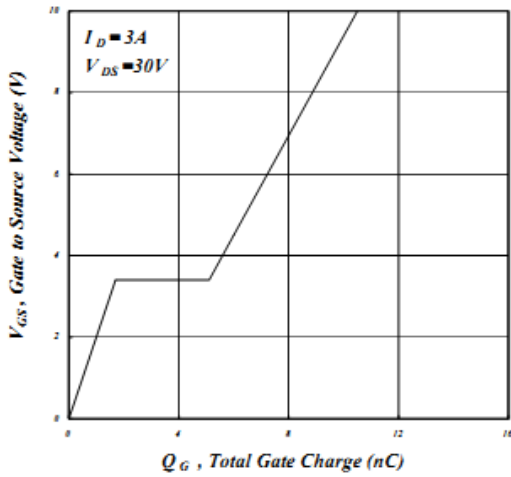

Fig 7. Gate Charge Characteristics

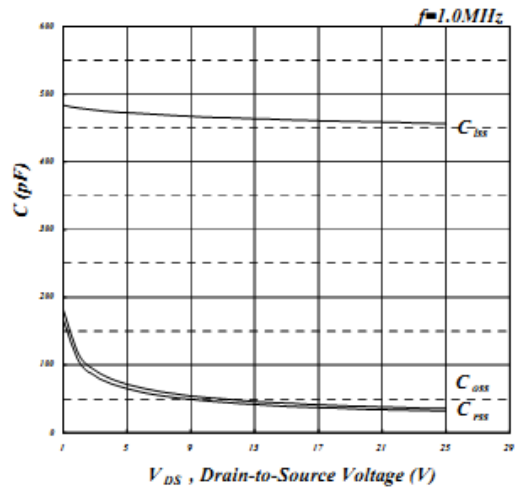

Fig 8. Typical Capacitance Characteristics

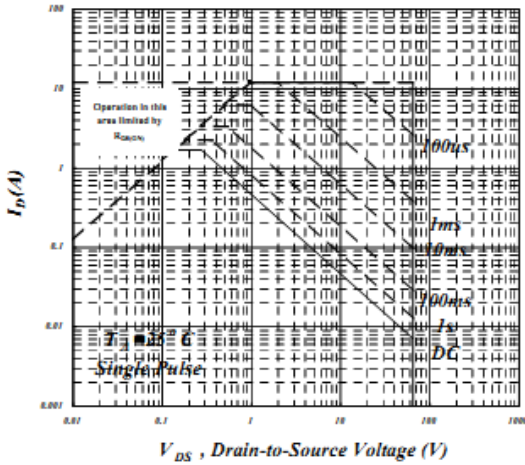

Fig 9. Maximum Safe Operating Area

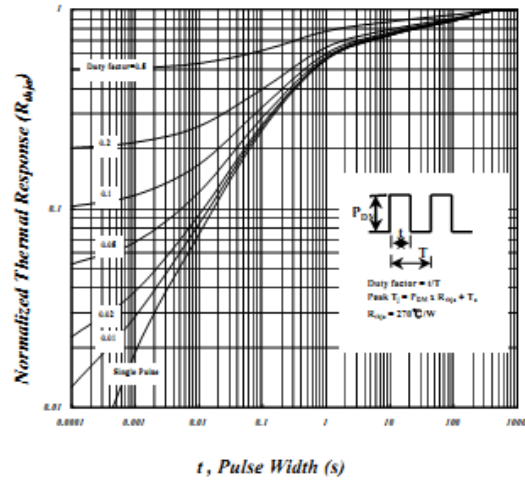

Fig 10. Effective Transient Thermal Impedance

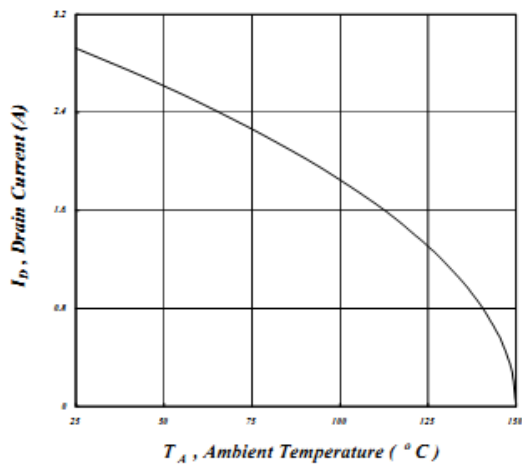

Fig 11. Maximum Continuous Drain Current v.s. Ambient Temperature

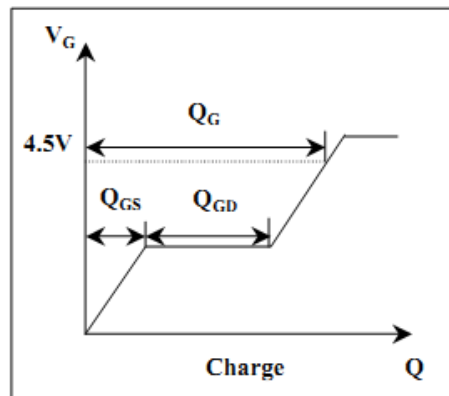
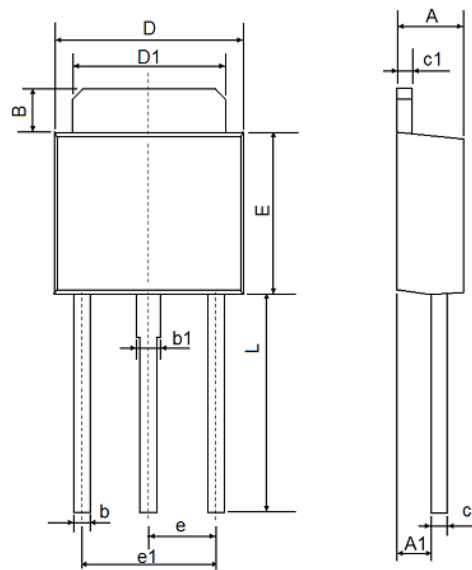

Fig 12. Gate Charge Waveform

SE6003C

Package Outline Dimension

TO-251



Symbol	Dimensions In Millimeters		Dimensions In Inches	
	Min.	Max.	Min.	Max.
A	2.200	2.400	0.087	0.094
A1	1.050	1.350	0.042	0.054
B	1.350	1.650	0.053	0.065
b	0.500	0.700	0.020	0.028
b1	0.700	0.900	0.028	0.035
c	0.430	0.580	0.017	0.023
c1	0.430	0.580	0.017	0.023
D	6.350	6.650	0.250	0.262
D1	5.200	5.400	0.205	0.213
E	5.400	5.700	0.213	0.224
e	2.300 TYP.		0.091 TYP.	
e1	4.500	4.700	0.177	0.185
L	7.500	7.900	0.295	0.311

The SINO-IC logo is a registered trademark of ShangHai Sino-IC Microelectronics Co., Ltd.

© 2005 SINO-IC - Printed in China - All rights reserved.

SHANGHAI SINO-IC MICROELECTRONICS CO., LTD

Add: Building 3, Room 3401-03, No.200 Zhangheng Road,
ZhangJiang Hi-Tech Park, Pudong, Shanghai 201203, China

Phone: +86-21-33932402 33932403

33932405 33933508 33933608

Fax: +86-21-33932401

Email: szrxw002@126.com

Website: <http://www.sino-ic.net>