







## Lonten N-channel 650V, 11A, 0.38Ω LonFET™ Power MOSFET

<p><b>Description</b> LonFET™ Power MOSFET is fabricated using advanced super junction technology. The resulting device has extremely low on resistance, making it especially suitable for applications which require superior power density and outstanding efficiency.</p> <p><b>Features</b></p> <ul style="list-style-type: none"> <li>◆ Ultra low <math>R_{DS(on)}</math></li> <li>◆ Ultra low gate charge (typ. <math>Q_g = 14.7\text{nC}</math>)</li> <li>◆ 100% UIS tested</li> <li>◆ RoHS compliant</li> </ul> <p><b>Applications</b></p> <ul style="list-style-type: none"> <li>◆ Power factor correction (PFC).</li> <li>◆ Switched mode power supplies (SMPS).</li> <li>◆ Uninterruptible power supply (UPS).</li> </ul>	<p><b>Product Summary</b></p> <table style="width: 100%; border: none;"> <tr> <td style="padding: 2px;"><math>V_{DS} @ T_{j,max}</math></td> <td style="padding: 2px;">700V</td> </tr> <tr> <td style="padding: 2px;"><math>R_{DS(on),max}</math></td> <td style="padding: 2px;">0.38Ω</td> </tr> <tr> <td style="padding: 2px;"><math>I_{DM}</math></td> <td style="padding: 2px;">30A</td> </tr> <tr> <td style="padding: 2px;"><math>Q_{g,typ}</math></td> <td style="padding: 2px;">14.7 nC</td> </tr> </table> <div style="display: flex; justify-content: space-around; align-items: center; margin-top: 10px;"> <div style="text-align: center;">   <b>TO-263</b> </div> <div style="text-align: center;">   <b>TO-252</b> </div> <div style="text-align: center;">   <b>TO-220</b> </div> <div style="text-align: center;">   <b>TO-220MF</b> </div> </div> <div style="display: flex; justify-content: space-around; align-items: center; margin-top: 10px;"> <div style="text-align: center;">   <b>TO-262</b> </div> <div style="text-align: center;">   <b>N-Channel MOSFET</b> </div> <div style="text-align: center;">  </div> </div>	$V_{DS} @ T_{j,max}$	700V	$R_{DS(on),max}$	0.38Ω	$I_{DM}$	30A	$Q_{g,typ}$	14.7 nC
$V_{DS} @ T_{j,max}$	700V								
$R_{DS(on),max}$	0.38Ω								
$I_{DM}$	30A								
$Q_{g,typ}$	14.7 nC								

### Absolute Maximum Ratings

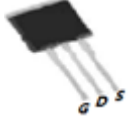
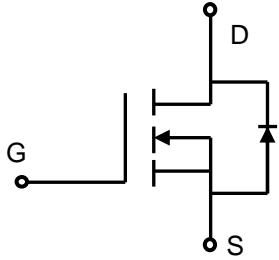
Parameter	Symbol	Value	Unit
Drain-Source Voltage	$V_{DSS}$	650	V
Continuous drain current ( $T_C = 25^\circ\text{C}$ ) ( $T_C = 100^\circ\text{C}$ )	$I_D$	11	A
		8.2	A
Pulsed drain current <sup>1)</sup>	$I_{DM}$	30	A
Gate-Source voltage	$V_{GSS}$	$\pm 30$	V
Avalanche energy, single pulse <sup>2)</sup>	$E_{AS}$	245	mJ
Avalanche current, repetitive <sup>3)</sup>	$I_{AR}$	11	A
Power Dissipation TO-220/TO-252/ TO-262/ TO-263 ( $T_C = 25^\circ\text{C}$ ) - Derate above $25^\circ\text{C}$	$P_D$	90	W
		0.72	W/ $^\circ\text{C}$
Power Dissipation TO-220MF ( $T_C = 25^\circ\text{C}$ ) - Derate above $25^\circ\text{C}$	$P_D$	31.8	W
		0.26	W/ $^\circ\text{C}$
Operating and Storage Temperature Range	$T_J, T_{STG}$	-55 to +150	$^\circ\text{C}$
Continuous diode forward current	$I_S$	11	A
Diode pulse current	$I_{S,pulse}$	30	A

**Thermal Characteristics TO-252/TO-220/ TO-262/ TO-263**

Parameter	Symbol	Value	Unit
Thermal Resistance, Junction-to-Case	$R_{\theta JC}$	1.39	$^{\circ}\text{C}/\text{W}$
Thermal Resistance, Junction-to-Ambient	$R_{\theta JA}$	45	$^{\circ}\text{C}/\text{W}$
Soldering temperature, wavesoldering only allowed at leads. (1.6mm from case for 10s)	$T_{\text{sold}}$	260	$^{\circ}\text{C}$

**Thermal Characteristics TO-220MF**

Parameter	Symbol	Value	Unit
Thermal Resistance, Junction-to-Case	$R_{\theta JC}$	3.9	$^{\circ}\text{C}/\text{W}$
Thermal Resistance, Junction-to-Ambient	$R_{\theta JA}$	53	$^{\circ}\text{C}/\text{W}$
Soldering temperature, wavesoldering only allowed at leads. (1.6mm from case for 10s)	$T_{\text{sold}}$	260	$^{\circ}\text{C}$

**Package Marking and Ordering Information**

Device	Device Package	Marking	Units/Tube	Units/Tube
LSC65R380HT	TO-220	LSD65R380HT	50	
LSD65R380HT	TO-220MF	LSD65R380HT	50	
LSE65R380HT	TO-263	LSE65R380HT	50	
LSF65R380HT	TO-262	LSF65R380HT	50	800
LSG65R380HT	TO-252	LSG65R380HT		2500

**Electrical Characteristics**  $T_c = 25^{\circ}\text{C}$  unless otherwise noted

Parameter	Symbol	Test Condition	Min.	Typ.	Max.	Unit
<b>Static characteristics</b>						
Drain-source breakdown voltage	$BV_{DSS}$	$V_{GS}=0\text{ V}, I_D=0.25\text{ mA}$	650	-	-	V
Gate threshold voltage	$V_{GS(th)}$	$V_{DS}=V_{GS}, I_D=0.25\text{ mA}$	2.5	3.5	4.5	V
Drain cut-off current	$I_{DSS}$	$V_{DS}=650\text{ V}, V_{GS}=0\text{ V},$ $T_j = 25^{\circ}\text{C}$ $T_j = 125^{\circ}\text{C}$	-	-	1	$\mu\text{A}$
Gate leakage current, Forward	$I_{GSSF}$	$V_{GS}=30\text{ V}, V_{DS}=0\text{ V}$	-	-	100	nA
Gate leakage current, Reverse	$I_{GSSR}$	$V_{GS}=-30\text{ V}, V_{DS}=0\text{ V}$	-	-	-100	nA
Drain-source on-state resistance	$R_{DS(on)}$	$V_{GS}=10\text{ V}, I_D=5.5\text{ A}$ $T_j = 25^{\circ}\text{C}$ $T_j = 150^{\circ}\text{C}$	-	0.33	0.38	$\Omega$
Gate resistance	$R_G$	$f=1\text{ MHz}, \text{open drain}$	-	5.7	-	$\Omega$
<b>Dynamic characteristics</b>						
Input capacitance	$C_{iss}$	$V_{DS} = 25\text{ V}, V_{GS} = 0\text{ V},$ $f = 1\text{ MHz}$	-	560	-	pF
Output capacitance	$C_{oss}$		-	216	-	
Reverse transfer capacitance	$C_{rss}$		-	1.2	-	
Turn-on delay time	$t_{d(on)}$	$V_{DD} = 400\text{ V}, I_D = 5.5\text{ A}$ $R_G = 10\Omega, V_{GS}=15\text{ V}$	-	20.6	-	ns
Rise time	$t_r$		-	32	-	
Turn-off delay time	$t_{d(off)}$		-	62	-	

Fall time	$t_f$		-	12.5	-	
<b>Gate charge characteristics</b>						
Gate to source charge	$Q_{gs}$	$V_{DD}=400\text{ V}, I_D=5.5\text{ A},$ $V_{GS}=0\text{ to }10\text{ V}$	-	4.8	-	nC
Gate to drain charge	$Q_{gd}$		-	4.7	-	
Gate charge total	$Q_g$		-	14.7	-	
Gate plateau voltage	$V_{plateau}$		-	6	-	V
<b>Reverse diode characteristics</b>						
Diode forward voltage	$V_{SD}$	$V_{GS}=0\text{ V}, I_F=5.5\text{ A}$	-	1.2	-	V
Reverse recovery time	$t_{rr}$	$V_R=400\text{ V}, I_F=5.5\text{ A},$ $di_F/dt=100\text{ A}/\mu\text{s}$	-	234	-	ns
Reverse recovery charge	$Q_{rr}$		-	4.4	-	$\mu\text{C}$
Peak reverse recovery current	$I_{rrm}$		-	18.7	-	A

**Notes:**

1. Limited by maximum junction temperature, maximum duty cycle is 0.75.
2.  $I_{AS} = 3\text{ A}, V_{DD} = 60\text{ V},$  Starting  $T_J = 25^\circ\text{C}.$
3. Repetitive Rating: Pulse width limited by maximum junction temperature.

## Electrical Characteristics Diagrams

Figure 1. On-Region Characteristics

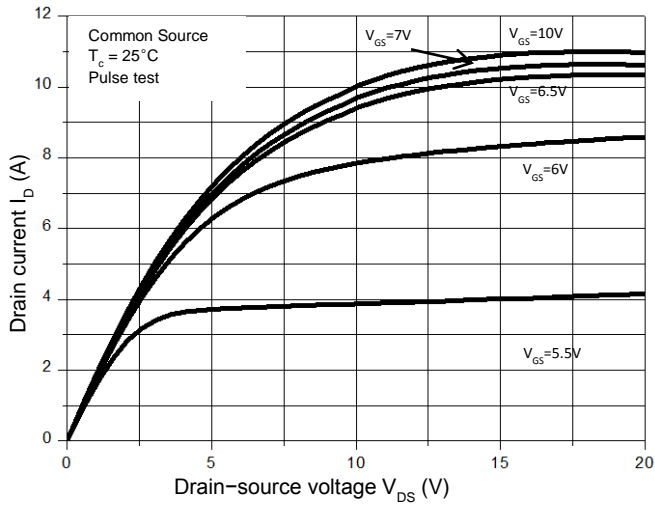

Figure 2. Transfer Characteristics

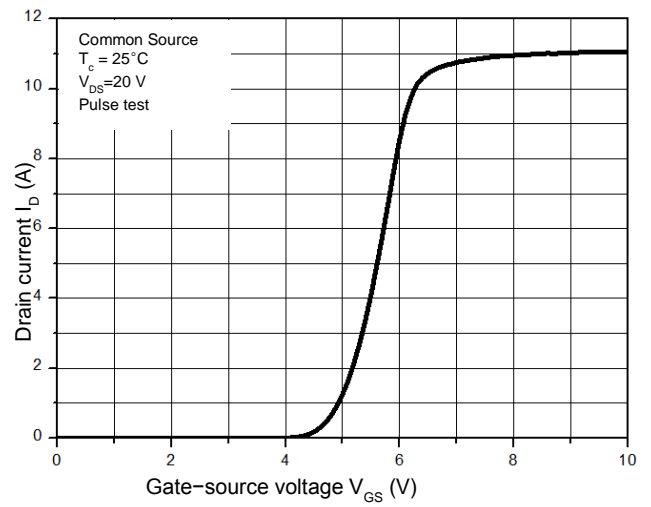

Figure 3. On-Resistance Variation vs. Drain Current

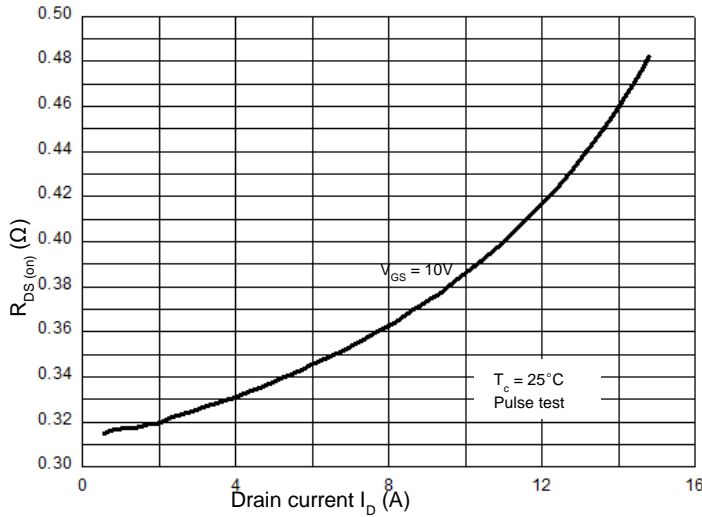

Figure 4. Threshold Voltage vs. Temperature

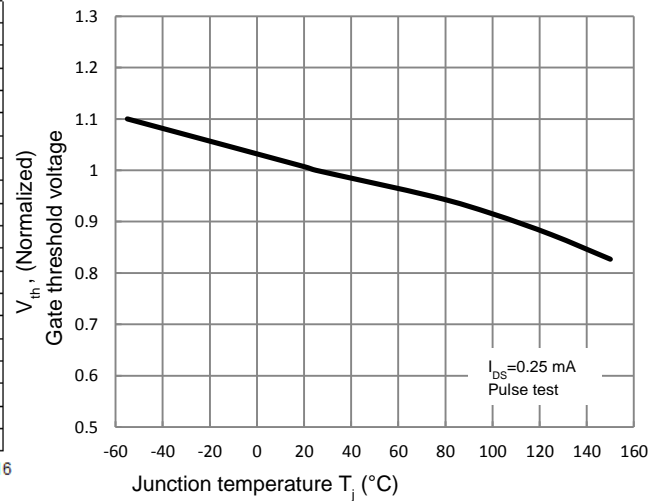

Figure 5. Breakdown Voltage vs. Temperature

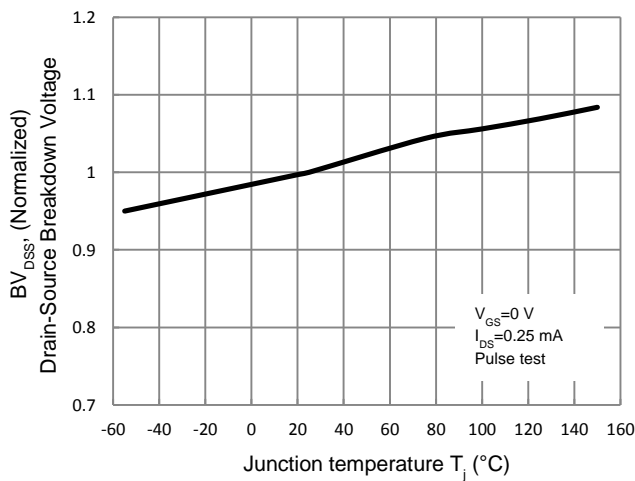

Figure 6. On-Resistance vs. Temperature

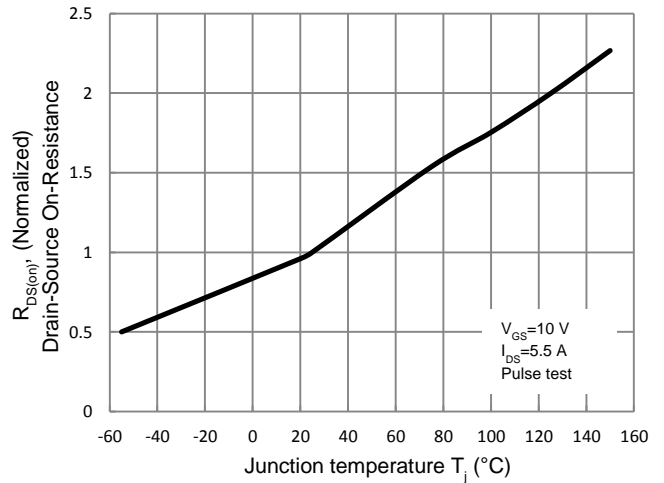

Figure 7. Capacitance Characteristics

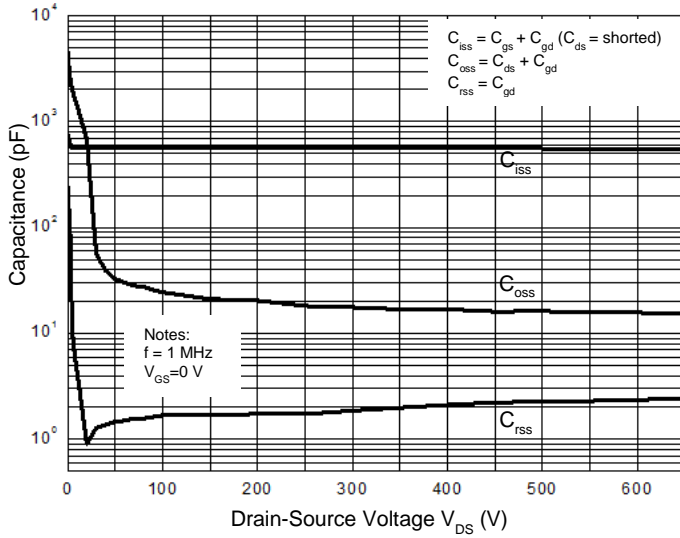

Figure 8. Gate Charge Characterist

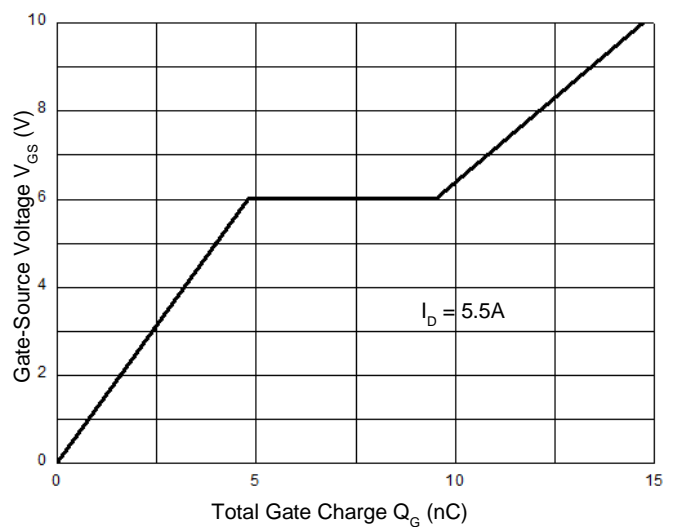

Figure 9.1 Maximum Safe Operating Area TO-220MF

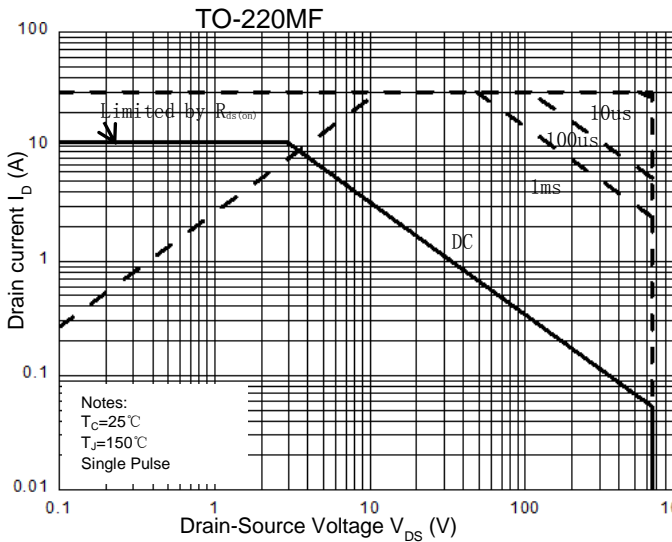

Figure 9.2 Maximum Safe Operating Area TO-220/TO-252/ TO-262/ TO-263

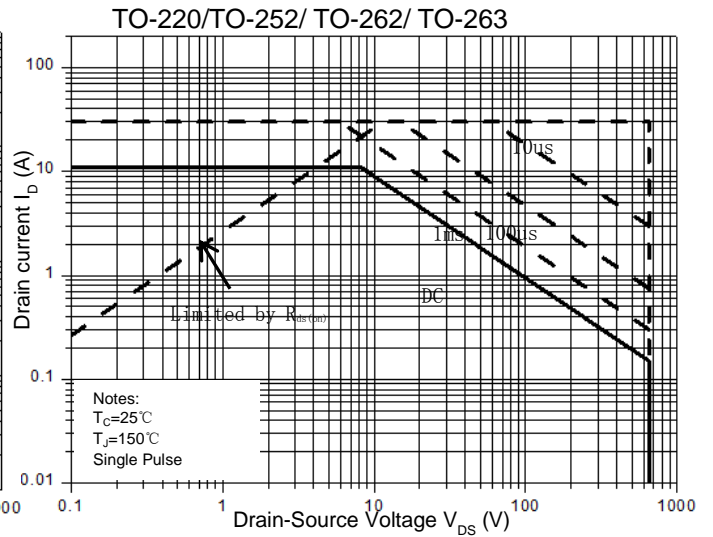

Figure 10.1 Power Dissipation vs. Temperature TO-220MF

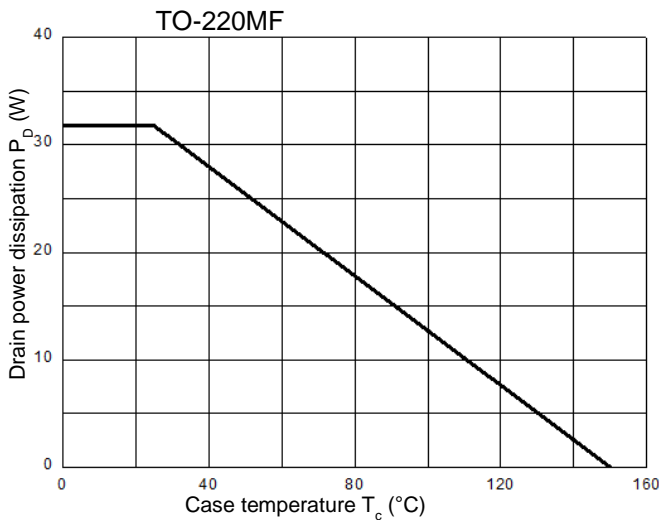
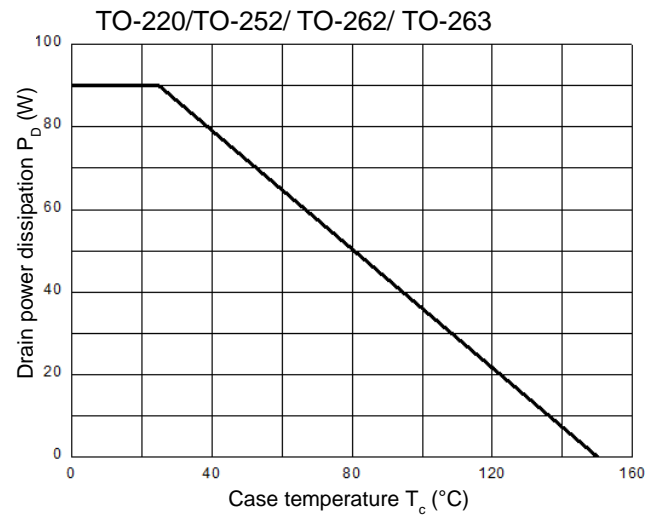
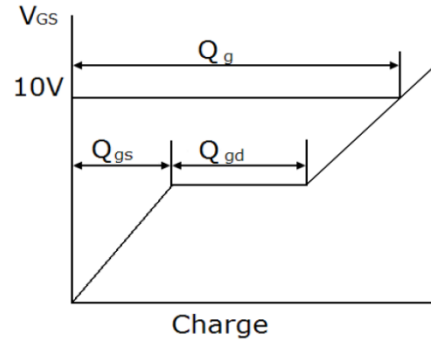
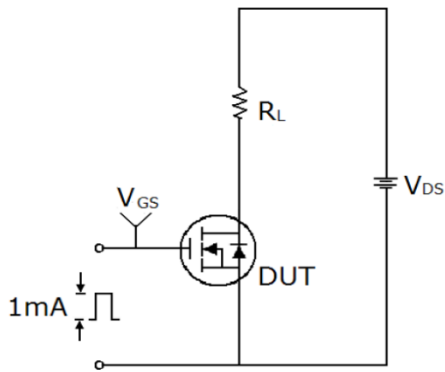

Figure 10.2 Power Dissipation vs. Temperature TO-220/TO-252/ TO-262/ TO-263



**Gate Charge Test Circuit & Waveform**



**Switching Test Circuit & Waveforms**

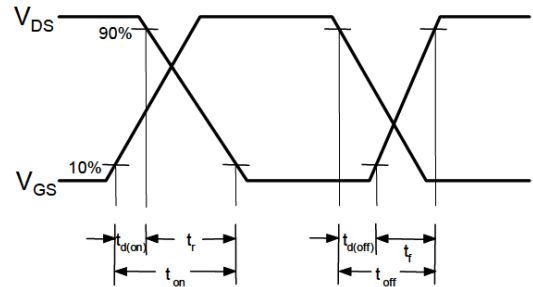
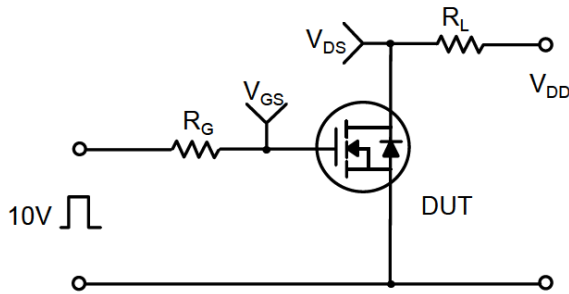

**Unclamped Inductive Switching Test Circuit & Waveforms**

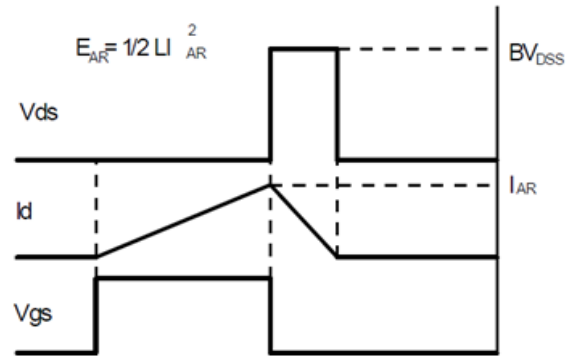
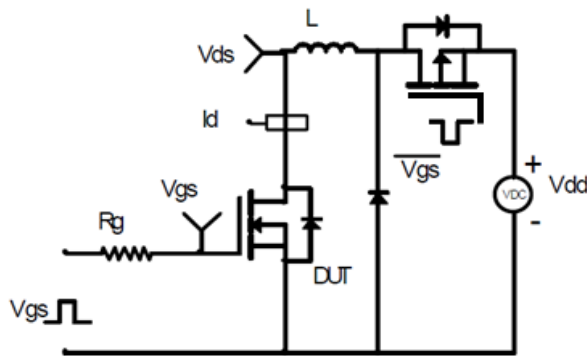

**Mechanical Dimensions for TO-220**

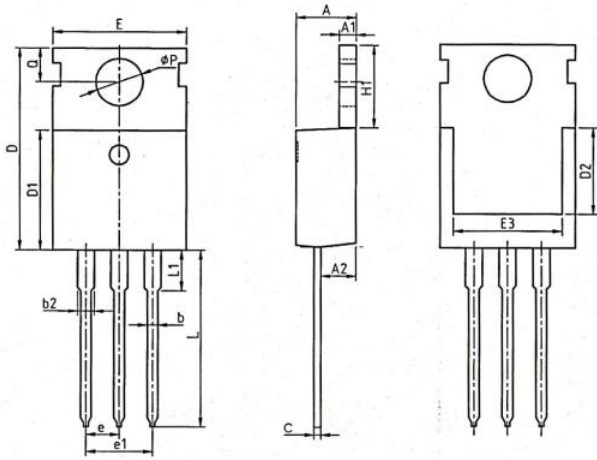

COMMON DIMENSIONS						
SYMBOL	MM			INCH		
	MIN	NOM	MAX	MIN	NOM	MAX
A	4.37	4.57	4.70	0.172	0.180	0.185
A1	1.25	1.30	1.40	0.049	0.051	0.055
A2	2.20	2.40	2.60	0.087	0.094	0.102
b	0.70	0.80	0.95	0.028	0.031	0.037
b2	1.17	1.27	1.47	0.046	0.050	0.058
c	0.45	0.50	0.60	0.018	0.020	0.024
D	15.10	15.60	16.10	0.594	0.614	0.634
D1	8.80	9.10	9.40	0.346	0.358	0.370
D2	5.50	—	—	0.217	—	—
E	9.70	10.00	10.30	0.382	0.394	0.406
E3	7.00	—	—	0.276	—	—
e	2.54BSC			0.1BSC		
e1	5.08BSC			0.2BSC		
H1	6.25	6.50	6.85	0.246	0.256	0.270
L	12.75	13.50	13.80	0.502	0.531	0.543
L1	—	3.10	3.40	—	0.122	0.134
Øp	3.40	3.60	3.80	0.134	0.142	0.150
Q	2.60	2.80	3.00	0.102	0.110	0.118

**TO-220 Part Marking Information**

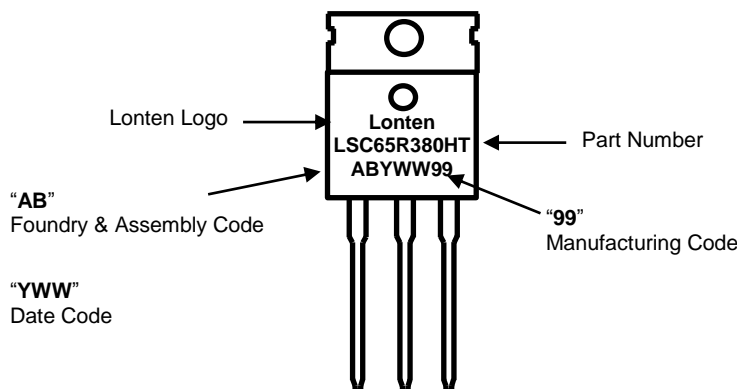

**Mechanical Dimensions for TO-220MF**

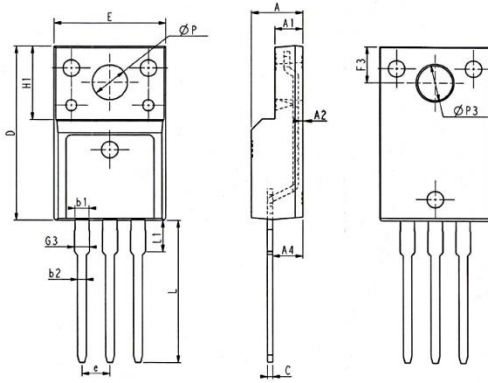

COMMON DIMENSIONS						
SYMBOL	MM			INCH		
	MIN	NOM	MAX	MIN	NOM	MAX
E	9.96	10.16	10.36	0.392	0.400	0.408
A	4.50	4.70	4.90	0.177	0.185	0.193
A1	2.34	2.54	2.74	0.092	0.100	0.108
A2	0.30	0.45	0.60	0.012	0.002	0.024
A4	2.65	2.76	2.96	0.104	0.109	0.117
C	0.40	0.50	0.38	0.016	0.020	0.026
D	15.57	15.87	16.17	0.613	0.625	0.637
H1	6.70REF			0.264REF		
e	2.54BSC			0.1BSC		
ØP	3.03	3.18	3.38	0.119	0.125	0.133
L	12.68	12.98	13.28	0.499	0.511	0.523
L1	2.88	3.03	3.18	0.113	0.119	0.125
ØP3	3.15REF			0.124REF		
F3	3.15	3.30	3.45	0.124	0.130	0.136
G3	1.25	1.35	1.55	0.049	0.053	0.061
b1	1.18	1.28	1.43	0.046	0.050	0.056
b2	0.70	0.80	0.95	0.028	0.031	0.037

**TO-220MF Part Marking Information**

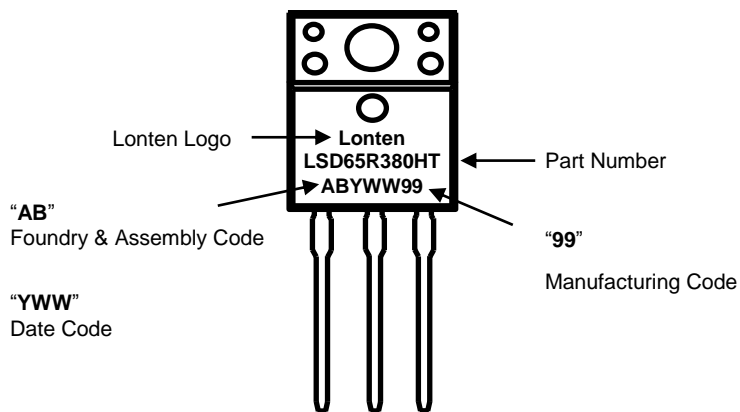



**Mechanical Dimensions for TO-252**

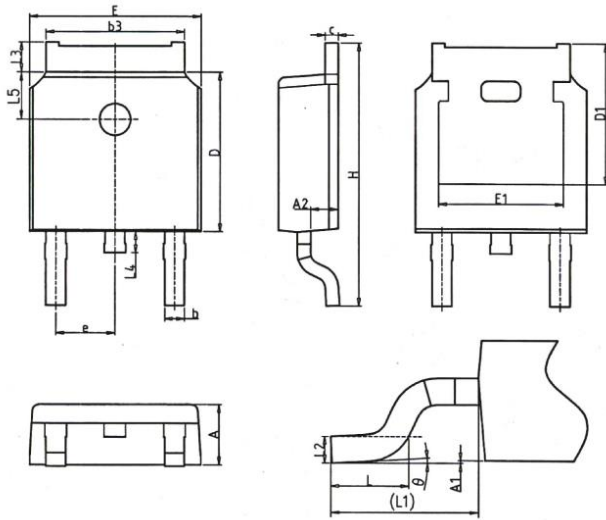

COMMON DIMENSIONS			
SYMBOL	mm		
	MIN	NOM	MAX
A	2.20	2.30	2.38
A1	0.00	—	0.20
A2	0.97	1.07	1.17
b	0.68	0.78	0.90
b3	5.20	5.33	5.46
c	0.43	0.53	0.61
D	5.98	6.10	6.22
D1	5.30REF		
E	6.40	6.60	6.73
E1	4.63	—	—
e	2.286BSC		
H	9.40	10.10	10.50
L	1.38	1.50	1.75
L1	2.90REF		
L2	0.51BSC		
L3	0.88	—	1.28
L4	0.50	—	1.00
L5	1.65	1.80	1.95
θ	0°	—	8°

**TO-252 Part Marking Information**

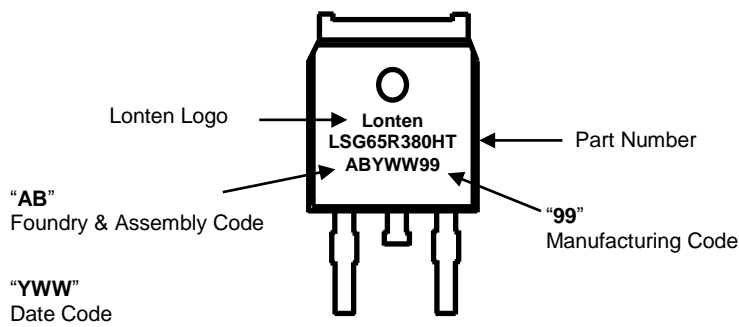

**Mechanical Dimensions for TO-263**

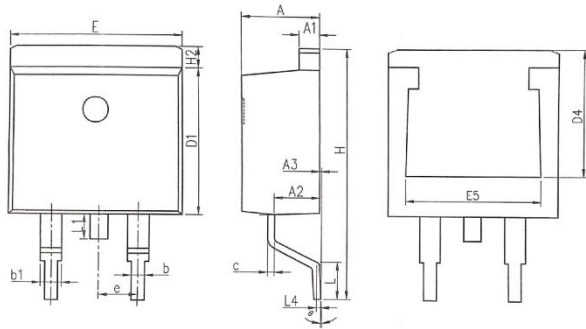

COMMON DIMENSIONS						
SYMBOL	MM			INCH		
	MIN	NOM	MAX	MIN	NOM	MAX
A	4.37	4.57	4.77	0.172	0.180	0.188
A1	1.22	1.27	1.42	0.048	0.050	0.056
A2	2.49	2.89	2.89	0.098	0.114	0.114
A3	0.00	0.13	0.25	0.000	0.005	0.010
b	0.70	0.81	0.96	0.028	0.032	0.034
b1	1.17	1.27	1.47	0.046	0.050	0.058
c	0.30	0.38	0.53	0.012	0.015	0.021
D1	8.50	8.70	8.90	0.335	0.343	0.350
D4	6.60	—	—	0.260	—	—
E	9.86	10.16	10.36	0.389	0.400	0.408
E5	7.06	—	—	0.278	—	—
e	2.54 BSC			0.100 BSC		
H	14.70	15.10	15.50	0.579	0.594	0.610
H2	1.07	1.27	1.47	0.042	0.050	0.058
L	2.00	2.30	2.60	0.079	0.091	0.102
L1	1.40	1.55	1.70	0.055	0.061	0.067
L4	0.25 BSC			0.010 BSC		
θ	0°	5°	9°	0°	0.197°	0.354°

**TO-263 Part Marking Information**

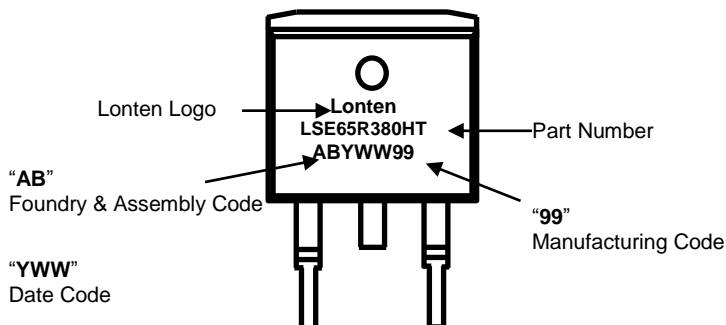

**Mechanical Dimensions for TO-262**

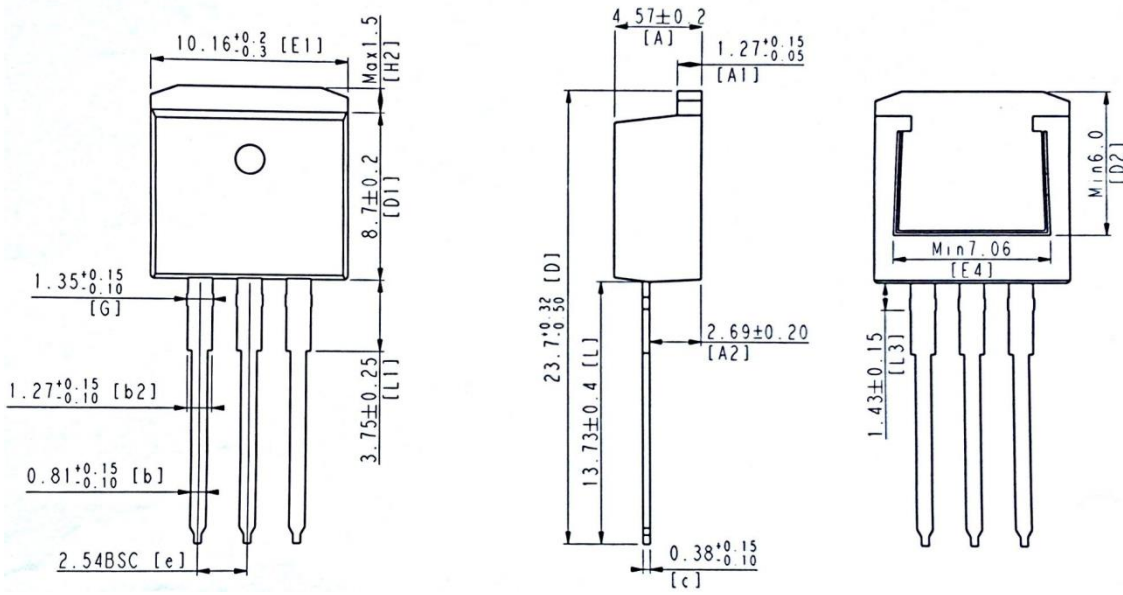

**TO-262 Part Marking Information**

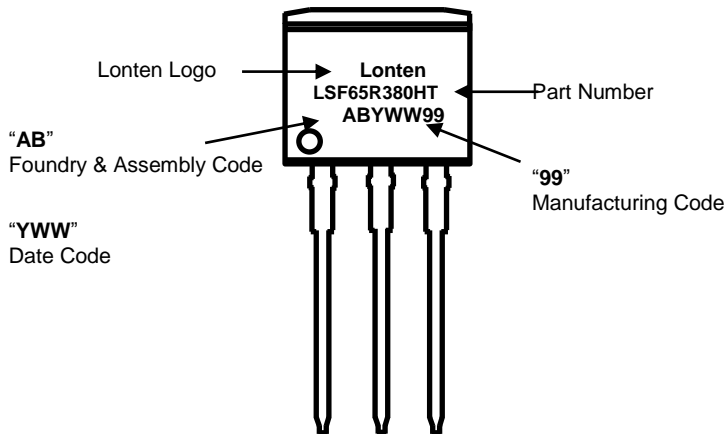

## Disclaimer

The content specified herein is for the purpose of introducing LONTEN's products (hereinafter "Products"). The information given in this document shall in no event be regarded as a guarantee of conditions or characteristics. Examples of application circuits, circuit constants and any other information contained herein illustrate the standard usage and operations of the Products. The peripheral conditions must be taken into account when designing circuits for mass production.

LONTEN does not assume any liability for infringement of patents, copyrights, or other intellectual property rights of third parties by or arising from the use of the Products or technical information described in this document.

The Products are not designed or manufactured to be used with any equipment, device or system which requires an extremely high level of reliability the failure or malfunction of which may result in a direct threat to human life or create a risk of human injury (such as a medical instrument, transportation equipment, aerospace machinery, nuclear-reactor controller, fuel-controller or other safety device). LONTEN shall bear no responsibility in any way for use of any of the Products for the above special purposes.

Although LONTEN endeavors to improve the quality and reliability of its products, semiconductor products have specific characteristics such as the occurrence of failure at a certain rate and malfunctions under certain use conditions. Please be sure to implement safety measures to guard them against the possibility of physical injury, and injury or damage caused by fire in the event of the failure of a LONTEN product.

The content specified herein is subject to change for improvement without notice. When using a LONTEN product, be sure to obtain the latest specifications.

Oct. 2018 Revision 1.0