





Lonten N-channel 650V, 12A Power MOSFET

<p>Description The Power MOSFET is fabricated using the advanced planer VDMOS technology. The resulting device has low conduction resistance, superior switching performance and high avalanche energy.</p> <p>Features</p> <ul style="list-style-type: none"> ◆ Low $R_{DS(on)}$ ◆ Low gate charge (typ. $Q_g = 41.9$ nC) ◆ 100% UIS tested ◆ RoHS compliant <p>Applications</p> <ul style="list-style-type: none"> ◆ Power factor correction. ◆ Switched mode power supplies. ◆ LED driver. 	<p>Product Summary</p> <table> <tr> <td>V_{DSS}</td> <td>650V</td> </tr> <tr> <td>I_D</td> <td>12A</td> </tr> <tr> <td>$R_{DS(on),max}$</td> <td>0.8Ω</td> </tr> <tr> <td>$Q_{g,typ}$</td> <td>41.9 nC</td> </tr> </table> <div style="display: flex; justify-content: space-around; align-items: center;"> <div style="text-align: center;">  TO-262 </div> <div style="text-align: center;">  TO-263 </div> <div style="text-align: center;">  TO-220 </div> <div style="text-align: center;">  TO-220F </div> </div> <div style="text-align: center; margin-top: 20px;">  N-Channel MOSFET </div> <div style="text-align: right; margin-top: 10px;">  </div>	V_{DSS}	650V	I_D	12A	$R_{DS(on),max}$	0.8 Ω	$Q_{g,typ}$	41.9 nC
V_{DSS}	650V								
I_D	12A								
$R_{DS(on),max}$	0.8 Ω								
$Q_{g,typ}$	41.9 nC								

Absolute Maximum Ratings

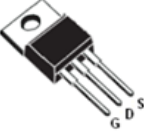
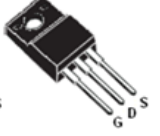
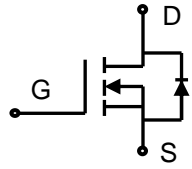
Parameter	Symbol	Value	Unit
Drain-Source Voltage	V_{DSS}	650	V
Continuous drain current ($T_C = 25^\circ\text{C}$)	I_D	12	A
($T_C = 100^\circ\text{C}$)		7.5	A
Pulsed drain current ¹⁾	I_{DM}	48	A
Gate-Source voltage	V_{GSS}	± 30	V
Avalanche energy, single pulse ²⁾	E_{AS}	500	mJ
Peak diode recovery dv/dt ³⁾	dv/dt	5	V/ns
Power Dissipation TO-220F ($T_C = 25^\circ\text{C}$)	P_D	42	W
Derate above 25°C		0.34	W/°C
Power Dissipation TO-220\ TO-262\ TO-263 ($T_C = 25^\circ\text{C}$)	P_D	150	W
Derate above 25°C		1.2	W/°C
Operating junction and storage temperature range	T_J, T_{STG}	-55 to +150	°C
Continuous diode forward current	I_S	12	A
Diode pulse current	$I_{S,pulse}$	48	A

Thermal Characteristics

Parameter	Symbol	Value		Unit
		TO-220F	TO-220\TO-251\TO-252	
Thermal resistance, Junction-to-case	$R_{\theta JC}$	2.98	0.83	°C/W
Thermal resistance, Junction-to-ambient	$R_{\theta JA}$	110	62.5	°C/W

Package Marking and Ordering Information

Device	Device Package	Marking	Units/Tube	Units/Real
LNC12N65	TO-220	LNC12N65	50	
LND12N65	TO-220F	LND12N65	50	
LNE12N65	TO-263	LNE12N65	50	
LNF12N65	TO-262	LNF12N65	50	

Electrical Characteristics $T_c = 25^\circ\text{C}$ unless otherwise noted

Parameter	Symbol	Test Condition	Min.	Typ.	Max.	Unit
Static characteristics						
Drain-source breakdown voltage	BV_{DSS}	$V_{GS}=0\text{ V}, I_D=0.25\text{ mA}$	650	-	-	V
Gate threshold voltage	$V_{GS(th)}$	$V_{DS}=V_{GS}, I_D=0.25\text{ mA}$	2	-	4	V
Drain cut-off current	I_{DSS}	$V_{DS}=650\text{ V}, V_{GS}=0\text{ V},$ $T_j = 25^\circ\text{C}$ $T_j = 125^\circ\text{C}$	-	-	1	μA
Gate leakage current, Forward	I_{GSSF}	$V_{GS}=30\text{ V}, V_{DS}=0\text{ V}$	-	-	100	nA
Gate leakage current, Reverse	I_{GSSR}	$V_{GS}=-30\text{ V}, V_{DS}=0\text{ V}$	-	-	-100	nA
Drain-source on-state resistance	$R_{DS(on)}$	$V_{GS}=10\text{ V}, I_D=6\text{ A}$	-	0.64	0.8	Ω
Dynamic characteristics						
Input capacitance	C_{iss}	$V_{DS} = 25\text{ V}, V_{GS} = 0\text{ V},$ $f = 1\text{ MHz}$	-	2000	-	pF
Output capacitance	C_{oss}		-	164	-	
Reverse transfer capacitance	C_{rss}		-	7.4	-	
Turn-on delay time	$t_{d(on)}$	$V_{DD} = 325\text{ V}, I_D = 12\text{ A}$ $R_G = 10\ \Omega, V_{GS}=15\text{ V}$	-	14.6	-	ns
Rise time	t_r		-	37.8	-	
Turn-off delay time	$t_{d(off)}$		-	69.3	-	
Fall time	t_f		-	15.8	-	
Gate charge characteristics						
Gate to source charge	Q_{gs}	$V_{DD}=520\text{ V}, I_D=12\text{ A},$ $V_{GS}=0\text{ to }10\text{ V}$	-	10.8	-	nC
Gate to drain charge	Q_{gd}		-	15	-	
Gate charge total	Q_g		-	41.9	-	
Gate plateau voltage	$V_{plateau}$		-	5	-	V
Reverse diode characteristics						
Diode forward voltage	V_{SD}	$V_{GS}=0\text{ V}, I_F=12\text{ A}$	-	-	1.5	V
Reverse recovery time	t_{rr}	$V_R=325\text{ V}, I_F=12\text{ A},$ $di_F/dt=100\text{ A}/\mu\text{s}$	-	450.4	-	ns
Reverse recovery charge	Q_{rr}		-	4.75	-	μC
Peak reverse recovery current	I_{rrm}		-	21.1	-	A

Notes:

- Pulse width limited by maximum junction temperature.
- $L=10\text{mH}, I_{AS} = 10\text{A},$ Starting $T_j= 25^\circ\text{C}.$
- $I_{SD} = 12\text{A}, di/dt \leq 100\text{A}/\mu\text{s}, V_{DD} \leq BV_{DS},$ Starting $T_j= 25^\circ\text{C}.$

Electrical Characteristics Diagrams

Figure 1. Typical Output Characteristics

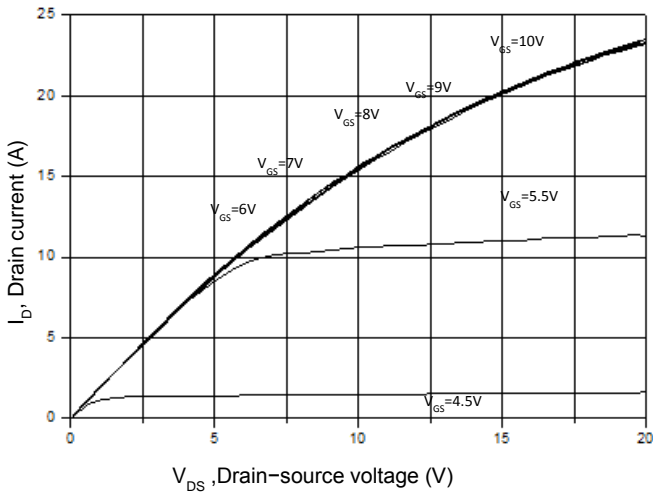

Figure 2. Transfer Characteristics

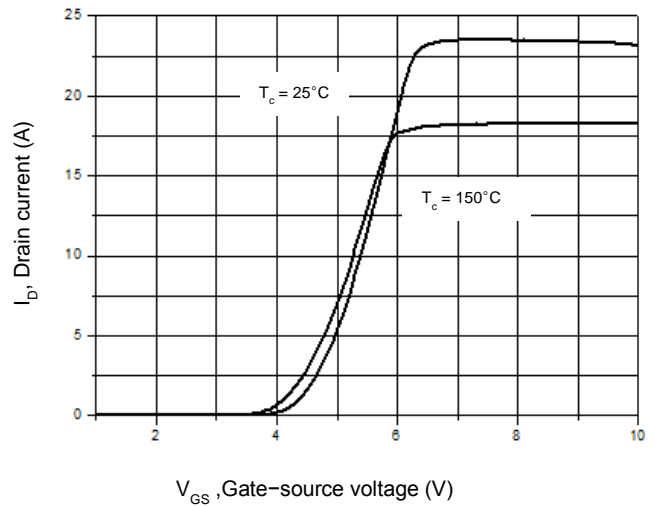

Figure 3. On-Resistance Variation vs. Drain Current

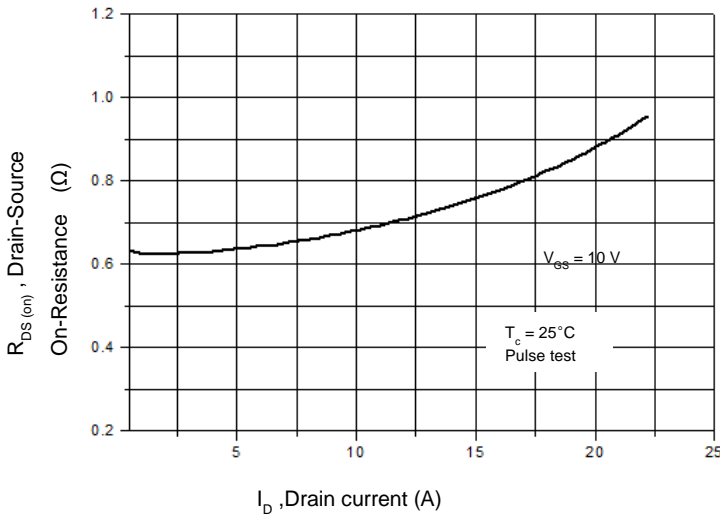

Figure 4. Threshold Voltage vs. Temperature

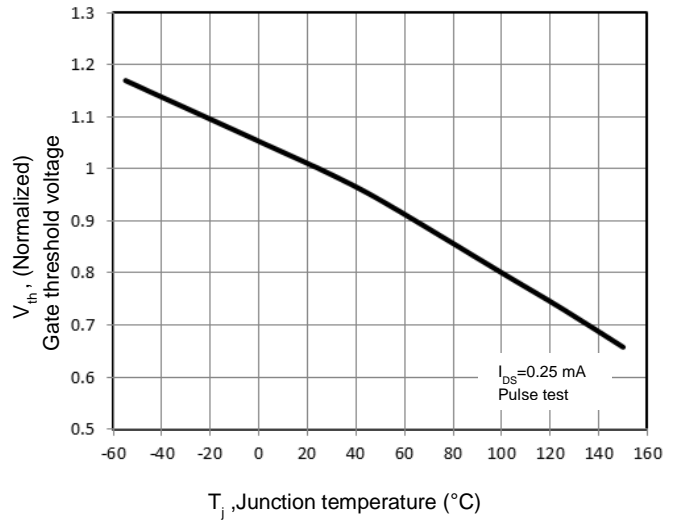

Figure 5. Breakdown Voltage vs. Temperature

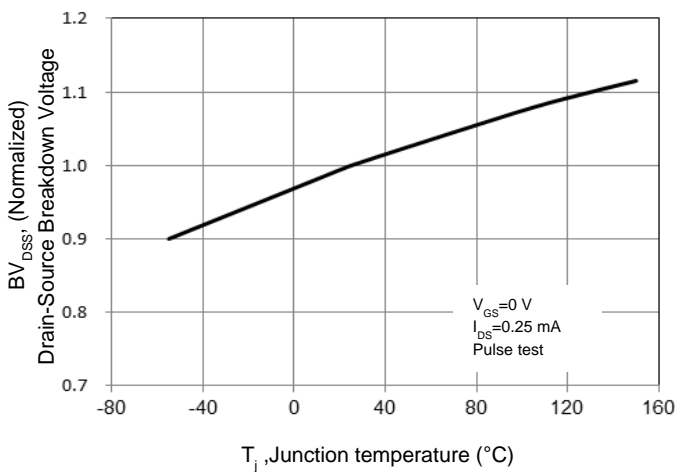

Figure 6. On-Resistance vs. Temperature

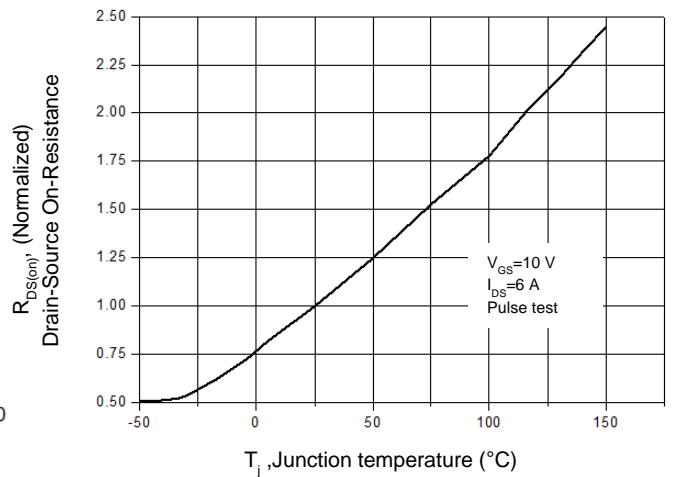

Figure 7. Capacitance Characteristics

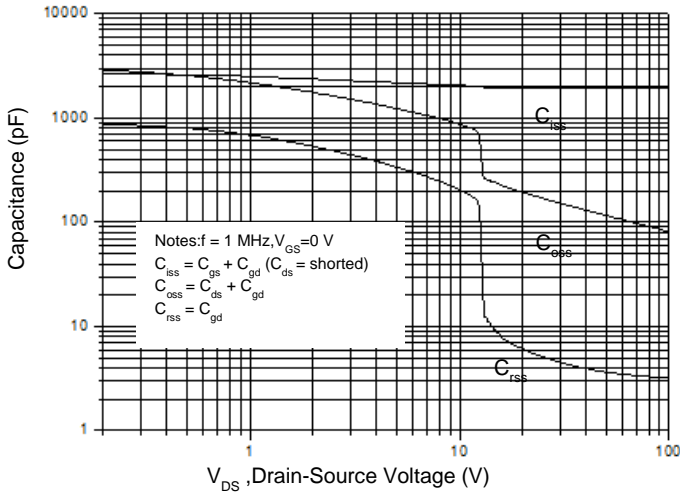

Figure 9. Maximum Safe Operating Area
TO-220F

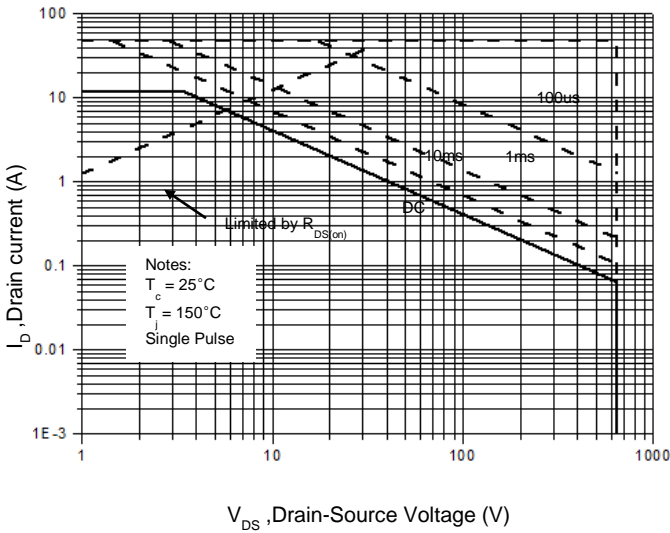

Figure 11. Power Dissipation vs. Temperature
TO-220F

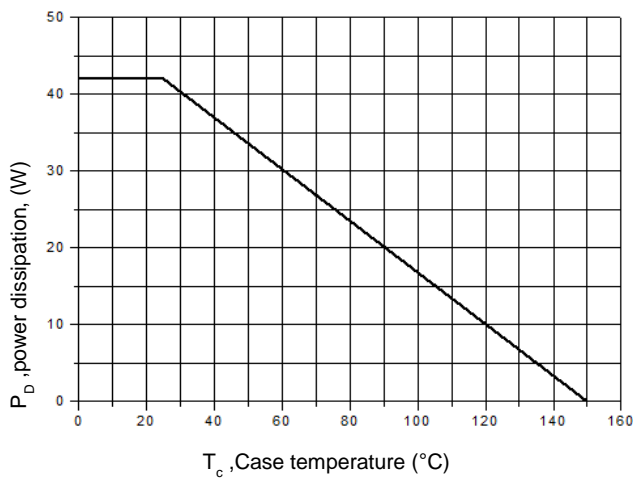

Figure 8. Gate Charge Characteristics

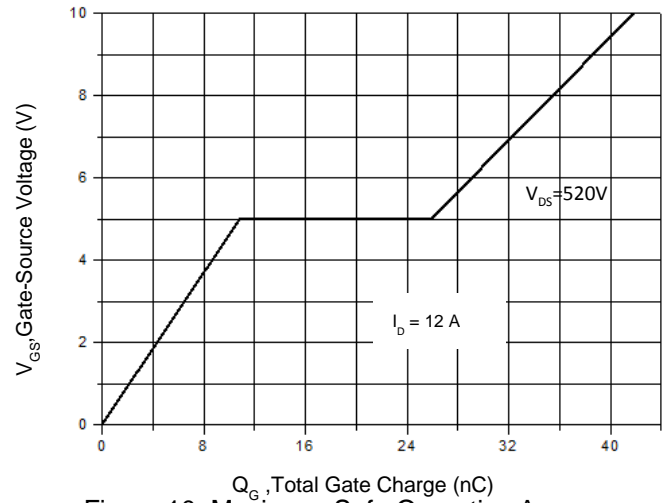

Figure 10. Maximum Safe Operating Area
TO-220/ TO-262/TO-263

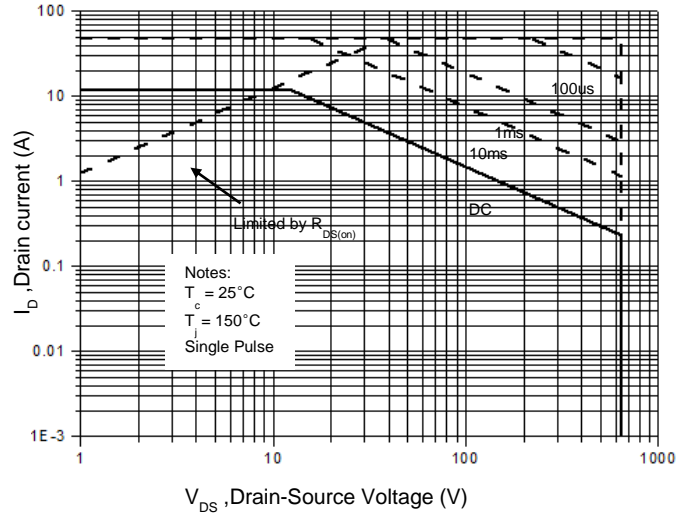

Figure 12. Power Dissipation vs. Temperature
TO-220/ TO-262/TO-263

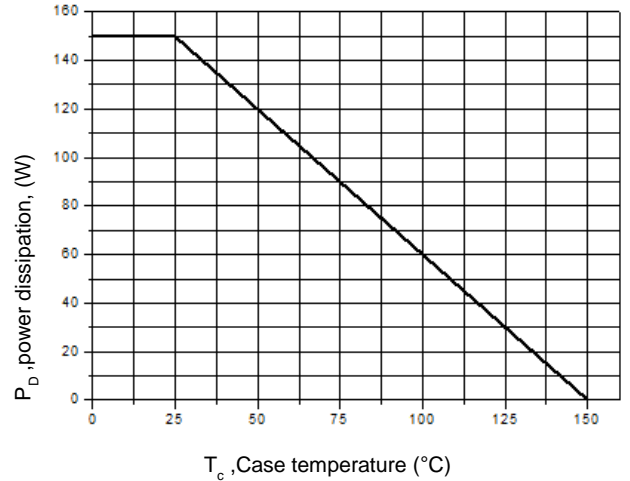

Figure 13. Continuous Drain Current vs. Temperature

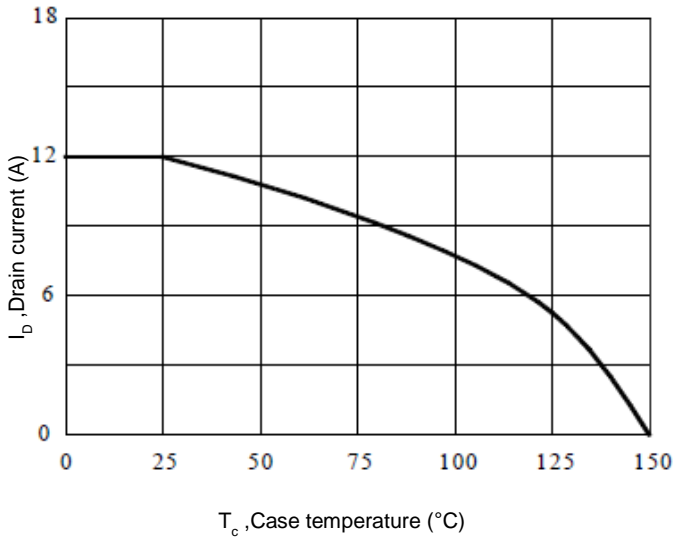

Figure 14. Body Diode Transfer Characteristics

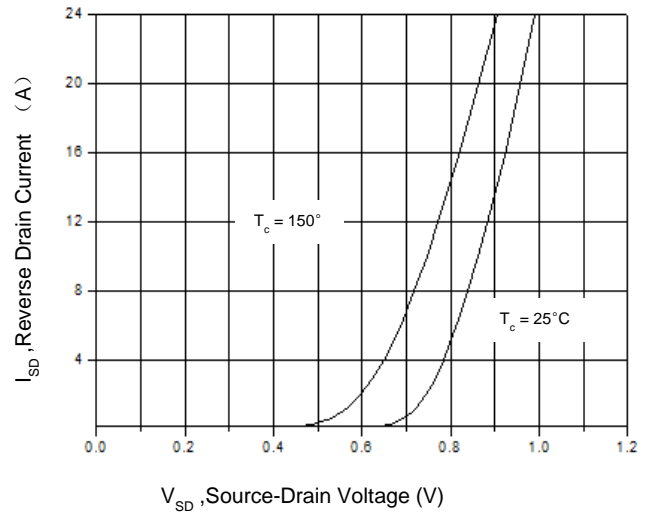

Figure 15 Transient Thermal Impedance, Junction to Case, TO-220F

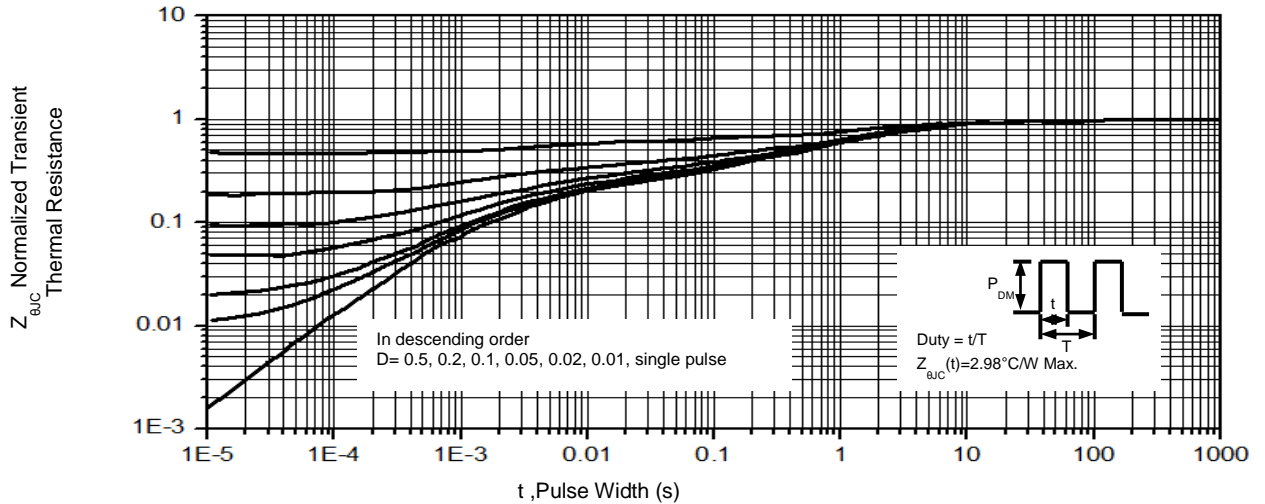
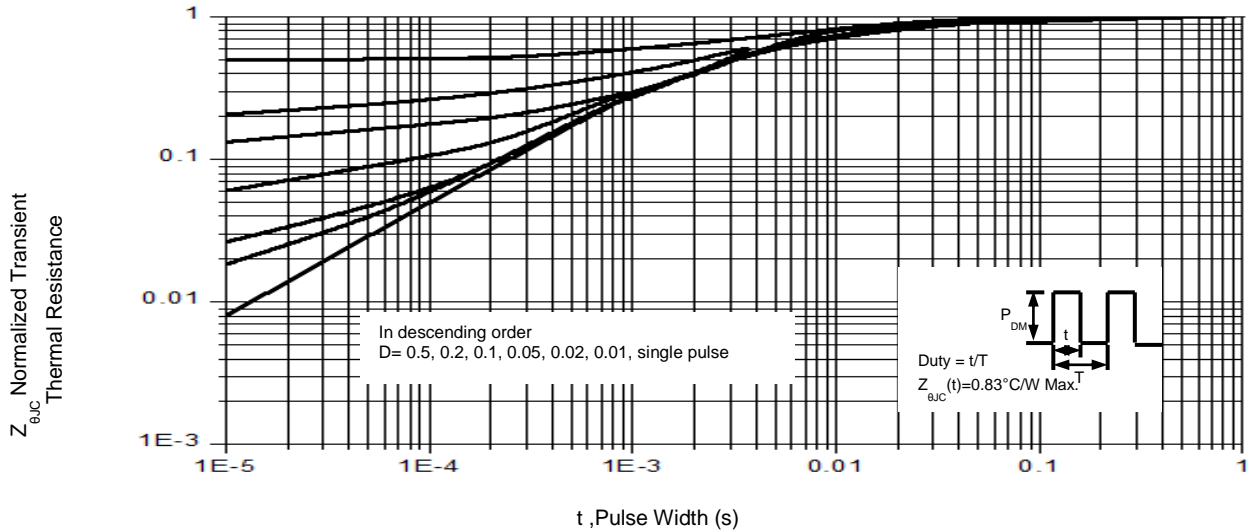
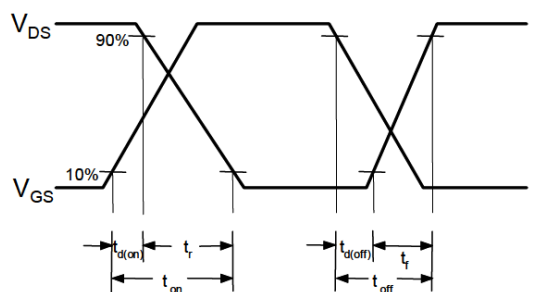
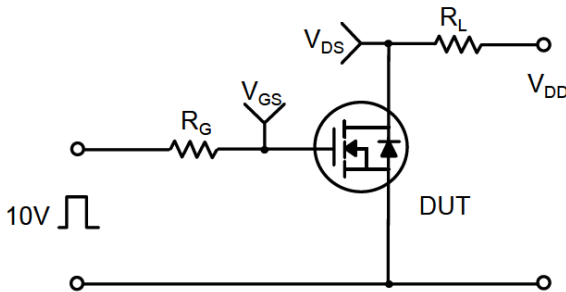

Figure 16. Transient Thermal Impedance, Junction to Case, TO-220/ TO-262/TO-263



Gate Charge Test Circuit & Waveform



Unclamped Inductive Switching Test Circuit & Waveforms



Mechanical Dimensions for TO-220



UNIT: mm

SYMBOL	MIN	NOM	MAX
A	4		4.8
B	1.2		1.4
B1	1		1.4
b1	0.75		0.95
c	0.4		0.55
D	15		16.5
D1	5.9		6.9
E	9.9		10.7
e	2.44	2.54	2.64
F	1.1		1.4
L	12.5		14.5
L1	3	3.5	4
ΦP	3.7	3.8	3.9
Q	2.5		3
Q1	2		2.9
Y	8.02	8.12	8.22

TO-220 Part Marking Information

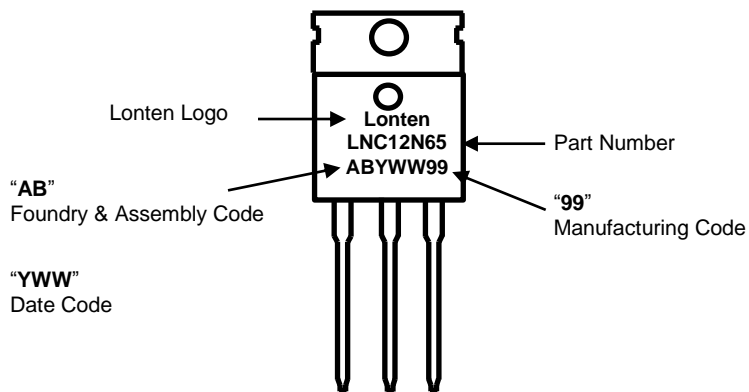

Mechanical Dimensions for TO-220F

UNIT: mm

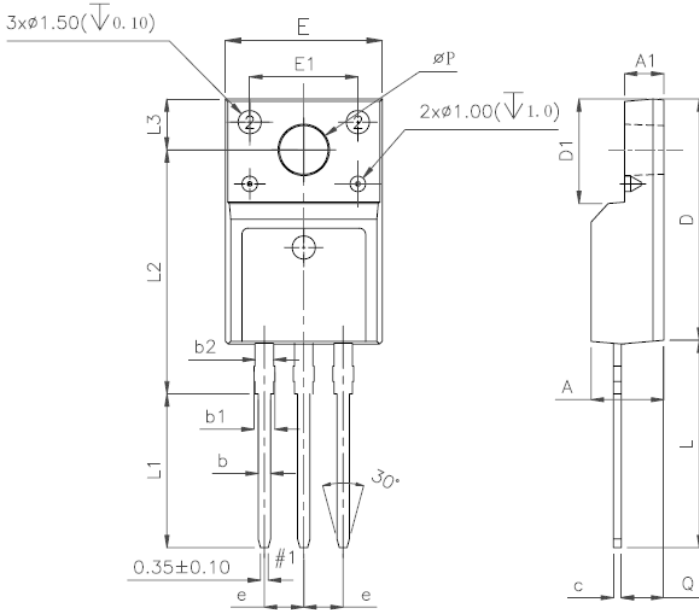

SYMBOL	MIN	NOM	MAX
A	4.5		4.9
A1	2.3		2.9
b	0.65		0.9
b1	1.1		1.7
b2	1.2		1.4
c	0.35		0.65
D	14.5		16.5
D1	6.1		6.9
E	9.6		10.3
E1	6.5	7	7.5
e	2.44	2.54	2.64
L	12.5		14.3
L1	9.45		10.05
L2	15		16
L3	3.2		4.4
∅P	3		3.3
Q	2.5		2.9

TO-220F Part Marking Information

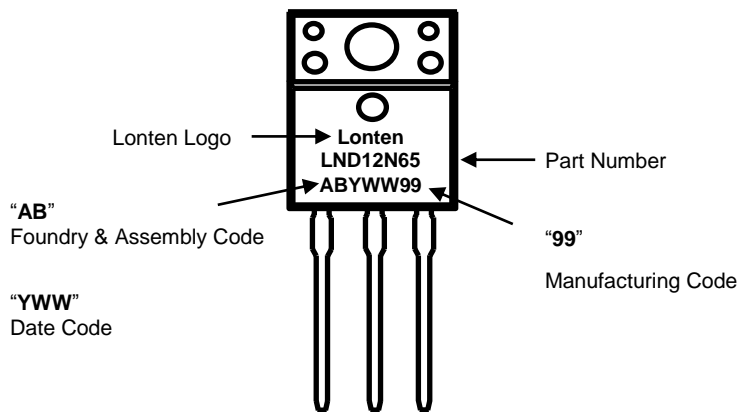

Mechanical Dimensions for TO-262

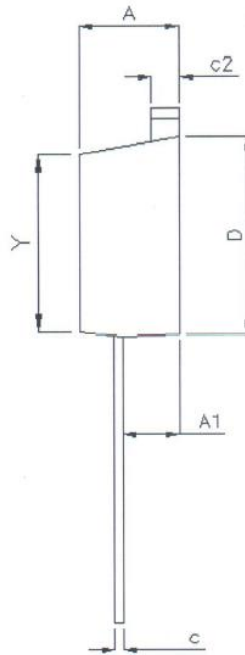
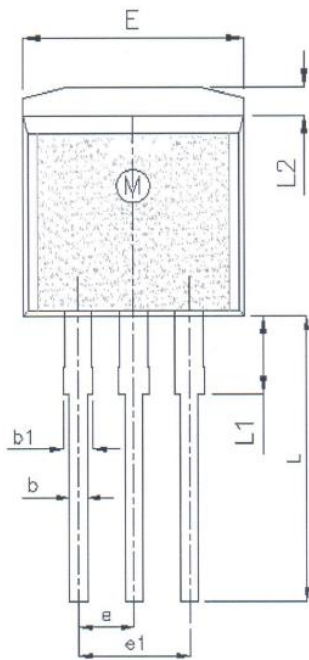

UNIT: mm

SYMBOL	MIN	NOM	MAX
A	4.42		4.72
A1	2.40		2.80
b	0.76		0.86
b1	1.22		1.40
c	0.33		0.43
c2	1.22		1.35
D	8.99		9.29
e	2.44	2.54	2.64
e1	4.98		5.18
E	9.95		10.25
L	12.50		13.60
L1	3.30	3.50	3.80
L2	1.22		1.40
Y	8.02	8.12	8.22

TO-262 Part Marking Information

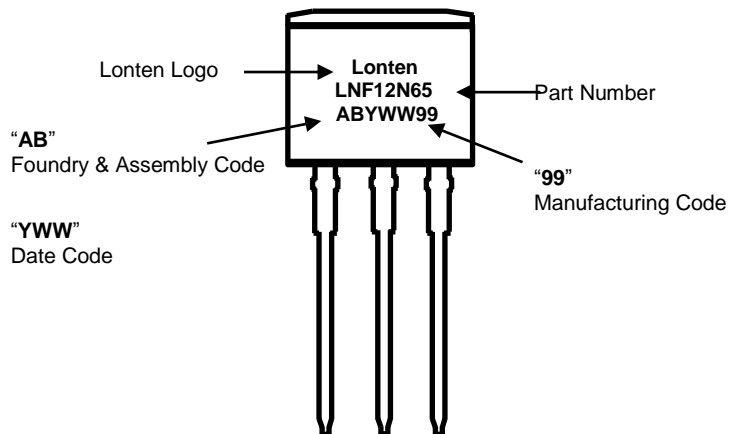

Mechanical Dimensions for TO-263

UNIT: mm

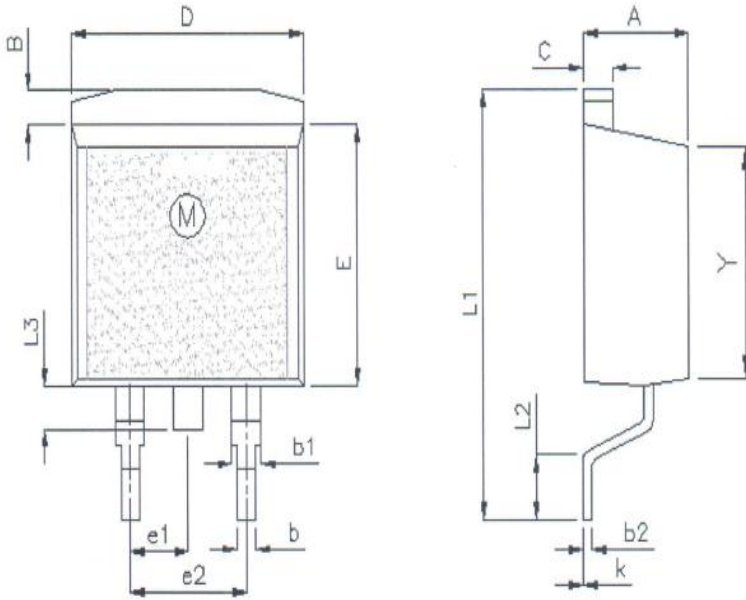

SYMBOL	MIN	NOM	MAX
A	4.42		4.72
B	1.22		1.4
b	0.76		0.86
b1	1.22		1.4
b2	0.33		0.43
C	1.22		1.35
D	9.95		10.25
E	8.99		9.29
e1	2.44	2.54	2.64
e2	4.98		5.18
L1	14.7	15.1	15.5
L2	2	2.3	2.6
L3	1.5		2
K	-0.1		0.1
Y	8.02	8.12	8.22

TO-263 Part Marking Information

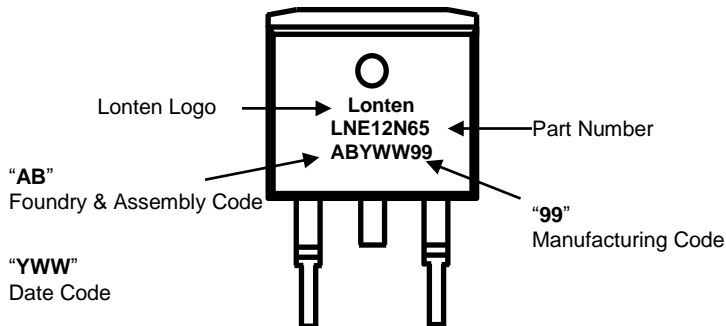

Disclaimer

The content specified herein is for the purpose of introducing LONTEN's products (hereinafter "Products"). The information given in this document shall in no event be regarded as a guarantee of conditions or characteristics. Examples of application circuits, circuit constants and any other information contained herein illustrate the standard usage and operations of the Products. The peripheral conditions must be taken into account when designing circuits for mass production.

LONTEN does not assume any liability for infringement of patents, copyrights, or other intellectual property rights of third parties by or arising from the use of the Products or technical information described in this document.

The Products are not designed or manufactured to be used with any equipment, device or system which requires an extremely high level of reliability the failure or malfunction of which may result in a direct threat to human life or create a risk of human injury (such as a medical instrument, transportation equipment, aerospace machinery, nuclear-reactor controller, fuel-controller or other safety device). LONTEN shall bear no responsibility in any way for use of any of the Products for the above special purposes.

Although LONTEN endeavors to improve the quality and reliability of its products, semiconductor products have specific characteristics such as the occurrence of failure at a certain rate and malfunctions under certain use conditions. Please be sure to implement safety measures to guard them against the possibility of physical injury, and injury or damage caused by fire in the event of the failure of a LONTEN product.

The content specified herein is subject to change for improvement without notice. When using a LONTEN product, be sure to obtain the latest specifications.