

AUTOCAD GENERATED DRAWING. DON'T CHANGE BY HAND.

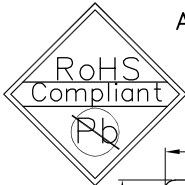

REV.	ECN NO.	DESCRIPTION	DRAW	APPD.	DATE
B	ECN1610190018	依业务要求新增DIP脚长度规格	潘鉴阳	谭军明	2016.10.19
C	ECN1705180023	修改电镀料号由半金雾锡改为全金	陈胜大	谭军明	2017.05.18
D	ECN1807020002	修改产品料号	陈胜大	王涛	2018.07.02
E	ECN1901020003	定位柱间距由7.35改为7.20	闵文	吴梅	2019.01.03

NOTES:  
 SPECIFICATION:  
 1. CURRENT RATING: 3.0A MAX  
 2. VOLTAGE: 100 VAC  
 3. TEMPERATURE RANGE: -30 °C ~ 85 °C  
 4. CONTACT RESISTANCE: 40 MILLIONHM MAX  
 5. INSULATION RESISTANCE: 100 MEGOHMS MIN.  
 6. INSERTION FORCE : 5N~20N  
 7. UNMATING FORCE: 8N~20N8N~20N(INITIAL)  
 6N~20N(AFTER DURATION)  
 8. DURABILITY: 10,000 CYCLES

A

A

B

B

C

C

D

D

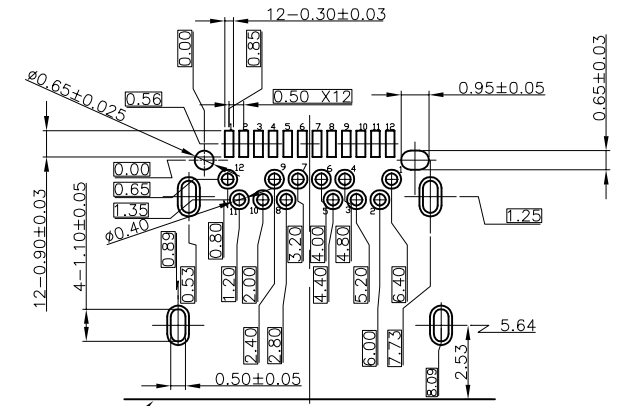
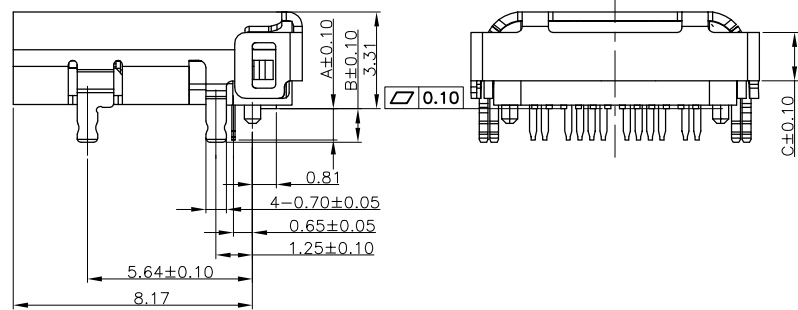
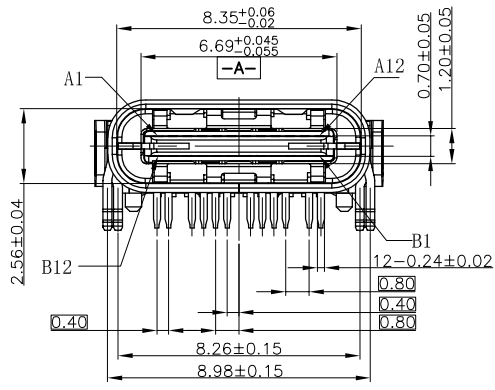
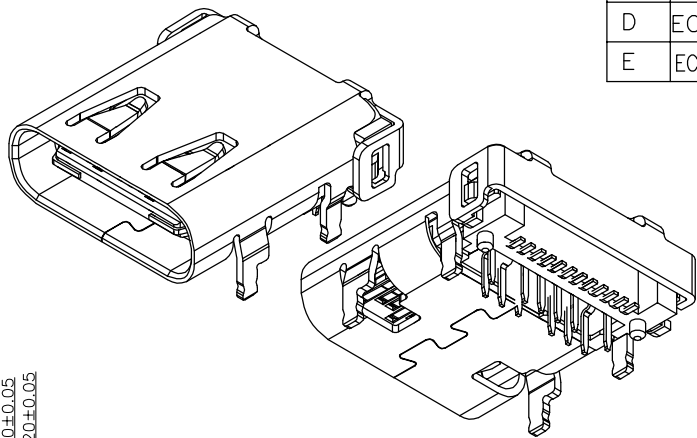
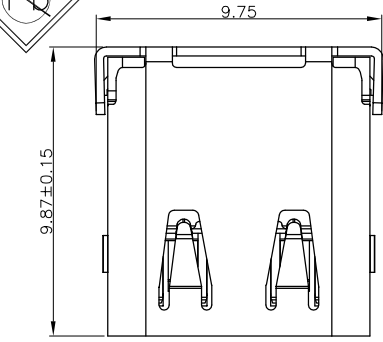

CONNECTOR FRONT EDGE  
 RECOMMENDED P.C.B. LAYOUT (T:1.00mm)  
 TOLERANCE UNSPECIFIED ±0.05mm

序号	成品料号	规格	DIM.A	DIM.B	DIM.C
1	CNG013S220R-WW	Au 1U", SOLDER AREA:GOLD FLASH(单边刷金)	1.10	1.15	1.26
2	CNG013S160R-WW	Au 15U", SOLDER AREA:GOLD FLASH			
3	CNG013S230R-WW	Au 30U", SOLDER AREA:GOLD FLASH			
4	CNG031S220R-WW	Au 1U", SOLDER AREA:GOLD FLASH(单边刷金)	1.40	1.40	1.66
5	CNG031S300R-WW	Au 15U", SOLDER AREA:GOLD FLASH			
6	CNG031S230R-WW	Au 30U", SOLDER AREA:GOLD FLASH			

NO.	DESCRIPTION	MATERIAL	REMARKS	QTY
5	SHELL	STAINLESS STEEL	Ni Plated	1PCS
4	SPRING	STAINLESS STEEL	---	2PCS
3	SHIELDING PLATE	STAINLESS STEEL	Ni Plated	1PCS
2	CONTACT	COPPER ALLOY	Au/Ni Plated	1SET
1	HOUSING	HIGH TEMPERATURE PLASTIC	BLACK	1PCS

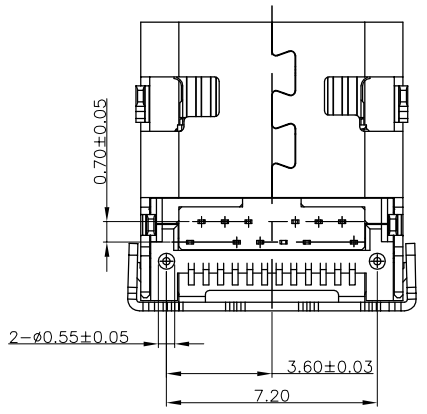

A1	GND	B12	GND	UNITS	SCALE	REV.	SHEET
A2	SSTXP1	B11	SSRXP1	mm	1:1	E	1 OF 1
A3	SSTXN1	B10	SSRXN1	 GENERAL TOLERANCE 0. ±0.35 0.0 ±0.30 0.00 ±0.25 0.° ±5° 0.0° ±3°	DATE	2019.01.03	
A4	VBUS	B9	VBUS		DR.	闵文	
A5	CC1	B8	SBU2		CHK.		
A6	DP1	B7	DN2		APPD.		
A7	DN1	B6	DP2				
A8	SBU1	B5	CC2				
A9	VBUS	B4	VBUS				
A10	SSRXN2	B3	SSTXN2				
A11	SSRXP2	B2	SSTXP2				
A12	GND	B1	GND				
PIN	SIGNAL NAME	PIN	SIGNAL NAME				

深圳市正耀科技有限公司  
 LITKCONN TECHNOLOGY CO., LTD.  
 TITLE: USB C TYPE 3.1 插板全PIN  
 SMT+DIP有缺口款

DATE: 2019.01.03  
 DR: 闵文  
 CHK: [Blank]  
 APPD: [Blank]

MAT'L: SEE TABLE  
 FINISH: SEE TABLE

DWG.NO: DWG-USB CF-017  
 PART NO: SEE TABLE  
 SIZE: A4

1

2

3

4

5

6