

Parameters Subject to Change Without Notice

FEATURES

- 4.7V to 40V operating input range
- 600mA output current
- Up to 93% efficiency
- High efficiency (>78%) at light load
- Internal Soft-Start
- 800kHz switching frequency
- Input under voltage lockout
- Available in SOT23-6 package
- Current run-away protection
- Short circuit protection
- Thermal protection

APPLICATIONS

- Distributed Power Systems
- Automotive Systems
- High Voltage Power Conversion
- Industrial Power Systems
- Battery Powered Systems

DESCRIPTION

The JW5018B is a current mode monolithic buck switching regulator. Operating with an input range of 4.7V~40V, the JW5018B delivers 600mA of continuous output current with two integrated N-Channel MOSFETs. The internal synchronous power switches provide high efficiency without the use of an external Schottky diode. At light loads, the regulator operates in low frequency to maintain high efficiency and low output ripple. Current mode control provides tight load transient response and cycle-by-cycle current limit.

The JW5018B guarantees robustness with short-circuit protection, thermal protection, current run-away protection, and input under voltage lockout.

ELECTRICAL SPECIFICATIONS

Parameter	Symbol	Value	Unit
Input Voltage	VIN	7.5~40	V
Output Voltage	VOUT	5	V
Output Current	IOUT	0~0.6	A

EVALUATION BOARD AND TYPICAL PERFORMANCE

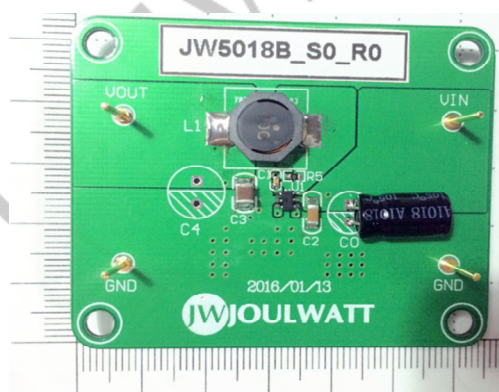

Efficiency vs Load Current
(Vout = 5V)

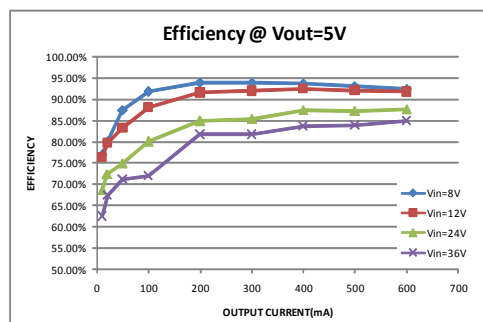

SCHEMATIC

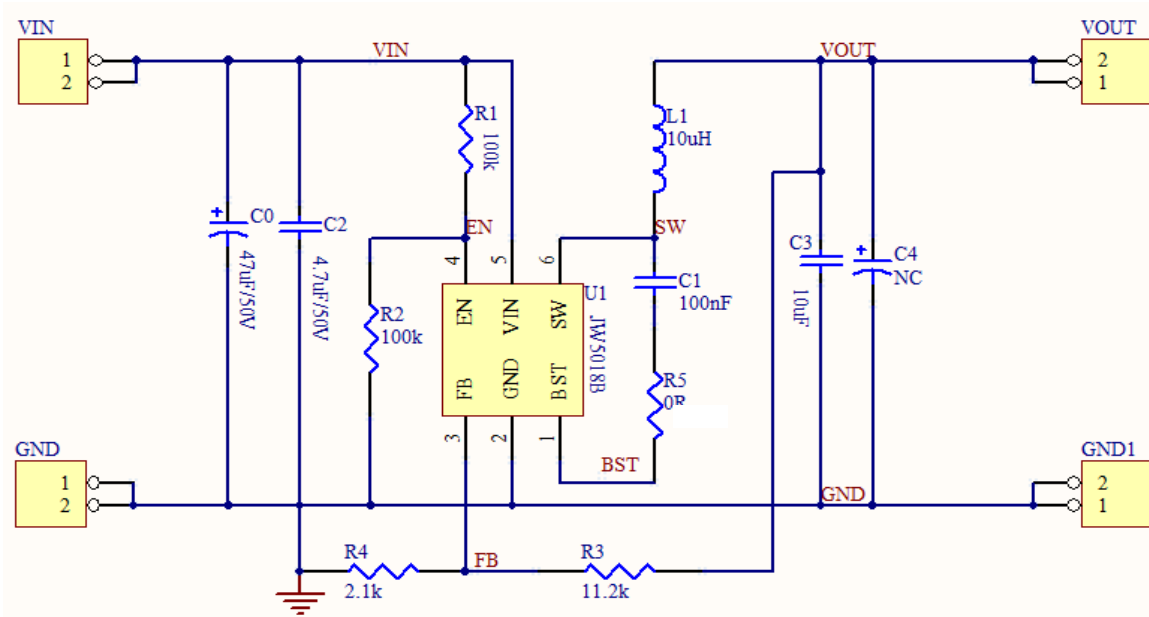

BILL OF MATERIALS

Qty.	Designator	Value	Description	Package	Manufacturer	Manufacturer P/N
1	C0	47uF	Electrolytic capacitor 50V	RB.1/.2		
1	C1	100nF	Ceramic capacitor 50V ,X7R	0603C	SAMSUNG	CL10B104KO8N NNC
1	C2	4.7uF	Ceramic capacitor 50V ,X7R	1206C	SAMSUNG	CL31B475KBHN NNE
1	C3	10uF	Ceramic capacitor 16V ,X7R	1210C		
0	C4	NC				
1	L1	10uH/3.2A	Inductor	7332	WE	
1	R1	100k	Resistor,5%	0603R	Uniohm	0603J0104T5E
1	R2	100k	Resistor,5%	0603R	Uniohm	0603J0104T5E
1	R3	11.2k	Resistor,1%	0603R	Uniohm	0603F1122T5E
1	R4	2.1k	Resistor,1%	0603R	Uniohm	0603F2101T5E
1	R5	0Ω	Resistor,5%	0603R	Uniohm	0603J0000T5E

Qty	Designator	Value	Description	Package	Manufacturer	Manufacturer P/N
1	VIN	7.5V~40V		TEST-Pole		
1	VOUT	5V/600mA		TEST-Pole		
1	JW5018B	40V/600mA	Buck	SOT23-6	Joulwatt	JW5018B

JoulWatt Confidential

PRINTED CIRCUIT BOARD LAYEROUT

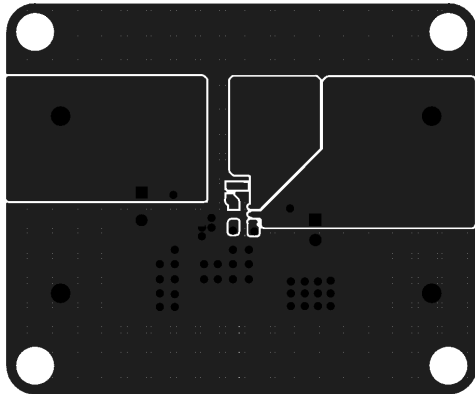

Figure1—Top Layer

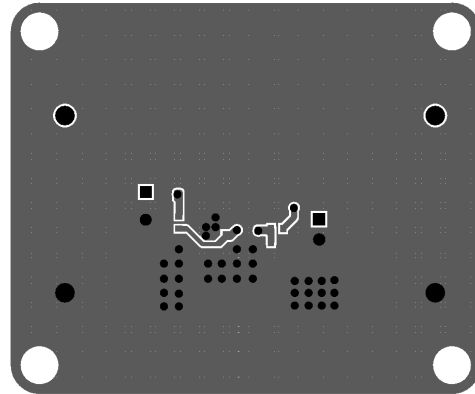

Figure2—Bottom Layer

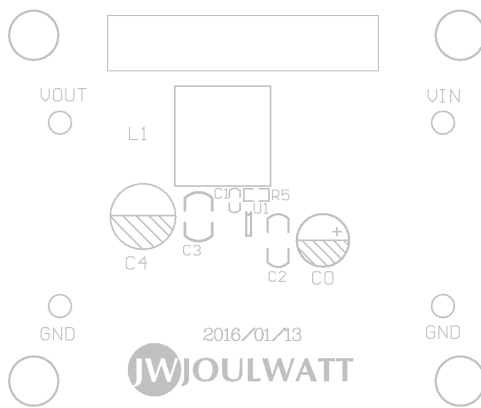

Figure3—Top Silk Layer



Figure4—Bottom Silk Layer

QUICK START GUIDE

1. Connect the positive terminal and negative terminal of the load to Vout and GND of EVB, respectively.
2. Connect a power supply between VIN and GND with the supply in “OFF” state. Set the output voltage of the power supply to 7.5V~40V.
3. Turn on the power supply and the evaluation board starts operating in normal condition.
4. The output voltage can be adjusted by varying the R3 and R4 on EVB.
For example: Fixed R4 to 2.1K, when adjusting the output voltage to 5V,
 $R3 = V_{out} / 0.8 * R4 - R4$.

For more information, please refer to the datasheet of JW5018B.

TYPICAL PERFORMANCE CHARACTERISTICS

Vin = 12V, Vout = 5V, L = 10μH, Cout = 10μF, TA = +25°C, unless otherwise noted

Steady State Test

VIN=12V, Vout=5V
Iout=600mA

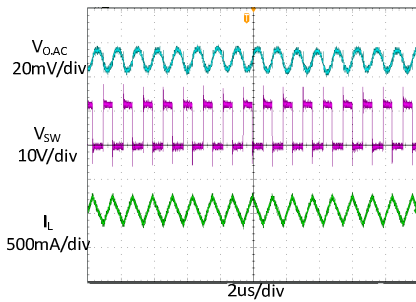

Startup through Enable

VIN=12V, Vout=5V
Iout=600mA(Resistive load)

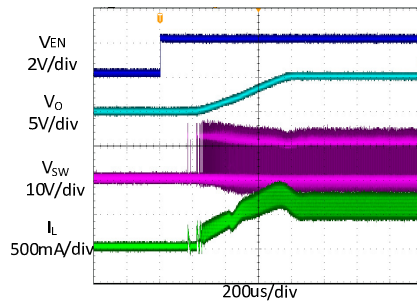

Shutdown through Enable

VIN=12V, Vout=5V
Iout=600mA(Resistive load)

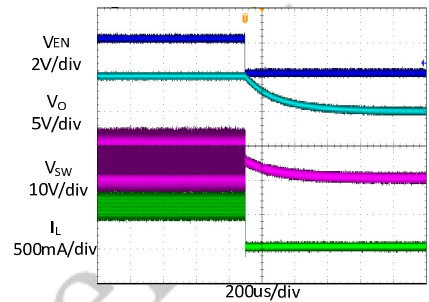

Light Load Operation

0 A LOAD

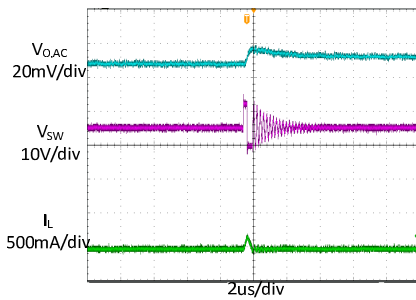

Medium Load Operation

300mA LOAD

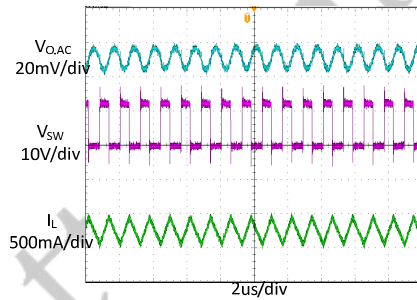

Heavy Load Operation

600mA LOAD

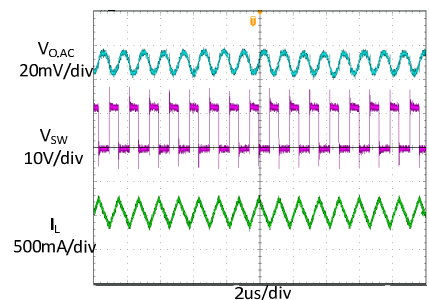

Short Circuit Protection

VIN=12V, Vout=5V
Iout=600mA- Short

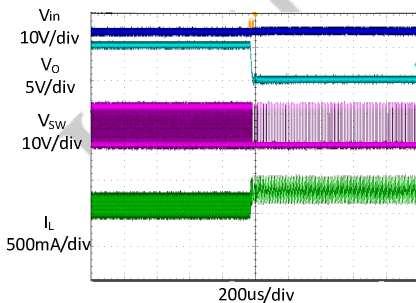

Short Circuit Recovery

VIN=12V, Vout=5V
Iout= Short-600mA

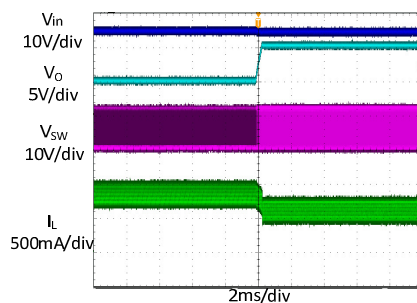

Load Transient

300mA LOAD → 600mA LOAD
→ 300mA LOAD

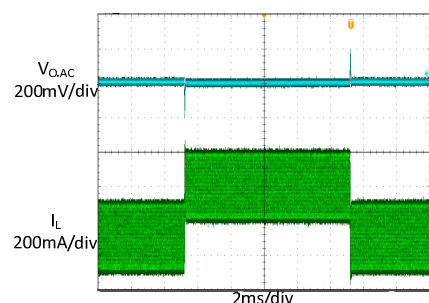

IMPORTANT NOTICE

- Joulwatt Technology Inc. reserves the right to make modifications, enhancements, improvements, corrections or other changes without further notice to this document and any product described herein.
- Any unauthorized redistribution or copy of this document for any purpose is strictly forbidden.
- Joulwatt Technology Inc. does not warrant or accept any liability whatsoever in respect of any products purchased through unauthorized sales channel.

JoulWatt Confidential

Copyright © 2015 EV5018B_S0_R0 Incorporated.

All rights are reserved by Joulwatt Technology Inc.