

皓宇(香港)有限公司 HAOYU (HONG KONG) LIMITED	文件編號	HY-WI-32
	發行日期	2008-07-23
SPECIFICATION 承認書	第 B-2 版	第 1 頁 共 3 頁

SERIES 產品系列	XLR 系列卡農插座		TYPE 產品型號	環保
DRAWN 設計	LIU FAZHAN		APVD 審批	ZHOU ZHIQUAN
1A. 額定負荷 RATED LOAD				
	DC 50V 3A			
SURFACE: AS SHOWN IN THE APPLICABLE DRAWING	CONSTRUCTION DIMENSION 結構尺寸		Apply to the appended drawing. 符合附加圖紙	
2 · OPERATING TEMPERATURE RANGE 操作溫度範圍	-20°C~70°C	PRESERVATIVE TEMPERATURE RANGE 儲存溫度範圍	20°C~70°C	
ITEM 項目	TEST CONDITIONS 測試條件			SPECIFICATIONS 規格
3 · ELECTRICAL PERFORMANCE (電氣性能規格):				
3A	CONTACT RESISTANCE 接觸電阻	TO BE MEASURED AT 1kHz AND 100m A MAX. WHEN THE MEASUREMENT SHALL BE MADE BY A MATING PLUG, OXIDATION FILM ON THE SURFACE MUST BE WIPED. RESISTANCE OF A PLUG CODE SHALL NOT BE INCLUDED AS A MEASUREMENT VALUE. 使用插頭插入即 1kHz 100mA 以下的微電流進行測定		50mΩ max 50 毫歐以下
3B	INSULATION RESISTANCE 絕緣阻抗	TO BE MEASURED BETWEEN ADJACENT TERMINALS AT 500V DC 導體之間在 DC500V 的狀態下		100MΩ min 100 兆歐以上.
3C	DIELECTRIC STRENGTH 耐電壓	A VOLTAGE OF AC 1500V SHALL BE APPLIED BETWEEN ADJACENT TERMINALS FOR 1 MIN. AT 50~60Hz 在導體相互之間外加 AC1500V 50~60Hz 1 分鐘		WITHOUT DAMAGE TO PARTS ARCING OR BREAKDOWN ETC 沒有損傷 變形絕緣破壞等異常.
4.MECHANICAL PERFORMANCE(機械性能規格)				
4A	INSERTION AND WITHDRAW FORCE 插拔力	THE FORCE WHEN A JACK SHALL BE INSERTED AND EXTRACTED SLOWLY AFTER FIXING A MATING PLUG AS SHOWN IN SECTION 1B TO THE PUSH-PULL SCALE. 使用標準插頭進行測定		Insertion and extraction force 4~40N 插拔力 4~40N 牛頓
4B	TERMINAL STRENGTH 端子強度	THE FORCE OF 4.9N SHALL BE APPLIED TO THE TERMINAL FOR 10 SEC(3 DIRECTION) 用 4.9N 的力在端子的三個方向上停留 10 秒		WITHOUT LOOSING AND BREAKDOWN. TERMINAL BEND SHALL BE ACCEPTED。 不應出現脫落，破損等但可以彎 曲
4C	STANDARD ATMOSPHEIC CONDITIONS 使用標準狀態	UNLESS OTHERWISE SPECIFIED. THE STANDRD RANGE OF ATMOSPHERIC CONDITIONS FOR MAKING MEASUREMENTS AND TESTS ARE AS FOLLOWS: AMDIENT TEMPERATURE: 15°C TO 35°C RELATIVE HUMIDITY :25%TO75%RH AIR PRESSURE :80Kpa TO 106Kpa		在沒有指定的情況下測試溫度濕 度、氣壓如下： (1) 溫度為 15°C~35°C (2) 濕度為 25%~75%RH (3) 氣壓 80Kpa ~106Kpa

皓宇(香港)有限公司 HAOYU (HONG KONG) LIMITED	文件編號	HY-WI-32
	發行日期	2008-07-23
SPECIFICATION 承認書	第 B-2 版	第 2 頁 共 3 頁

5 · DURABILITY (持久性)			
5A	RESISTANCE TO SOLDERING HEAT TEST 耐焊性試驗	THE TOP OF THE TERMINALS SHALL BEDIPPED 2mm . THE PLASTIC BODY IS 1.6mm ABOVE THE TIN LIGUID. 端子頂部被浸入焊錫池中 2mm 深, 膠身距離錫液 1.6mm。 Wave-soldering is to be performed within 3seconds at 260 +/-5 °C 波峰焊接溫度 260 +/-5°C 時間 3 秒。 Hand weilding to be performed within 3 seconds at 380°C or below. 手工焊接溫度為 380°C或以內, 時間為 3±0.5 秒。 注: 本產品只適合用手焊、波峰焊。	WITHOUT DEFORMATION OF CASE OREXCESSIVE LOOSENESS OF TERMINALSELECTRICAL CHARACTERISTICS SHALL BE SATISFIED. 本體無變形, 能滿足於機械、電氣性能。
5B	LIFE TEST. 壽命試驗	WITHOUT LOAD INSERTIONS AND EXTRACTIONS OF 5000 CYCLES SHALL BE MADE AT RATE OF 10 TO 20 CYCLES PER MINUTE 在負荷狀態下 10~20/分鐘, 來回插入及拔出至 5000 次	(1) CONTACT RESISTANCE SHALLBE 200mΩ max (2) MECHANICAL AND ELECTRICAL CHARACTERISTICS SHALL BESATISFIED。 (1) 接觸電阻不能超於 200mΩ (2) 其他滿足於機械電器性能。
5C	HEAT TEST. 耐熱試驗	85±2°C FOR 96 HOURS AFTER TEST KEEP IN NORMAL CONDITION FOR 1 HOUR. 在 85±2°C 環境中放 96 小時,再放在正常環境中 1 小時後進行 測試。	THERE SHALL BE NO DAMAGE ON APPEARANCE。 MECHANICAL AND ELECTRICAL CHARACTERISTICS SHALL BE SATISFIED 外觀無異常, 滿足於機械, 電器性能。
5D	HUMIDITY TEST. 耐濕試驗	40 ± 2 °C 90~96%RH FOR 96 HOURS, TEST AFTER KEEPING IN NORMAL CONDITION FOR 1 HOUR. 在 40±2°C 90~96%RH 環境中放 96 小時, 再放在正常環境 中, 1 小時後進行測試。	
5E	COLD TEST. 耐冷試驗	At -40±2°C for 96 HRS. AFTER TEST KEEP IN NORMAL CONDITION FOR 1 HOUR. 在-40±2°C 環境中放 96 小時,再置於正常環境中 1 小時後進行 測試。	
5F	SALT SPRAY TEST 噴霧試驗	AT 5% NAACL LIQUOR FOR 24HOURS, AFTER WASHING, KEEP IN NORMAL CONDITION FOR 30 MIN. 5%的 Nacl 溶液中噴霧 24 小時, 用水清洗並 在室溫下放置 30 分鐘	WITHOUT EXCESSIVE CORROSION OR CRACK IN APPEARANCE 表面無明顯腐蝕或鍍層脫落現象

皓宇(香港)有限公司 HAOYU (HONG KONG) LIMITED	文件編號	HY-WI-32
	發行日期	2008-07-23
SPECIFICATION 承認書	第 B-2 版	第 3 頁 共 3 頁

6 · 注意事項 (APPLICATION NOTES:)

1、在耐焊接過程中,不得把松香等絕緣、有腐蝕性物質浸入產品內。

(ROSIN AND OTHER INSULATING AND CAUSTIC MATERIAL CAN NOT BE DIPPED INTO THE ROCKET DURING SOLDERING.)

2、產品焊接後不能用氣槍吹或用溶劑沖洗。

(PRODUCTS CAN NOT BE BLOWN WITH AIR GUN OR CLEANED WITH A SOLVENT AFTER SOLDERING.)

3、產品焊接前各零件不能被溶化。

(ALL PARTS OF THE PRODUCTS CAN NOT BE DISSOLVED BEFORE SOLDERING.)

4、避免儲藏於高溫、潮濕及腐蝕的場所。

(AVOID STORING THE PRODUCTS IN A PLACE AT HIGH TEMPERATURE, HIGH HUMIDITY AND IN CORROSIVE GASES.)

5、貯存期限:自發貨之日起,貯存期不超過 180 天.若超出貯存期限,產生不良品,本公司概不負責。

(SHELF LIFE IS LESS THAN 180 DAYS SINCE THE GOODS WARE SENT OUT FROM OUR FACTORY. OUR COMPANY DOESN'T ACCEPT RESPONSIBILITY FOR REJECTS IF THE SHELF LIFE OF GOODS EXCEEDS 180 DAYS.)

6、本產品如有不良事件,望廠家及時回饋,以便及時記錄、查核、改善、跟蹤。

(PLEASE FEEL FREE TO REPORT TO US IF YOU DISCOVER THE INFERIOR GOODS, SO THAT WE CAN TAKE NOTE, CHECK, TRACK AND IMPROVE THEM. THANKS.)

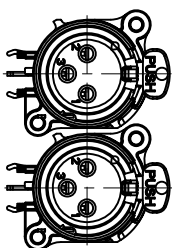
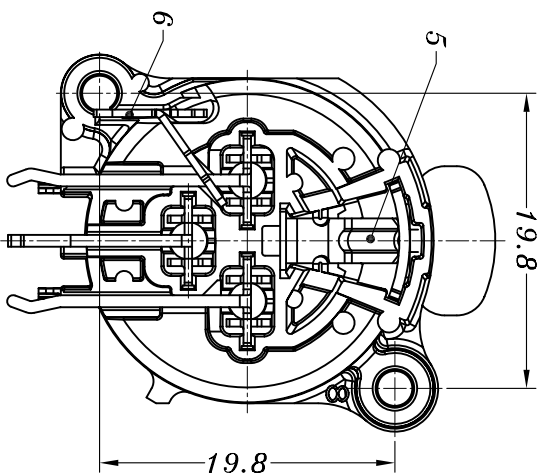
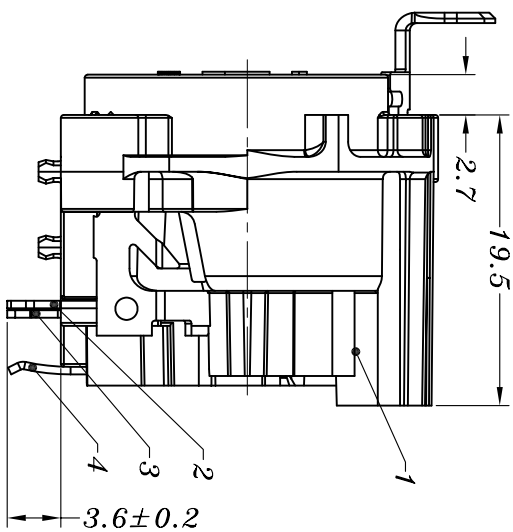
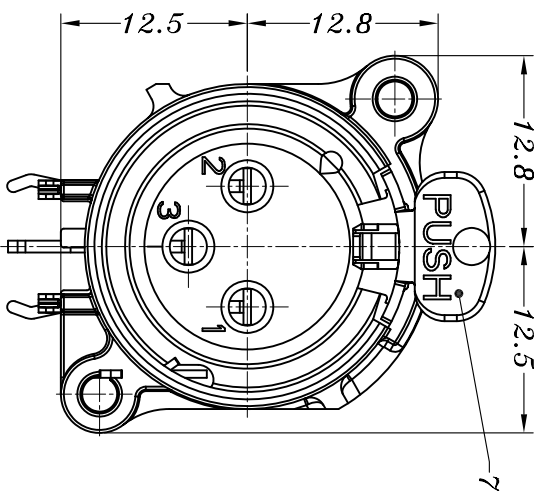

1:1

PANEL CUTOUT DETAIL

P.C.B LAYOUT

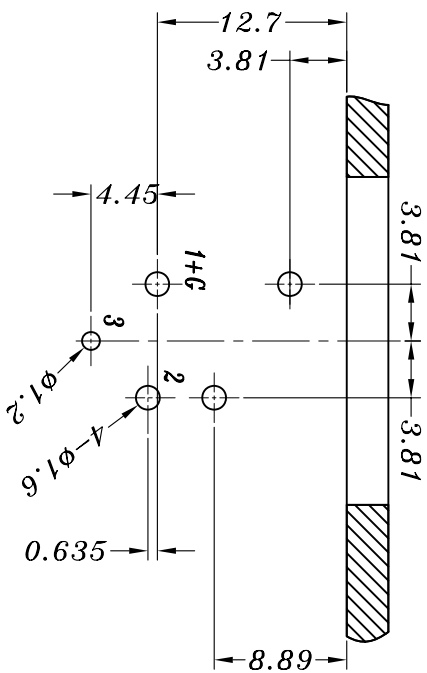
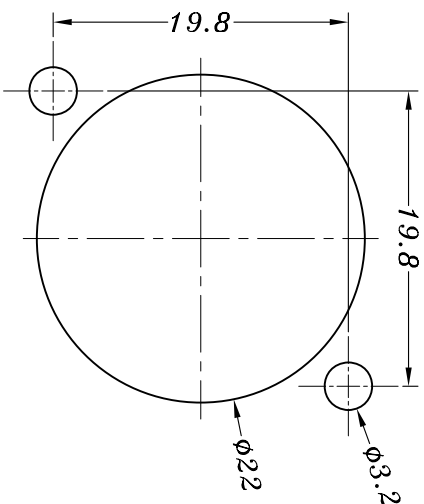

SCHEMATIC LAYOUT

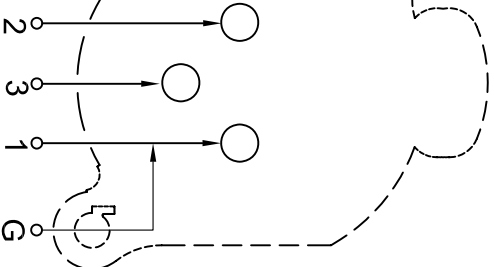

7	XLR-328P PUSH	SUS	1	Ni PLATED	TOLERANCE UNLESS SPECIFIED					
6	XLR-328-1 1+G CONTACT PIECES	PBS	1	Ni PLATED	UP TO 5mm: ±0.1	ANGULAR ±1°	1			
5	XLR-328P SPRING	MN	1	NaOH PROCESS	ABOVE 5mm: ±0.2					
4	XLR-328 3#CONTACT PIECES	PBS	1	Au PLATED	TITLE:XLR CONNECTOR					
3	XLR-328 2#CONTACT PIECES	PBS	1	Au PLATED	MODEL:XLR-328P-1		UNIT : MM	ROHS COMPLIANT	DWN	BY
2	XLR-328 1# CONTACT PIECES	PBS	1	Au PLATED			SCALE: 2:1	CHK'D	APPD	
1	XLR-328 CASE	PBT	1	BLACK						
NO.	PART NAME	MATERIAL	QTY	FINISHING	HAOYU(HONGKONG)LIMITED		PRO.AGL:			REV : A



HAOYU(HONGKONG)LIMITED
皓宇(香港)有限公司