

# SPECIFICATIONS FOR APPROVAL



Customer Part No.: \_\_\_\_\_ HELE. Part No: **X2C048000L71H-CEHZ**  
Application For: \_\_\_\_\_ Products: **CRYSTAL**  
Accepted Model: \_\_\_\_\_ Type & Freq.: **HSX211S / 48.000MHz**  
Sample Order No: **EOS-D60007-1** Date: **2013/06/03**

Approved By :

## 加高電子股份有限公司

**HARMONY ELECTRONICS CORP.**

**HARMONY ELECTRONICS (THAILAND) CO., LTD.**

**HARMONY ELECTRONICS (SHENZHEN) CORP., LTD.**

**HARMONY ELECTRONICS (SUZHOU) CO.,LTD**

**TAIPEI OFFICE:**

公司:(114)  
台北市內湖區堤頂大道 2 段 409  
號 2 樓  
2F., NO.409, SEC.2, TIDING  
BLVD., NEIHU DISTRICT,  
TAIPEI CITY 114, TAIWAN  
TEL:886-2-26588883  
FAX:886-2-26588683

**TAIWAN FACTORY:**

工廠:(831)  
高雄市大寮區大發工業區華東路  
39 號  
No.39, HWA DONG RD.,  
DALLIAO DIST.,DAFA  
INDUSTRIAL PARK.,  
KAOHSIUNG CITY 831,  
TAIWAN  
TEL: (07)787-1555-6  
FAX: (07)787-1557

**THAILAND FACTORY:**

66MOO 5,  
KAONGU-BEOKPRAI RD.,  
T.BEOKPRAI, A. BANPONG,  
RAJCHABUREE PROVINCE  
70110, THAILAND  
TEL: (032)221994-6,  
200740-1  
FAX: (032)200742

**SHENZHEN FACTORY:**

深圳市福永鎮塘尾村塘橋路聚源  
工業區  
QIAO TANG RD., TANGWEI  
VILLAGE FU YONG TOWN  
SHENZHEN CITY CHINA  
TEL: 0755-27309272 /  
27309262  
FAX: 0755-27309755

**SUZHOU FACTORY:**

蘇州市相城區黃埭鎮安民路 5 號  
NO.5 ANMING ROAD,  
HUANGDAI TOWN,  
XIANGCHENG DISTRICT,  
SUZHOU CITY, JIANGSU  
PROVINCE  
TEL:86-512-67592373  
FAX:86-512-67592363

Title <b>HSX211S</b> <b>QUARTZ CRYSTAL SPECIFICATION</b>				Country of origin <b>TAIWAN FACTORY</b> <b>THAILAND FACTORY</b> <b>CHINA FACTORY</b>		
Date	Confirm	Check	Prepare	Spec. No.	Rev.	Page
<b>2013/06/03</b>	F. S. TSAI	Y. W. LEE	U. F. CHEN	<b>X2C048000L71H-CEHZ</b>	0	1

**HARMONY ELECTRONICS CORP.**

# HSX211S SPECIFICATION

## INDEX

ITEM	PAGE
1. QUARTZ CRYSTAL UNIT SPECIFICATION . . . . .	3
2. MARKING & DIMENSIONS . . . . .	4
3. INSIDE STRUCTURE . . . . .	5
4. EMBOSS CARRIER TAPE&REEL . . . . .	
a. DIMENSIONS OF CARRIER TAPE . . . . .	6
b. DIMENSIONS OF REEL . . . . .	6-7
c. STORAGE CONDITION . . . . .	7
d. STANDARD PACKING QUANTITY . . . . .	7
e. MATERIAL OF TAPE . . . . .	7
f. LABEL CONTENTS . . . . .	7
g. TAPING DIMENSION . . . . .	8
h. JOINT OF TAPE . . . . .	8
i. RELEASE STRENGHT OF COVER TAPE . . . . .	8
j. PACKAGE . . . . .	9
5. MECHANICAL ENDURANCE . . . . .	10
6. ENVIRONMENTAL ENDURANCE . . . . .	11
7. SUPPLEMENT . . . . .	12-13
8. Flow Chart . . . . .	14

Title HSX211S QUARTZ CRYSTAL SPECIFICATION				Country of origin <b>TAIWAN FACTORY</b> <b>THAILAND FACTORY</b> <b>CHINA FACTORY</b>		
Date	Confirm	Check	Prepare	Spec. No.	Rev.	Page
<b>2013/06/03</b>	F. S. TSAI	Y. W. LEE	U. F. CHEN	<b>X2C048000L71H-CEHZ</b>	0	2

# 1. QUARTZ CRYSTAL UNIT SPECIFICATION

- 1. Frequency: 48.000000MHz
- 2. Holder type : **HSX211S**
- 3. Frequency tolerance: +/-8ppm at 25deg.C +/-3deg.C
- 4. Equivalent resistance: 22 ohms Max. / SERIES
- 5. Storage temperature range: -40 deg.C To +125 deg.C
- 6. Operable temperature range: -30 deg.C To +85 deg.C
- 7. Temperature drift: +/-12 ppm -30 deg.C To +85 deg.C
- 8. Loading capacitance (CL) : 7.8 pF
- 9. Drive level: 10μW (100uW Max)
- 10. Shunt Capacitance: 0.64~1.04 pF
- 11. Insulation resistance : More than 500M ohms at DC 100V
- 12. Mode of oscillation: Fundamental
- 13. Circuit: Measured in HP/E5100A,S&A 250B
- 14. Shocking : Dropping from 75 cm height 3 times on firm wood  
 Variation : Frequency less than +/-5 ppm  
 Resistance less than +/- 15 % or 2ohms max.
- 15. Aging: Less than +/- 3 ppm/Year
- 16. Holder HSX211S Seam type
- 17. Dimensions and marking Refer to page.4
- 18. Emboss carrier tape & reel Refer to page.6 and page.7
- 19. Moisture Sensitivity Level Level 1
- 20. Note : Spurious: 1100ohm (+/- 700KHz)  
 C1: 2.16~4.16 fF  
 L1: 1.0~4.0 mH

Title <b>HSX211S</b> QUARTZ CRYSTAL SPECIFICATION				Country of origin <b>TAIWAN FACTORY</b> <b>THAILAND FACTORY</b> <b>CHINA FACTORY</b>		
Date	Confirm	Check	Prepare	Spec. No.	Rev.	Page
<b>2013/06/03</b>	F. S. TSAI	Y. W. LEE	U. F. CHEN	<b>X2C048000L71H-CEHZ</b>	0	3

## 2. HSX211S MARKING & DIMENSIONS

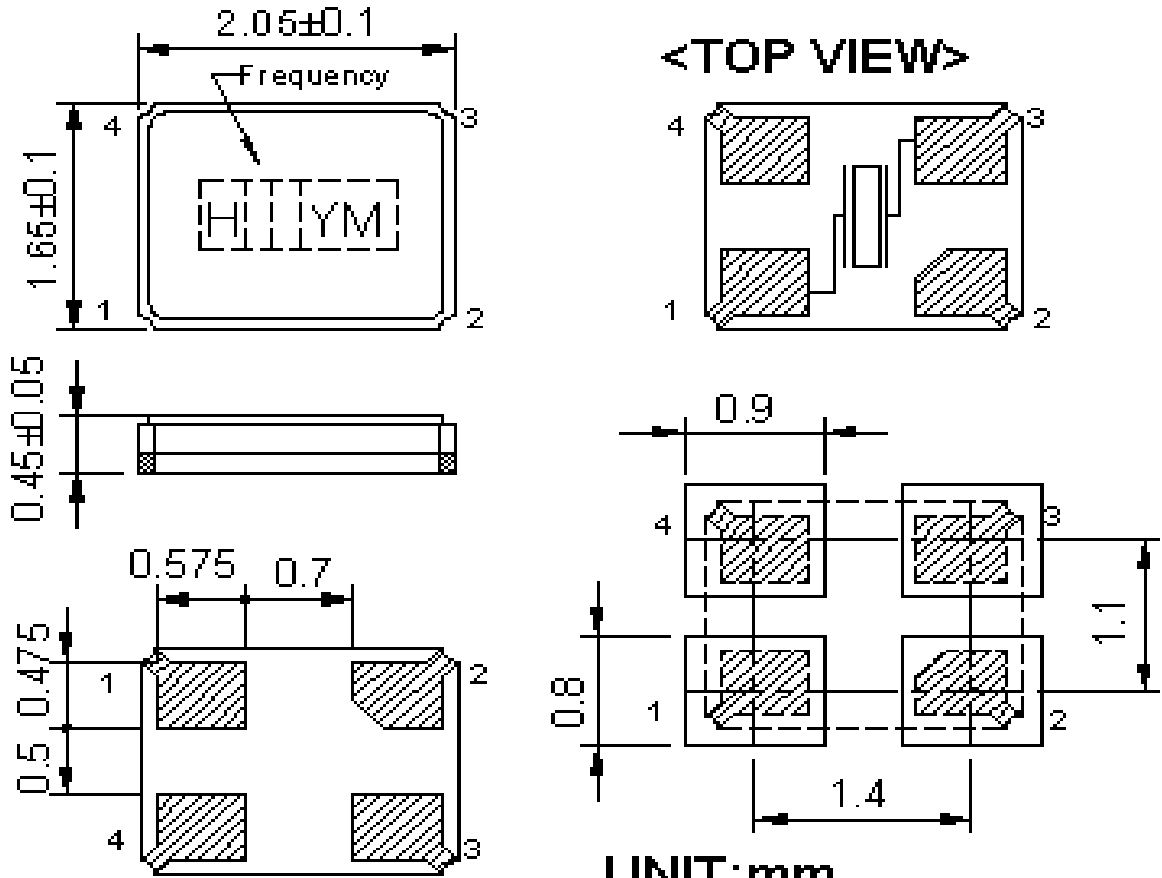

UNIT:mm

TOLERANCE:±0.1

Chamfer index mark depends on the ceramic base supplier.

\*Marking should be printed as following:

Logo, Nominal Frequency, Manufactured year & month

\*Nominal frequency = integer only

( ex. 14.31818 MHz → 14 )

\*Manufacturing Lot No.

(Y: year) ex. 2000 shall be marked as ' 0 ' (As shown on the Table-1)

(M: month) ex. June shall be marked as ' F ' (As shown on the Table-2).

Marking : Laser marking.

(Table-1)

Year	2000	2001	2002	2003	2004	2005	2006	2007	2008	2009
	2010	2011	2012	2013	2014	2015	2016	2017	2018	2019
Code	0	1	2	3	4	5	6	7	8	9

(Table-2)

Jan.	Feb.	Mar.	Apr.	May.	Jun.	Jul.	Aug.	Sep.	Oct.	Nov.	Dec.
A	B	C	D	E	F	G	H	J	K	L	M

Title HSX211S QUARTZ CRYSTAL SPECIFICATION				Country of origin <b>TAIWAN FACTORY</b> <b>THAILAND FACTORY</b> <b>CHINA FACTORY</b>			
Date	Confirm	Check	Prepare	Spec. No.	Rev.	Page	
2013/06/03	F. S. TSAI	Y. W. LEE	U. F. CHEN	X2C048000L71H-CEHZ	0	4	

HARMONY ELECTRONICS CORP.

### 3. INSIDE STRUCTURE

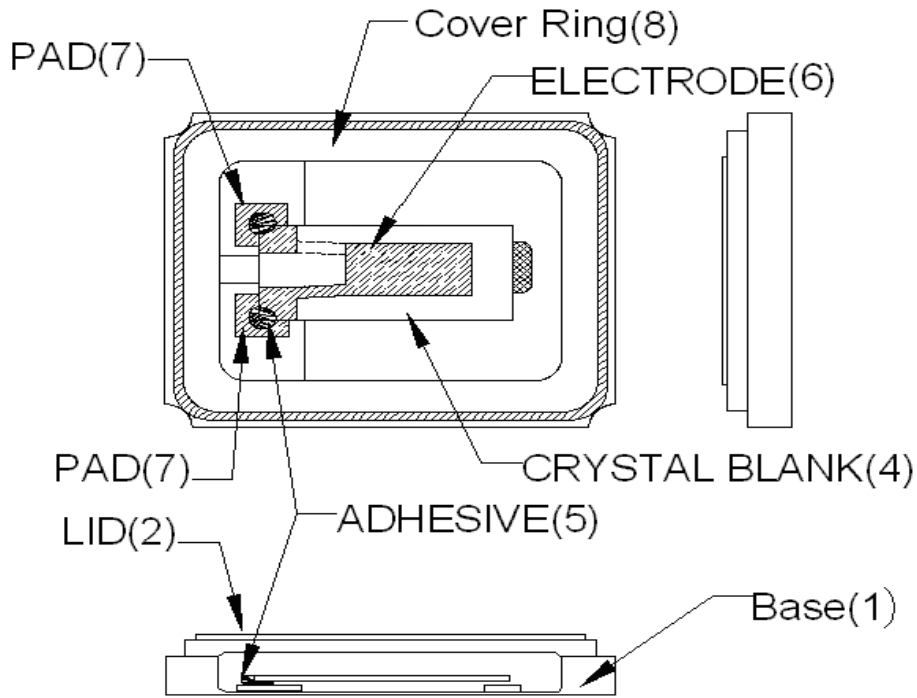

※Reference drawing

(1) Base: Alumina Ceramic ( $Al_2O_3$ ) Metallized Pad: Mo Ni Plating Au Plating
(2) LID: Fe- Ni -Co
(3) Crystal Enclosure Seal: Seal Seam
(4) Crystal Blank Rectangular At-Cut Quartz Crystal Blank
(5) Adhesive Silver Conductive Silicon Resin
(6) Electrode
(7) PAD Alumina Ceramic : Mo Ni Plating Au Plating
(8) Cover Ring : Fe-Ni-Co Alloy

The use prohibition chemistry substance of Table 1 of DHE-0204-1 (HE-QA-24) is not included in this item.

Title HSX211S QUARTZ CRYSTAL SPECIFICATION				Country of origin <b>TAIWAN FACTORY</b> <b>THAILAND FACTORY</b> <b>CHINA FACTORY</b>		
Date <b>2013/06/03</b>	Confirm F. S. TSAI	Check Y. W. LEE	Prepare U. F. CHEN	Spec. No. <b>X2C048000L71H-CEHZ</b>	Rev. 0	Page 5

#### 4. HSX211S EMBOSS CARRIER TAPE & REEL

##### a.) Dimensions of Carrier Tape

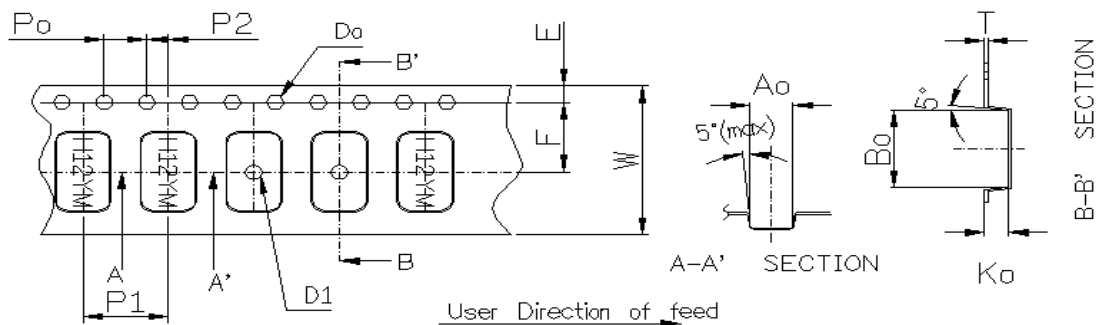

Symbol	<b>A<sub>0</sub></b>	<b>B<sub>0</sub></b>	<b>K<sub>0</sub></b>	<b>P<sub>0</sub></b>	<b>P<sub>1</sub></b>	<b>P<sub>2</sub></b>
Spec	1.9±0.10	2.3±0.10	0.65±0.10	4.0±0.1	4.0±0.1	2.0±0.05
Symbol	<b>E</b>	<b>F</b>	<b>D<sub>0</sub></b>	<b>D<sub>1</sub></b>	<b>W</b>	<b>T</b>
Spec	1.75±0.1	3.5±0.05	∅1.55±0.05	∅1.1±0.05	8.0±0.2	0.25±0.02

##### b.) Dimensions of Reel

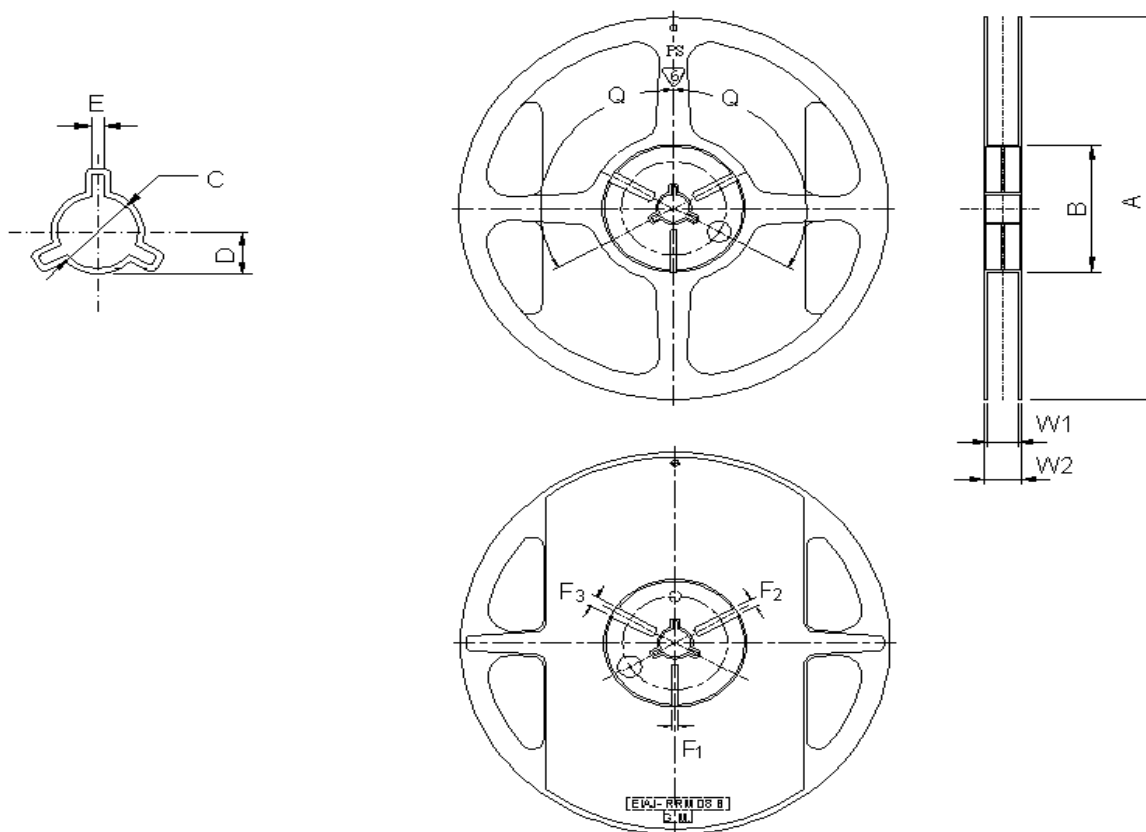

Title HSX211S

QUARTZ CRYSTAL SPECIFICATION

Country of origin

**TAIWAN FACTORY**  
**THAILAND FACTORY**  
**CHINA FACTORY**

Date

Confirm

Check

Prepare

Spec. No.

Rev.

Page

2013/06/03

F. S. TSAI

Y. W. LEE

U. F. CHEN

**X2C048000L71H-CEHZ**

0

6

(Table-2)

(UNIT: mm)

ITEM		MARK	DIMENSIONS · ANGLE	
FLANCE	Diameter	A	$\phi$ 180+0/-3	
	Inner Width	W1	9.3+/-0.3	
	Outer Width	W2	11.3+/-1.0	
HUB	Out Line diameter	B	$\phi$ 60.5+/-0.5	
	Center Core slit	Width	F1	3.0+0.5/-0
			F2	4.0+0.5/-0
			F3	5.0+0.5/-0
		Position	q	120deg
	Spindle diameter		C	$\phi$ 13.2+/-0.5
Key Ditch	Width	E	3.0+/-0.2	

## c.) Storage condition

Temperature: +40deg.C Max.

Relative Humidity: 80% Max.



## d.) Standard packing quantity

3,000PCS / REEL

## e.) Material of the tape

Tape	Material
Carrier tape	PS Conductive
Top tape	Polyester

## f.) Label contents

	
TYPE:	
SPEC.No.:	
Parts No.:	
LotNo.:	
FREQ.:	MHz
Q'TY:	PCS
HARMONY ELECTRONICS CORP.  HSF	

Sticks label for every reel.

Title HSX211S QUARTZ CRYSTAL SPECIFICATION				Country of origin <b>TAIWAN FACTORY</b> <b>THAILAND FACTORY</b> <b>CHINA FACTORY</b>		
Date	Confirm	Check	Prepare	Spec. No.	Rev.	Page
2013/06/03	F. S. TSAI	Y. W. LEE	U. F. CHEN	<b>X2C048000L71H-CEHZ</b>	0	7

HARMONY ELECTRONICS CORP.

g.) Taping dimension

Leader	Cover-tape	The length of cover-tape in the leader is more than 400 mm including empty embossed area.
	Carrier-tape	After all products were packaged, must remain more than twenty pieces or 400 mm empty area, which should be sealed by cover-tape.
Terminal	Cover-tape	The tip of cover-tape shall be fixed temporary by paper tape and roll around the core of reel one round.
	Carrier-tape	The empty embossed area which are sealed by top cover-tape must remain more the 40 mm.

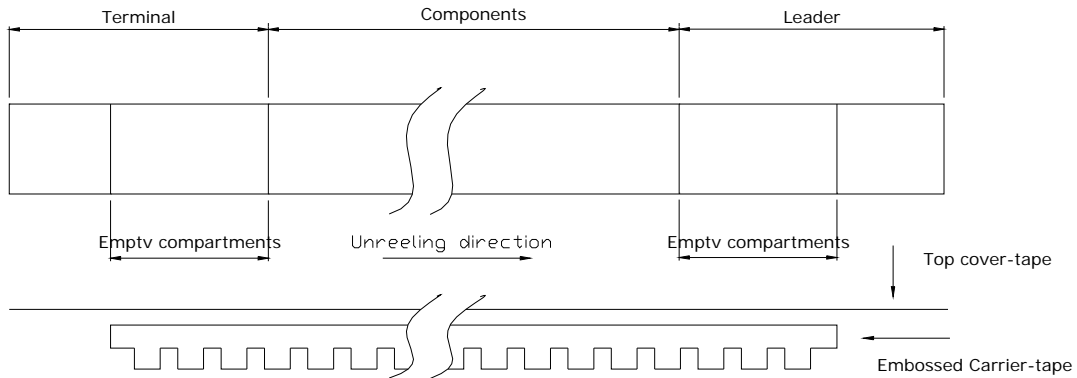

h.) Joint of tape

The carrier-tape and top cover-tape should not be jointed.

i.) Release strength of cover tape

It has to between 0.1N to 0.7N under following condition.

Pulling direction 165° to 180°

Speed 300mm/min.

Otherwise unless specified.

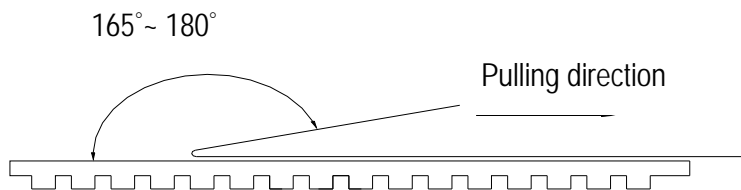

Other standards shall be based on JIS C 0806-1990.

Title HSX211S QUARTZ CRYSTAL SPECIFICATION				Country of origin <b>TAIWAN FACTORY</b> <b>THAILAND FACTORY</b> <b>CHINA FACTORY</b>		
Date	Confirm	Check	Prepare	Spec. No.	Rev.	Page
2013/06/03	F. S. TSAI	Y. W. LEE	U. F. CHEN	X2C048000L71H-CEHZ	0	8



j.) Package

1. Reel :  $\varnothing 180$

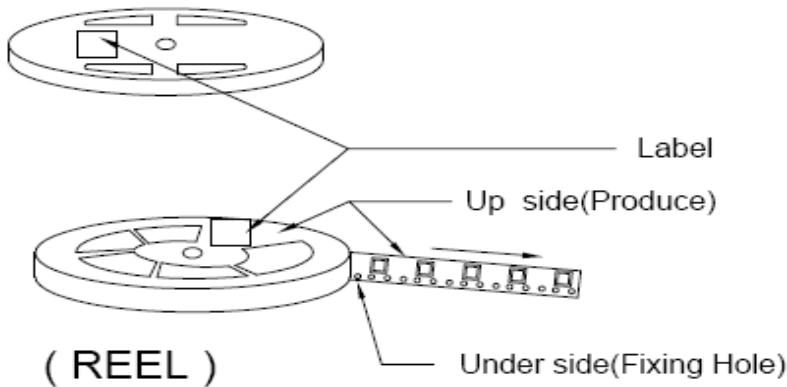

( REEL )

## 2. Carton

One reel quantity: [ 1000pcs ] & [ 3000pcs ]

- ① Top and bottom with 2.3cm thickness foam-rubber cushion for protection.
- ② Carton's Q'TY: 1~15 pcs.
- ③ Carton Type=A,B,C use 4 trigon pillar to fasten the Reel.
- ④ Need to add 3 pages dry agent in each outer box.

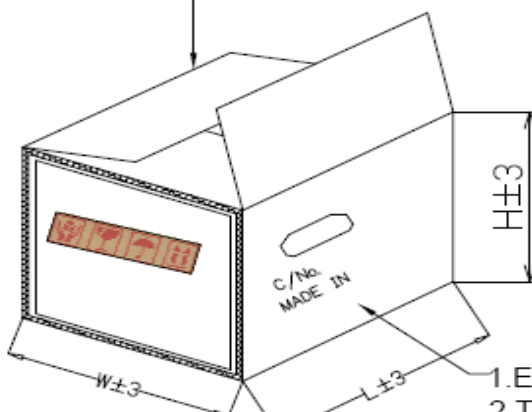
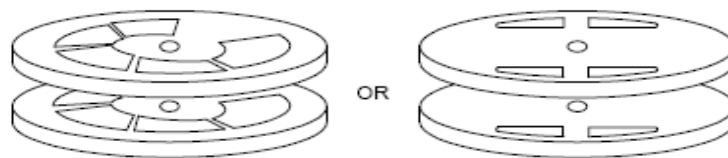
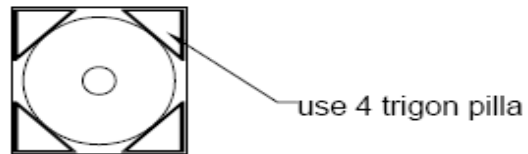

Carton Type	A	B	C	D
Produce Type	840/751	630/531/ 421	321/21	OTHER
Reel	15	15	15	1~7
L±3	200	200	200	195
W±3	200	200	200	195
H±3	230	230	230	150

( Carton )

1. Every Carton with 3 desiccant.
2. Top and bottom with 2.3cm thickness foam-rubber cushion for protection

Title HSX211S QUARTZ CRYSTAL SPECIFICATION				Country of origin <b>TAIWAN FACTORY</b> <b>THAILAND FACTORY</b> <b>CHINA FACTORY</b>		
Date <b>2013/06/03</b>	Confirm F. S. TSAI	Check Y. W. LEE	Prepare U. F. CHEN	Spec. No. <b>X2C048000L71H-CEHZ</b>	Rev. 0	Page 9

## 5. Mechanical Performance

Item		Test Methods	Specifications Code
1	Natural Drop	Drop 3 times from the height of 75cm onto min. 30mm thickness hard wooden board.	A
2	Vibration	Frequency 10-55Hz, Sine Wave full amplitude of 0.8mm to X, Y and Z 3 axes, Duration of 2 hours to each axis.	A
3	Sealing Tightness	Leak Rate $1.0 \times 10^{-8}$ Pa-m <sup>3</sup> /sec. Max. Measured by Helium leak detector.	---
4	Solderability	After applying ROSIN Flux, dipping in solder bath at 245deg.C +/- 5deg.C for 3 +/- 0.5 sec.	B
5	Substrate Bending	Mount a sample on board. Apply Pressure to the center of board until it is bent to 3 mm and hold for $5 \pm 1$ sec Pressure speed : 0.5 mm / sec	A
6	Adhesion	Mount a sample on the circuit board. Apply pressure vertically to the side of specimen attached to the circuit board with the pressure jig. Pressure : 5N for $10 \pm 1$ sec	A
7	Body strength	Apply pressure to the center of body with the R0.5 pressure jig. pressure : 10N for $10 \pm 1$ sec	A

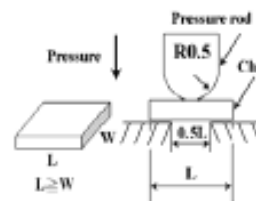
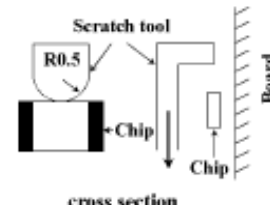
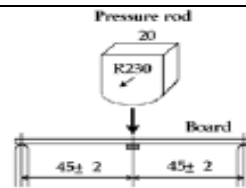

Title HSX211S QUARTZ CRYSTAL SPECIFICATION				Country of origin <b>TAIWAN FACTORY</b> <b>THAILAND FACTORY</b> <b>CHINA FACTORY</b>		
Date	Confirm	Check	Prepare	Spec. No.	Rev.	Page
2013/06/03	F. S. TSAI	Y. W. LEE	U. F. CHEN	X2C048000L71H-CEHZ	0	10

## 6. Environment Performance

Item		Test Methods	Specifications Code
1	Humidity	Temperature 60°C +/-2°C, RH 90~95%, Duration of 240 hours. Back to room temperature first, then in 1~2 hours, the component shall be checked.	A
2	Storage in Low Temperature	-40deg.C +/-2deg.C, Duration of 240 hours. Back to the room temperature first, then in 1~2 hours, the component shall be checked.	A
3	Storage in High Temperature	+85deg.C +/-2deg.C, Duration of 240 hours. Back to the room temperature first, then in 1~2 hours, the component shall be checked.	A
4	Temperature cycles	-40deg.C +/-2deg.C (30min) ↔ +85deg.C +/-2deg.C (30min) 25 cycles. Back to the room temperature first, then in 1~2 hours, the component shall be checked.	A

Specifications code	Specifications
A	Frequency variation shall be within +/-5ppm and equivalent resistance shall be within +/-15% or $2\Omega$
B	More than 90% of lead shall be covered by new solder.

Title HSX211S QUARTZ CRYSTAL SPECIFICATION				Country of origin <b>TAIWAN FACTORY</b> <b>THAILAND FACTORY</b> <b>CHINA FACTORY</b>		
Date	Confirm	Check	Prepare	Spec. No.	Rev.	Page
2013/06/03	F. S. TSAI	Y. W. LEE	U. F. CHEN	<b>X2C048000L71H-CEHZ</b>	0	11

## 7. Supplement

### 7.1.Soldering

7.2.Please stay with our proposed reflow condition and do then soldering 2 times max.

**Available for Lead Free Soldering**

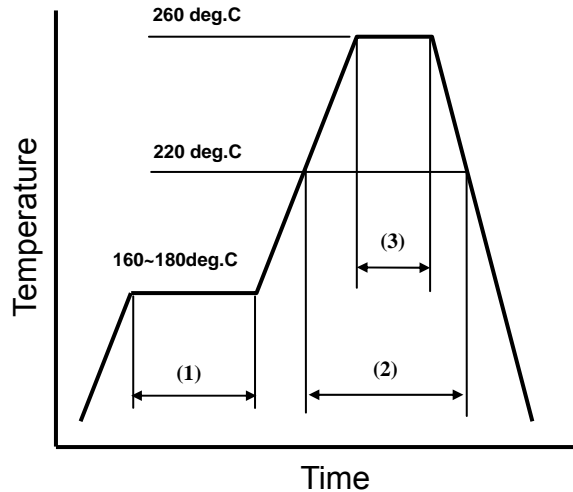

(1)	Preheat	160~180 deg.C	120sec.
(2)	Primary heat	220 deg.C	60sec.
(3)	Peak	260 deg.C	10sec. Max.

### 7.3.Land pattern layout(Example)

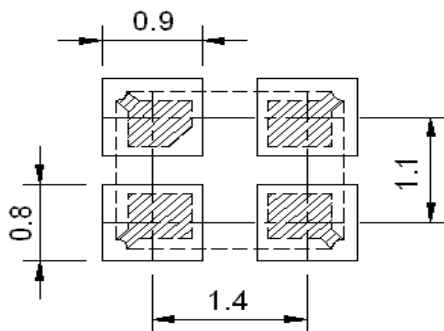

### 7.4.Solder iron (Example)

Bit temp.:350°C max.,Time:3sec max. ,Each terminal solder a 1 time max.

Title HSX211S QUARTZ CRYSTAL SPECIFICATION				Country of origin <b>TAIWAN FACTORY</b> <b>THAILAND FACTORY</b> <b>CHINA FACTORY</b>		
Date	Confirm	Check	Prepare	Spec. No.	Rev.	Page
2013/06/03	F. S. TSAI	Y. W. LEE	U. F. CHEN	X2C048000L71H-CEHZ	0	12

### 7.5.Mounting

This component is designed for automatic insertion.

However, you are requested to do the trial with your insertion machine in order to be sure of proper operation and no damage of component.

Please pay attention to board warp which may damage the component and cause Soldering Process.

### 7.6.Cleaning

Cleaning liquid which corrodes Nickel shall not be used

It may cause the problem on the surface, color, marking etc.

Ultra-sonic cleaning is possible, however, you are requested to check on your board.

Because we only checked as single unit.

### 7.7.Storage

Please keep away from high temperature and high humidity ,which may cause put solderbility. No direct Sunlight, No dew as well.

Title <b>HSX211S</b> <b>QUARTZ CRYSTAL SPECIFICATION</b>				Country of origin <b>TAIWAN FACTORY</b> <b>THAILAND FACTORY</b> <b>CHINA FACTORY</b>		
Date	Confirm	Check	Prepare	Spec. No.	Rev.	Page
<b>2013/06/03</b>	F. S. TSAI	Y. W. LEE	U. F. CHEN	<b>X2C048000L71H-CEHZ</b>	0	13

### 8. Flow Chart

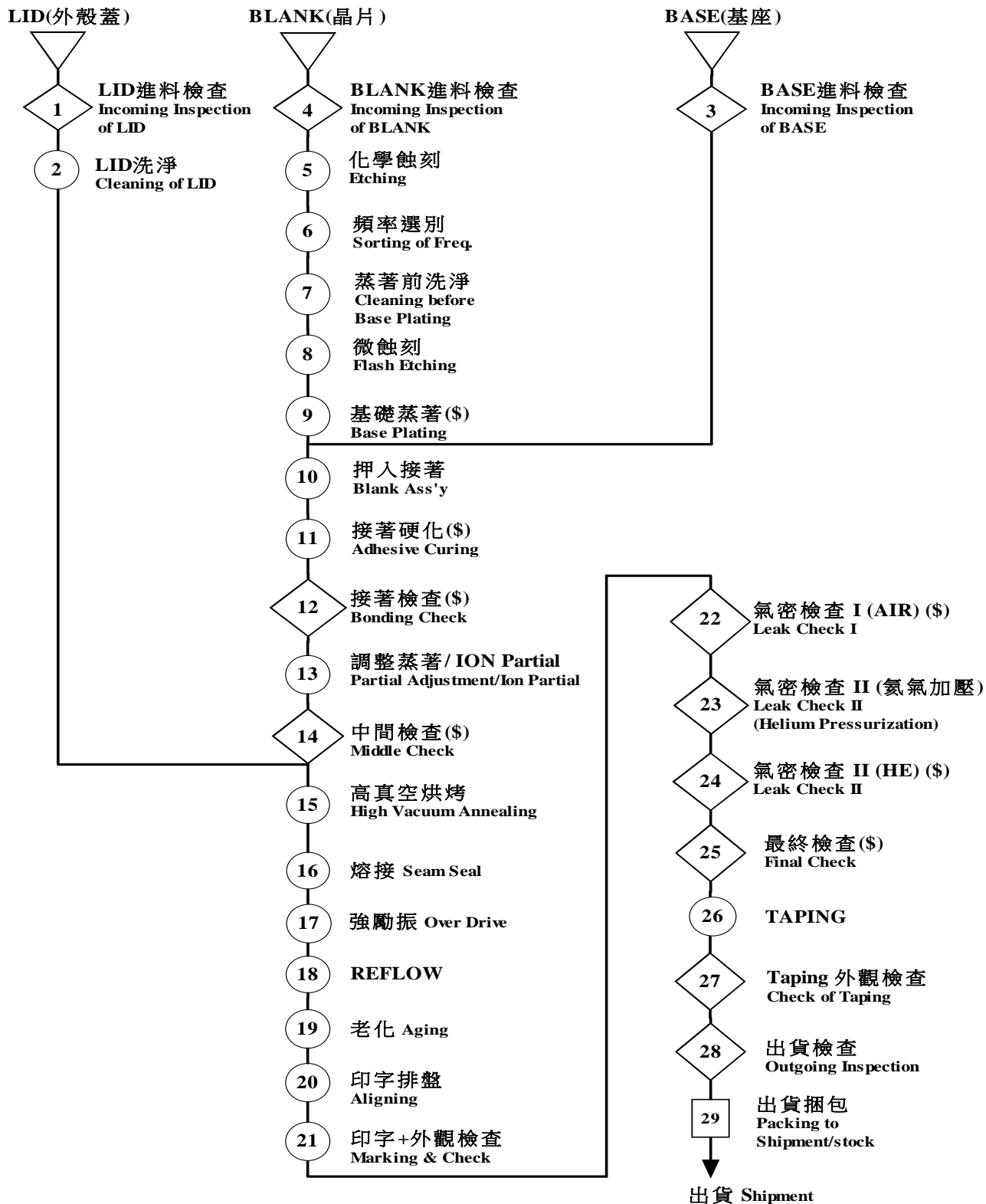

(\$) : 特殊特性  
(For Special Characteristics)

Title HSX211S QUARTZ CRYSTAL SPECIFICATION				Country of origin <b>TAIWAN FACTORY</b> <b>THAILAND FACTORY</b> <b>CHINA FACTORY</b>		
Date	Confirm	Check	Prepare	Spec. No.	Rev.	Page
2013/06/03	F. S. TSAI	Y. W. LEE	U. F. CHEN	X2C048000L71H-CEHZ	0	14

REV. No.	DATE	REASON	CONTENTS
0	2013/06/03	New	

Title HSX211S QUARTZ CRYSTAL SPECIFICATION				Country of origin <b>TAIWAN FACTORY</b> <b>THAILAND FACTORY</b> <b>CHINA FACTORY</b>		
Date	Confirm	Check	Prepare	Spec. No.	Rev.	Page
<b>2013/06/03</b>	F. S. TSAI	Y. W. LEE	U. F. CHEN	<b>X2C048000L71H-CEHZ</b>	0	15

HARMONY ELECTRONICS CORP.